



# CROSSFIRE E5

## USER MANUAL



**WARNING:**

Read this Manual,  
and any  
Supplements  
Carefully  
Before Operating  
Vehicle.

- Assembly
- Operation
- Maintenance

**THIS VEHICLE IS  
NOT DESIGNED  
FOR USE ON  
RENTAL TRACKS  
OR RACING**

***OWNER'S/OPERATOR'S  
MANUAL***

1.0



**LH50DU**

(Independent Rear Suspension)

**BEFORE OPERATING THIS VEHICLE, THE OWNER AND EACH OPERATOR  
MUST HAVE READ AND HAVE AN UNDERSTANDING OF ALL THE  
INSTRUCTIONS FOR PROPER ASSEMBLY AND SAFE OPERATION, AS  
WELL AS THE INSTRUCTIONS CONCERNING THE BATTERIES AND ALL  
OTHER PORTIONS OF THE VEHICLE.**

**NOTE:** A storage area/toolbox has been provided on the CUV for storage of this manual, and addendums.

Please keep this manual and addendums in the glove compartment so that it can be found easily and referenced when needed.

---

# CONTENTS

1. INTRODUCTION .....	1.1
2. UNDERSTANDING WARNINGS .....	2.1
3. SAFETY WARNING .....	3.1
4. DAILY PRE-RIDE INSPECTION .....	4.1
5. OPERATION WARNING .....	5.1
6. VIN .....	6.1
7. CONTROL AND PARTS FUNCTIONS .....	7.1
8. RIDING GEAR .....	8.1
9. CARRYING LOAD .....	9.1
10. DRIVING YOUR VEHICLE .....	10.1
11. BATTERY .....	11.1
12. MAINTENANCE .....	12.1
13. TOOL .....	13.1
14. SPECIFICATION .....	14.1
15. WIRING DIAGRAM .....	15.1

# OWNER'S/OPERATOR'S MANUAL 1.0

LH50DU 使用维修说明书（用户手册） 英文 版本 1.0

# 1. INTRODUCTION

---

## Introduction

Congratulations on the purchase of your Cargo Utility Vehicle (CUV). We take pride in offering you this product engineered and manufactured to the highest performance and quality standards. We are sure that you will enjoy superior levels of performance, reliability, riding comfort, and safety.

This manual is provided to help the owner and operators of this CUV become familiar with the operating characteristic, and the many features offered on the CUV. The manual also covers information on the care and maintenance of your CUV.

Please read this manual carefully. The information contained in this Owner's Manual, the Warning Labels supplied with this product will help you to understand the safe use and maintenance of your CUV. Make sure that you understand and follow all Warnings and Instructions in this material.

If you did not receive any of the material listed above, please call your dealer and request to have them sent to you.

This is a utility vehicle. Never operate on public roads. This vehicle does not meet National Highway Traffic Safety Administration (NHTSA) regulations for operation on public streets, roads and highways. Familiarize yourself with all laws and regulations concerning the operation of this vehicle in your area.

The following signal words and symbols appear throughout this manual and on your vehicle. Your safety is involved when these words and symbols are used. Become familiar with their meanings before reading the manual.

Product and specifications are subject to change without notice.

## **1. INTRODUCTION**

---

### **Important Safety Notice**

- Check the laws and regulations in force before choosing where to operate this vehicle. It is illegal to operate this vehicle on public lands where vehicles its size are prohibited.
- Never make any modifications to the drive system, mechanical or electrical systems of your CUV. Never install aftermarket parts or accessories intended to increase the speed or power of your CUV.
- Failure to follow these warnings increases the possibility of accidents leading to **DEATH** or **SERIOUS INJURY!**
- Additionally, failure to follow these requirements will void the Warranty on your CUV.

#### **NOTE**

The addition and use of certain accessories including, (but not limited to) mowers, blades, sprayers and windshields will change the handling characteristics and the performance of your CUV.

### **Practice Responsible CUV Riding**

Make sure that you understand and follow all local, state/province, and federal/national riding laws and requirements.

Remember.....Respect your vehicle, respect the environment and respect the property of others. You are responsible for your safety and the safety of others around you when you ride!

## 1. INTRODUCTION

---

**A CUV CAN BE HAZARDOUS TO OPERATE.** A CUV handles differently from other vehicles including motorcycles, ATVs and cars. A collision rollover can occur quickly, even during routine maneuvers such as turning and driving on hills or over obstacles, if you fail to take proper precautions.



**SERIOUS INJURY OR DEATH** can result if you do not follow these instructions.

- Read this manual and all labels carefully and follow the operating procedures described.
- This vehicle is designed to carry the driver and one passenger. Never carry passengers in the cargo bed.
- Always be sure the driver and passenger are wearing seat belts.
- Never allow anyone who is not an adult to operate this CUV.
- Never permit a guest to operate this CUV unless the guest has read this manual and all product labels.
- The driver and passenger must wear approved off-road motorcycle -type helmets that fits properly. The driver and passenger should also wear eye protections (goggles or face shields), gloves, boots, long-sleeved shirts or jackets, and long pants.
- If you are in a situation where the vehicle is tipping over, do not put your arm or/ and leg outside the vehicle, do not try to stop tipping with your arm or leg. You could be severely injured. You could suffer a crushed hand, arm, leg, or foot, if part of your body is caught underneath the vehicle.  
You must keep your arms and legs inside the vehicle until it has stopped moving.
- Never consume alcohol or drugs before or while operating this CUV.
- Never operate at excessive speeds. Always travel at a speed which is proper for the terrain, visibility and operating conditions, and your experience.
- Never attempt wheelies, jumps or other stunts.
- Always inspect your CUV each time you use it to make sure it is in safe operating condition. Always follow the inspection and maintenance procedures and schedules described in this manual.
- Always keep both hands, arms, feet, and legs inside the vehicle at



## 1. INTRODUCTION

---

all times during operation. Keep your feet on the floorboard. Never hold onto the enclosure except when using the handgrip inside the enclosure. Otherwise, your hand could be injured if it is caught between the enclosure and an obstacle outside the vehicle.

- Always keep both hands on the steering wheel when driving.
- Always go slowly and be extra careful when operating on unfamiliar terrain. Always be alert to changing terrain conditions when operating the CUV.
- Never operate on excessively rough, slippery or loose terrain.
- Always follow proper procedures for turning as described in this manual. Practice turning at low speeds before attempting to turn at faster speeds. Do not turn at excessive speed.
- Always have the CUV checked by an authorized dealer if it has been involved in an accident.
- Always check for obstacles before operating in a new area. Never attempt to operate over obstacles, such as large rocks or fallen trees. Always follow proper procedures when operating over obstacles as described in this manual.
- Always be careful of skidding or sliding. On slippery surfaces, such as ice, go slowly and be very cautious in order to reduce the chance of skidding or sliding out of control.
- Always be sure there are no obstacles or people behind you when you operate in reverse. When it is safe to proceed in reverse, go slowly. Avoid turning at sharp angles in reverse.
- Always use the size and type tires specified in this manual. Always maintain proper tire pressure as described in this manual.
- Never modify A CUV through improper installation or use of accessories.
- Never exceed the stated load capacity. Cargo should be as far forward in the bed as possible, and distributed evenly from side to side. Be sure cargo is secured so that it cannot move around during operation. Reduce speed and follow instructions in this manual for carrying cargo or pulling a trailer. Allow greater distance for braking.
- **Avoid operating the CUV through water. There is a risk of short circuit or leakage from wading driving the vehicle. It might lead to operator and passenger severe injured or dead, vehicle damaged or even ignited.**
- **Always operate the vehicle on the smooth terrain. It might lead to operator and passenger severe injured or dead, the damage of the**

## **1. INTRODUCTION**

---

suspension, battery , circuit and motor while driving on extreme off-road terrain , extreme slopes or jumping .

## 2. UNDERSTANDING WARNINGS

---

### ATTENTION:

This is an ADULT VEHICLE ONLY! Not a toy! READ AND UNDERSTAND WARNINGS AND OWNER'S MANUAL BEFORE OPERATION.



**KNOW YOUR VEHICLE BEFORE YOU BEGING RIDING!**

Read this manual thoroughly referring to the various areas which are being discussed on your machine. Operating this vehicle carries with it responsibilities for your personal safety, the safety of others, and the protection of our environment.

---

**NOTE:** Illustrations used in this manual are for general representation only. Your model may differ.

---

## 2. UNDERSTANDING WARNINGS

---

### SAFETY ALERT

**WARNINGS** identify special instructions or procedures which, if not correctly followed, could result in personal injury, or loss of life. Read all **WARNINGS** in this manual care fully. Follow their instructions to remain safe.

The following precautionary signal words are used throughout this manual to convey the following messages:

 This is the safety alert symbol. When you see this symbol on your machine or in this manual, be alert to the potential for personal injury. Your safety is involved!

 **WARNING**

Indicates a potential hazard which could result in severe injury or death.

 **CAUTION**

Indicates a potential hazard which may result in minor personal injury or damage to the CUV.

**CAUTION**

Indicates a situation that can result in damage to the machine.

**NOTE** The word “NOTE” in this manual will alert you to key information or instructions.



The Prohibition Safety Sign indicates an action NOT to taken in order to avoid a hazard.

### 3. SAFETY WARNING

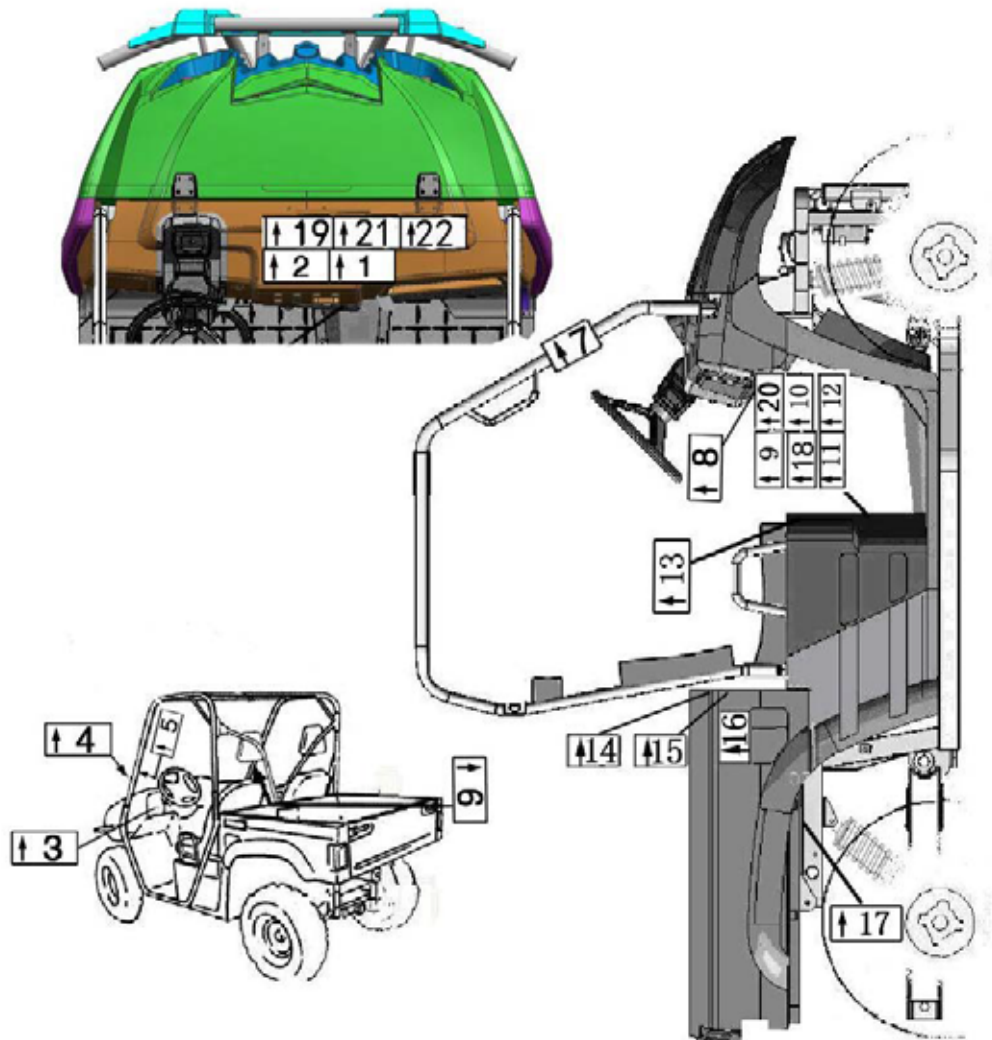

**NOTE:**

Warning decals have been placed on the vehicle for your protection. Read and follow the instructions on each decal carefully. In the event any decal becomes illegible or comes off, contact your dealer for a replacement.

**Attention:** There is a risk of fire from driving the vehicle on the ground where grass has dried up or parking the vehicle on such surface while the engine is hot.

### 3. SAFETY WARNING

1

**WARNING**

**IMPROPER VEHICLE USE CAN RESULT IN SEVERE INJURY OR DEATH.**

NEVER Operate:

- At speeds too fast for your skills or the conditions.
- After or while using Alcohol or Drugs.
- On extreme off-road terrain or extreme slopes.
- On public roads, a collision can occur with another vehicle.
- With more than one passenger, or a passenger under age twelve or who cannot comfortably reach the floor and hand holds.
- With non-producer's approved accessories - they may seriously affect stability.

ALWAYS:

- Wear your seat belt, if equipped. Vehicle rollover could cause severe injury or death.
- Wear a helmet and eye protection and keep hands and feet in vehicle at all times.
- Reduce speed and use extreme caution when carrying a passenger.
- Avoid sharp turns or turns while applying heavy throttle.
- Operate slowly in reverse - avoid sharp turns or sudden braking.
- Make sure passenger reads and understands all safety labels.
- Watch for branches or other hazards that could enter vehicle.

T02607

### 3. SAFETY WARNING

2

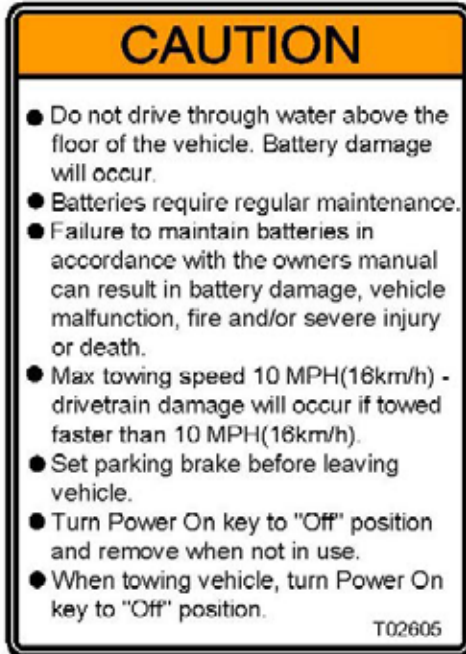

3



4

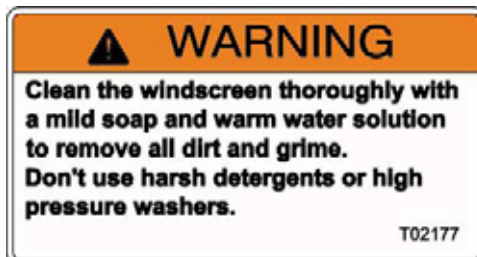

### 3. SAFETY WARNING

5

<b>⚠ WARNING</b>	
	<p>You could be severely injured if you try to stop a vehicle tip over using your arm or leg. If vehicle starts to tip over, keep arms and legs inside vehicle.</p> <p>Slopes, uneven terrain, and turning too fast or sharp increase the risk of tip over.</p> <p style="text-align: right;"><b>T02054</b></p>

6

<b>⚠ WARNING</b>	
	<p>You could be severely injured if you try to stop a vehicle tip over using your arm or leg. If vehicle starts to tip over, keep arms and legs inside vehicle.</p> <p>Slopes, uneven terrain, and turning too fast or sharp increase the risk of tip over.</p> <p style="text-align: right;"><b>T02055</b></p>

7

<b>⚠ WARNING</b>	
<p>The enclosure cannot protect occupants in all foreseeable accidents, including rollover.</p> <p style="text-align: right;"><b>T02049</b></p>	

8

<b>⚠ WARNING</b>	
<p>Never switch from "ECON" to "SPORT" or from "SPORT" to "ECON" while the vehicle is in motion.</p> <p style="text-align: right;"><b>T02613</b></p>	

9

<b>⚠ WARNING</b>	
	
<ul style="list-style-type: none"> <li>● Always charge the battery in dry conditions with the vehicle in dry state.</li> <li>● Prohibit battery charging outdoors in rainy days.</li> </ul> <p style="text-align: right;"><b>T02603</b></p>	



### 3. SAFETY WARNING

10



11

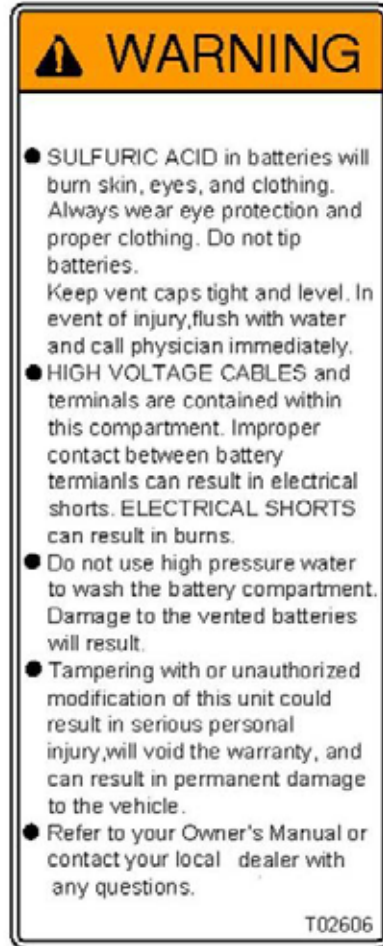

12

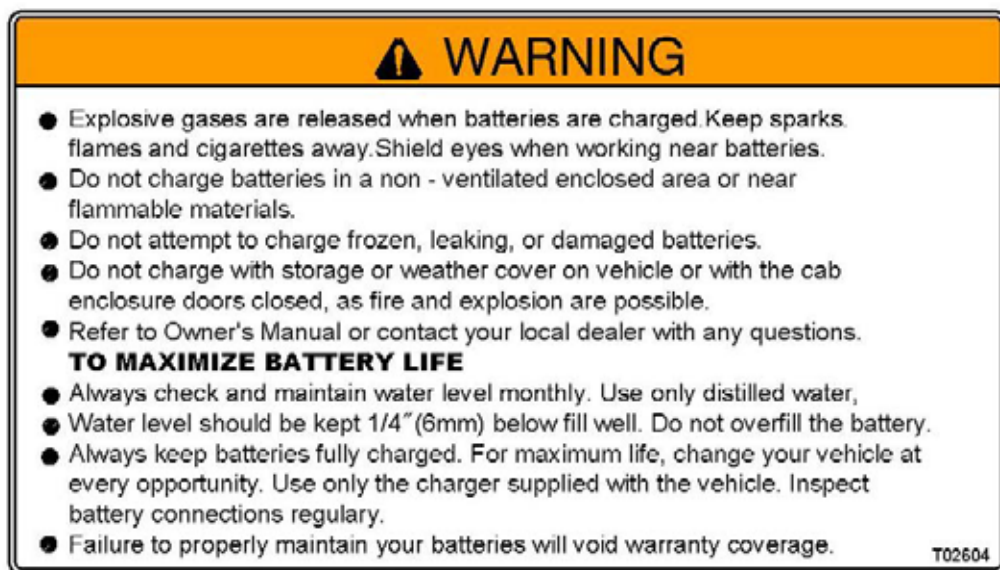

### 3. SAFETY WARNING

13

## NOTE

- The battery of the vehicle is usually supplied by the distributor.
- The Manufacturer of Linhai suggests to equip with 5 pcs batteries. Each battery's specification is 12V 150Ah and size is 330mmX170mmX290mm.
- Before operating this vehicle, the owner and each operator must have read and have an understanding of the instructions for proper assembly and safe operation.

T02609

14

## ⚠ WARNING



- Passengers can be thrown off. This can cause serious injury or death.
- Never carry passengers in cargo box.

T02058

### 3. SAFETY WARNING

15



16



17



### 3. SAFETY WARNING

18



19

<b>CAUTION</b>	
<p><b>Parking on an incline</b> Avoid parking on an incline if possible. If its unavoidable, follow these precautions:</p> <ol style="list-style-type: none"> <li>1. Apply the brakes.</li> <li>2. Set the park brake.</li> <li>3. Place the direction selector in neutral.</li> <li>4. Turn the key off.</li> <li>5. Block the rear wheels on the downhill side.</li> </ol>	<p><b>Driving on an incline</b></p> <p>1. Upslope Loosen the accelerator during upslope with forward gear, the motor start to work to avoid the backward slip by drag vehicle. The time limited is 3 minutes. The driver must stay in the vehicle and braking. Keep upslope only need step accelerator. If driver needs stop the vehicle needs use the parking method which above mentioned. It is absolute prohibition to use motor braking instead of slope braking.</p> <p>2. Down slope Down slope needs brake and reverse gear. The motor starts to work to avoid the forward slip by drag vehicle. The time limited is 3 minutes. The driver must stay in the vehicle and braking. Keep down slope only need step accelerator. If driver needs stop the vehicle needs use the parking method which above mentioned. It is absolute prohibition to use motor braking instead of slope braking.</p>
<p><small>If user do not take prevention recommended in the above mentioned, it will cause death, serious personal or equipment accident.</small></p>	
<p><small>T02657</small></p>	

20

**WARNING**

Please check the charging interface before each charge. Stop charging immediately if there is a fever, deformation or other abnormal situation.

T02661

21 (ONLY FOR USA )

**WARNING**

**Improper Use of Off-Highway Vehicles Can Cause Severe Injury or Death**

**Be Prepared**

- Fasten seat belts.
- Wear an approved helmet and protective gear.
- Reserved for message about other occupant restraint devices.
- Each rider must be able to sit with back against seat, feet flat on floor and foot rests, and hands on steering wheel or handhold where equipped. Stay completely inside the vehicle.

**Drive Responsibly**

Avoid loss of control and rollovers:

- Avoid abrupt maneuvers, sideways sliding, skidding, or fishtailing, and never do donuts.
- Slow down before entering a turn.
- Avoid hard acceleration when turning, even from a stop.
- Plan for hills, rough terrain, ruts, and other changes in traction and terrain. Avoid paved surfaces.
- Avoid side hilling (riding across slopes).

**Be Sure Riders Pay Attention and Plan Ahead**

If you think or feel the vehicle may tip or roll, reduce your risk to injury:

- Keep a firm grip on the steering wheel or handholds and brace yourself.
- Do not put any part of your body outside of the vehicle for any reason.

**Require Proper Use of Your Vehicle**

Do your part to prevent injuries :

- Do not allow careless or reckless driving.
- Make sure operators are 16 or older with a valid driver's license.
- Do not let people drive or ride after using alcohol or drugs.
- Do not allow operation on public roads (unless designated for off-highway vehicle access)--collision with cars and trucks can occur .
- Do not exceed seating capacity: one passenger.

Rollovers have caused severe injuries and death, even on flat, open areas.

**LOCATE AND READ THE OWNER'S MANUAL FOLLOW ALL INSTRUCTION AND WARNINGS**  
**RESERVED FOR REFERENCE TO OTHER SOURCE OF SAFETY INFORMATION**

T02659

### 3. SAFETY WARNING

---

22

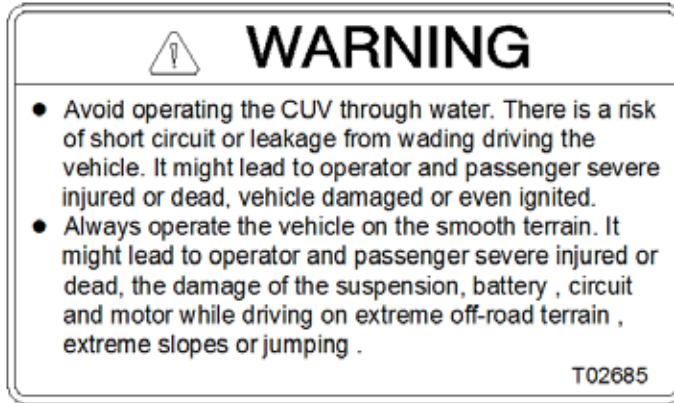

## 4. DAILY PRE-RIDE INSPECTION



### WARNING

You must inspect your CUV each time before riding to ensure it is in proper working order. If proper inspection is not done, severe injury or death could result.

Use the following checklist to verify your machine is in proper working order each time you ride.

### ITEM/ INSPECTION PROCEDURE

**1, Tire**— check condition and pressures.

**2, Batteries**— check the batteries, charge the batteries to its proper power.

**3, All brakes** — check fluid level, check operation, adjustment (includes parking brake).

● Brake pedal

Check for correct brake pedal free play. If the brake pedal free play is incorrect, have an authorized dealer adjust it. Check the operation of the brake pedal. It should move smoothly and there should be a firm feeling when the brakes are applied. If not, have the vehicle inspected by your dealer.

● Brake fluid leakage

Check to see if any brake fluid is leaking out of the pipe joints or the brake fluid reservoir. Apply the brakes firmly for one minute. If there is any leakage, have the vehicle inspected by an authorized dealer.

Brake fluid level

● Check the brake fluid level.

Add fluid if necessary.

● Brake operation

Test the brakes at slow speed after starting out to make sure they are working properly. If the brakes do not provide proper braking performance, inspect the brake system.

**4, Throttle/ Accelerator pedal**— check for free operation, closing and freeplay.

Check to see that the accelerator pedal operates correctly. It must

## 4. DAILY PRE-RIDE INSPECTION

---

operate smoothly and fully spring back to the idle position when released.

Have an authorized dealer repair as necessary for proper operation.

**5, Headlight / Taillight / Brake light**— check operation of all indicator lights and switches.

**6, The motor stop switch**— check for proper function.

**7, Wheels**— check for tightness of wheel nuts and axle nuts; check those axle nuts are secured by cotter pins.

Check balance/ damage/ run out. Have an authorized dealer repair/ replace if necessary.

Check bearing assemblies for looseness/damage. Have an authorized dealer replace if damaged.

**8, Steering**— check for free operation noting any unusual looseness in any area.

Park on level ground. Turn the steering wheel right and left. Check for excessive free play, abnormal noises, or a rough feeling. Have an authorized dealer repair as necessary for proper operation.

**9, Loose parts** — visually inspect vehicle for any damaged components or loose nuts/bolts or fasteners.

Always check the tightness of chassis fittings and fasteners before a ride. Take the vehicle to your dealer for correct tightening torque.

**10, Operator's and passenger's helmets, goggles and clothing.**

**11, Seat belts**— Check for proper operation and belt wear.

Make sure that both seat belts are not frayed or damaged. The seat belt must move smoothly when pulled out and retract on its own when released. The latch plate should click securely into the buckle and release when the release button is pushed firmly. Clean off any dirt or mud which could affect operation. Have an authorized dealer repair as necessary for proper operation.

## 5. OPERATION WARNINGS

---



### **WARNING**

#### **POTENTIAL HAZARD**

Malfunction of the accelerator pedal.

#### **WHAT CAN HAPPEN**

The accelerator pedal could be hard to operate, making it difficult to speed up or slow down when you need to. This could cause an accident.

#### **HOW TO AVOID THE HAZARD**

Check the operation of the accelerator pedal before you start the power. If it does not work smoothly, check for the cause. Correct the problem before operating the vehicle. Consult an authorized dealer if you can't find or solve the problem yourself.



### **WARNING**

#### **POTENTIAL HAZARD**

A loose seat.

#### **WHAT CAN HAPPEN**

The operator could lose control or the operator or passenger could fall if the seat is loose during operation.

#### **HOW TO AVOID THE HAZARD**

Make sure the seat is securely latched.



### **WARNING**

#### **POTENTIAL HAZARD**

Not wearing the seat belt.

Wearing the seat belt improperly.

#### **WHAT CAN HAPPEN**

There is increased risk of being killed or seriously injured in an accident.

#### **HOW TO AVOID THE HAZARD**

Always wear your seat belt when riding in the vehicle.

Be sure the seat belt is close-fitting across your hips and chest and is latched securely.



## 5. OPERATION WARNINGS

---



### **WARNING**

#### **POTENTIAL HAZARD**

Try to stop the tipping vehicle with your arm or leg.

#### **WHAT CAN HAPPEN**

You could be severely injured. You could suffer a crushed hand, arm, leg, or foot,

#### **HOW TO AVOID THE HAZARD**

You must keep your arms and legs inside the vehicle until it has stopped moving.

If you are in a situation where the vehicle is tipping over, do not put your arm or/ and leg outside the vehicle, do not try to stop tipping with your arm or leg. You could be severely injured. You could suffer a crushed hand, arm, leg, or foot, if part of your body is caught underneath the vehicle.



### **WARNING**

#### **POTENTIAL HAZARD**

Pinch points.

#### **WHAT CAN HAPPEN**

You or someone else could be pinched between the cargo bed and the frame when the bed is being lowered.

#### **HOW TO AVOID THE HAZARD**

Before closing the bed, be sure others are standing away from the vehicle. Keep hands and fingers away from the pinch points between the bed and the frame.

## 5. OPERATION WARNINGS



### WARNING

#### POTENTIAL HAZARD

Overloading the cargo bed

#### WHAT CAN HAPPEN

Could cause changes in vehicle handling which could lead to an accident.

#### HOW TO AVOID THE HAZARD

Never exceed the stated maximum load limit for this cargo bed.

Cargo should be properly distributed and securely attached.

Reduce speed when carrying cargo. Allow greater distance for braking.



### WARNING

#### POTENTIAL HAZARD

Carrying a passenger/ passengers in the cargo bed

#### WHAT CAN HAPPEN

The passenger(s) could fall, be thrown out, or be struck by objects in the cargo bed.

#### HOW TO AVOID THE HAZARD

Never carry a passenger/ passengers in the cargo bed. This cargo bed is designed to carry cargo only.



### WARNING

#### POTENTIAL HAZARD

Improper shock absorber adjustment.

#### WHAT CAN HAPPEN

Uneven adjustment can cause poor handling and loss of stability, which could lead to an accident.

#### HOW TO AVOID THE HAZARD

Always adjust the shock absorbers on the left and right side to the same setting.

## 5. OPERATION WARNINGS



### WARNING

#### POTENTIAL HAZARD

Driving with improperly operating brakes.

#### WHAT CAN HAPPEN

You could lose braking ability, which could lead to an accident.

#### HOW TO AVOID THE HAZARD

Always check the brakes at the start of every ride. Do not operate the vehicle if you find any problem with the brakes. If a problem cannot be corrected by the adjustment procedures provided in this manual, have the vehicle inspected by an authorized dealer.



### WARNING

#### POTENTIAL HAZARD

Operating vehicle without being familiar with all controls.

#### WHAT CAN HAPPEN

Loss of control, which could cause an accident or injury.

#### HOW TO AVOID THE HAZARD

Read the Owner's Manual carefully. If there is a control or function you do not understand, ask our authorized dealer.



### WARNING

#### POTENTIAL HAZARD

Freezing control cables in cold weather.

#### WHAT CAN HAPPEN

You could be unable to control the vehicle, which could lead to an accident or collision.

#### HOW TO AVOID THE HAZARD

When riding in cold weather, always make sure all control cables work smoothly before you begin riding.



### WARNING

## 5. OPERATION WARNINGS

---

### POTENTIAL HAZARD

Overloading this vehicle or carrying or towing cargo improperly.

### WHAT CAN HAPPEN

Could cause changes in vehicle handling which could lead to an accident.

### HOW TO AVOID THE HAZARD

Never exceed the stated load capacity for this vehicle.

Cargo should be properly distributed and securely attached.

Reduce speed when carrying cargo or pulling a trailer. Allow greater distance for braking.



### WARNING

### POTENTIAL HAZARD

Operating this vehicle with improper modifications.

### WHAT CAN HAPPEN

Improper installation of accessories or modification of this vehicle may cause changes in handling which in some situations could lead to an accident.

### HOW TO AVOID THE HAZARD

Never modify this vehicle through improper installation or use of accessories. All parts and accessories added to this vehicle should be genuine parts or equivalent components designed for use on this vehicle and should be installed and used according to instructions. If you have questions, consult an authorized dealer.



### WARNING

## 5. OPERATION WARNINGS

---

### POTENTIAL HAZARD

Operating with improperly serviced or adjusted brakes.

### WHAT CAN HAPPEN

You could lose braking ability, which could lead to an accident.

### HOW TO AVOID THE HAZARD

After servicing:

- Make sure the brakes operate smoothly and that the brake pedal position is correct.
- Make sure the brakes do not drag.
- All air must be bled from the brake system.

Replacement of brake components requires professional knowledge. These procedures should be performed by an authorized dealer.



### WARNING

### POTENTIAL HAZARD

Damaged control cables.

### WHAT CAN HAPPEN

Corrosion can result when the outer covering of control cables becomes damaged. Cables can also become frayed or kinked. Operation of controls could be restricted, which could cause an accident or injury.

### HOW TO AVOID THE HAZARD

Inspect cables frequently. Replace damaged cables.



### WARNING

## 5. OPERATION WARNINGS

---

### POTENTIAL HAZARD

Failure to handle batteries or battery electrolyte carefully.

### WHAT CAN HAPPEN

You could be poisoned. You could be severely burned by the sulfuric acid in battery electrolyte. Batteries produce explosive gases.

### HOW TO AVOID THE HAZARD

Avoid contact with skin, eyes or clothing. Always shield eyes when working near batteries. Keep out of reach of children.

Antidote:

EXTERNAL: Flush with water.

INTERNAL: Drink large quantities of water or milk. Follow with milk of magnesia, beaten egg or vegetable oil. Get prompt medical attention.

EYES: Flush with water for 15 minutes and get prompt medical attention. Keep batteries away from sparks, flames, cigarettes or other sources of ignition. Ventilate when charging or using in a closed space.



### WARNING

### POTENTIAL HAZARD

Using an improper fuse

### WHAT CAN HAPPEN

An improper fuse can cause damage to the electrical system, which could lead to a fire.

### HOW TO AVOID THE HAZARD

Always use a fuse of the specified rating. Never use a material in place of the proper fuse.



### WARNING

## 5. OPERATION WARNINGS

---

### POTENTIAL HAZARD

A headlight bulb is hot when it is on and immediately after it is turned off.

### WHAT CAN HAPPEN

You can be burned, or a fire could start if the bulb touches something flammable.

### HOW TO AVOID THE HAZARD

Wait for the bulb to cool before touching or removing it.



## WARNING

### POTENTIAL HAZARD

Operation with wet brakes after washing.

### WHAT CAN HAPPEN

Wet brakes may have reduced stopping ability, increasing the chance of an accident.

### HOW TO AVOID THE HAZARD

Test the brakes after washing. Apply the brakes several times at slow speeds to let friction dry out the linings.



## WARNING

## 5. OPERATION WARNINGS

---

### POTENTIAL HAZARD

Operating/ riding this CUV without wearing an approved helmet, eye protection and protective clothing.

### WHAT CAN HAPPEN

Operating/ riding without an approved helmet increases your chances of a severe head injury or death in the event of an accident.

Operating/ riding without eye protection can result in an accident and increases your chances of a severe injury in the event of an accident.

### HOW TO AVOID THE HAZARD

Always wear an approved helmet which fits properly.

You should also wear: eye protection (goggles or face shield); gloves; boots; long-sleeved shirt or jacket; and long pants.



### WARNING

### POTENTIAL HAZARD

Operating this CUV after consuming alcohol or drugs.

### WHAT CAN HAPPEN

Could seriously affect your judgment.

Could cause you to react more slowly.

Could affect your balance and perception.

Could result in an accident.

### HOW TO AVOID THE HAZARD

Never consume alcohol or drugs before or while driving this CUV.



### WARNING



## 5. OPERATION WARNINGS

---

### POTENTIAL HAZARD

Operating this CUV at excessive speeds.

### WHAT CAN HAPPEN

Increases your chances of losing control of the CUV, which can result in an accident.

### HOW TO AVOID THE HAZARD

Always travel at a speed which is proper for the terrain, visibility and operating conditions; and your experience.



### WARNING

### POTENTIAL HAZARD

Attempting wheelies, jumps and other stunts.

### WHAT CAN HAPPEN

Increases the chance of an accident, including an overturn.

### HOW TO AVOID THE HAZARD

Never attempt stunts, such as wheelies or jumps.



### WARNING

### POTENTIAL HAZARD

Failure to inspect the CUV before operating.

Failure to properly maintain the CUV.

### WHAT CAN HAPPEN

Increases the possibility of an accident or equipment damage.

### HOW TO AVOID THE HAZARD

Always inspect your CUV each time you use it to make sure the CUV is in safe operating condition.

Always follow the inspection and maintenance procedures and schedules described in the Owner's Manual.



### WARNING

### POTENTIAL HAZARD

## 5. OPERATION WARNINGS

Removing hands from steering wheel or feet from footrests during operation.

### WHAT CAN HAPPEN

Removing even one hand or foot can reduce your ability to control the CUV or could cause you to lose your balance and fall off the CUV.

### HOW TO AVOID THE HAZARD

Always keep both hands on the steering wheel and both feet on the footrests of your CUV during operation.



### WARNING

#### POTENTIAL HAZARD

Failure to use extra care when operating this CUV on unfamiliar terrain.

#### WHAT CAN HAPPEN

You can come upon hidden rocks, bumps, or holes, without enough time to react.

Could result in the CUV overturning or going out of control.

#### HOW TO AVOID THE HAZARD

Go slowly and be extra careful when operating on unfamiliar terrain.

Always be alert to changing terrain conditions when operating the CUV.



### WARNING

#### POTENTIAL HAZARD

## 5. OPERATION WARNINGS

Failure to use extra care when operating on excessively rough, slippery or loose terrain.

### WHAT CAN HAPPEN

Could cause loss of traction or vehicle control, which could result in an accident, including an overturn.

### HOW TO AVOID THE HAZARD

Do not operate on excessively rough, slippery or loose terrain until you have learned and practiced the skills necessary to control the CUV on such terrain.

Always be especially cautious on these kinds of terrain.



### WARNING

#### POTENTIAL HAZARD

Turning improperly.

#### WHAT CAN HAPPEN

CUV could go out of control, causing a collision or overturn.

#### HOW TO AVOID THE HAZARD

Always follow proper procedures for turning as described in the Owner's Manual.

Practice turning at low speeds before attempting to turn at faster speeds.

Do not turn at excessive speed.



### WARNING

#### POTENTIAL HAZARD

Operating on excessively steep hills.

## 5. OPERATION WARNINGS

---

### WHAT CAN HAPPEN

The vehicle can overturn more easily on extremely steep hills than on level surfaces or small hills.

### HOW TO AVOID THE HAZARD

Never operate the CUV on hills too steep for the CUV or for your abilities.

Practice on smaller hills before attempting large hills.

Never operate CUV on hills steeper than 15%.



### WARNING

### POTENTIAL HAZARD

Improperly operating over obstacles.

### WHAT CAN HAPPEN

Could cause loss of control or a collision. Could cause the CUV to overturn.

### HOW TO AVOID THE HAZARD

Before operating in a new area, check for obstacles.

Use extreme caution when riding over large obstacles, such as large rocks or fallen trees.

If you cannot avoid obstacles, always follow proper procedures as described in the Owner's Manual.



### WARNING

### POTENTIAL HAZARD

Skidding or sliding,

### WHAT CAN HAPPEN

You may lose control of the CUV.

You may also regain traction unexpectedly, which may cause the CUV to overturn.

### HOW TO AVOID THE HAZARD

On slippery surfaces, such as ice, go slowly and be very cautious in order to reduce the chance of skidding or sliding out of control.

## 5. OPERATION WARNINGS

---



### WARNING

#### POTENTIAL HAZARD

Improperly operating in reverse,

#### WHAT CAN HAPPEN

You could hit an obstacle or person behind you, resulting in severe injury.

#### HOW TO AVOID THE HAZARD

When you select reverse gear, make sure there are no obstacles or people behind you. When it is safe to proceed, go slowly.



### WARNING

#### POTENTIAL HAZARD

Operating this CUV with improper tires, or with improper or uneven tire pressure.

#### WHAT CAN HAPPEN

Use of improper tires on this CUV, or operation of this CUV with improper or uneven tier pressure, may cause loss of control, and increases the risk of an accident.

#### HOW TO AVOID THE HAZARD

Always use the size and type ties specified in the Owner's Manual for this vehicle.

Always maintain proper tire pressure a described in the Owner's Manual.

Use proper pressures stated on the side wall of the tire when seating the tire beads. Higher pressures may cause the tire to burst. Inflate the tires very slowly and carefully. Fast inflation could cause the tire to burst.

## 5. OPERATION WARNINGS

---



### **WARNING**

#### **POTENTIAL HAZARD**

Operating this CUV with improper modifications.

#### **WHAT CAN HAPPEN**

Improper installation of accessories or modification of this vehicle may cause changes in handling which in some situations could lead to an accident.

#### **HOW TO AVOID THE HAZARD**

Never modify this CUV through improper installation or use of accessories. All parts and accessories added to this vehicle should be genuine or equivalent components designed for use on this CUV; and should be installed and used according to instructions. If you have questions, consult our authorized dealer.



### **WARNING**

#### **POTENTIAL HAZARD**

Riding on frozen lakes and rivers.

#### **WHAT CAN HAPPEN**

Severe injury or death can result if the CUV and /or the operator break through the ice.

#### **HOW TO AVOID THE HAZARD**

Never ride you CUV on a frozen body of water.

## 5. OPERATION WARNINGS

---



### WARNING

After a rollover or an accident, have a qualified service dealer check the complete machine including, but not limited to, brakes, throttle and steering for possible damage.



### WARNING

Safe operation of this rider active vehicle requires good judgment and physical skills. Persons with cognitive or physical disabilities who operate this vehicle have an increased risk of overturns and loss of control which could result in severe injury or death.



### WARNING

#### POTENTIAL HAZARD

Operating this CUV on extreme off-road terrain , extreme slopes or jumping .

#### WHAT CAN HAPPEN

It might lead to operator and passenger severe injured or dead, the damage of the suspension, battery , circuit and motor.

#### HOW TO AVOID THE HAZARD

Operating this CUV on the smooth terrain.

## 5. OPERATION WARNINGS

---



### **WARNING**

#### **POTENTIAL HAZARD**

Operating the CUV through water.

#### **WHAT CAN HAPPEN**

There is a risk of short circuit or leakage from wading driving the vehicle. It might lead to operator and passenger severe injured or dead, vehicle damaged or even ignited.

#### **HOW TO AVOID THE HAZARD**

Operating this CUV on the dry terrain.



## 6. V.I.N. AND KEY

---

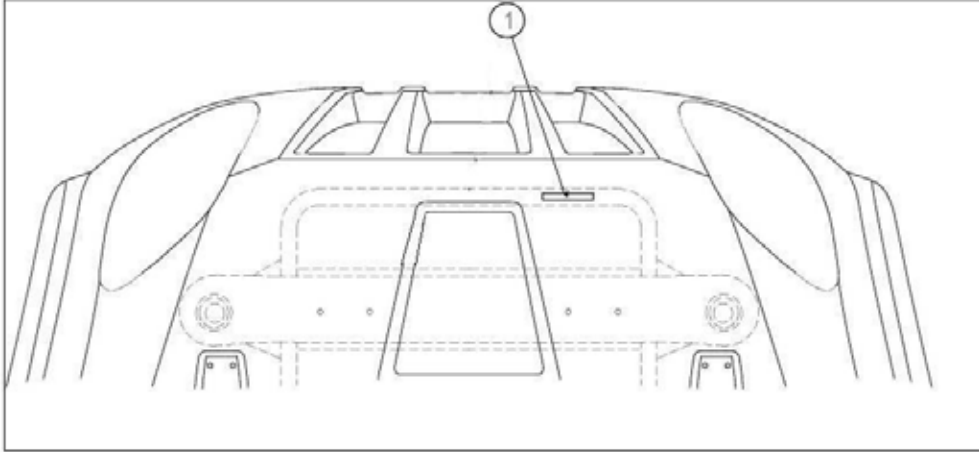

Record these numbers from your CUV in the spaces provided.

1. Frame VIN (found on the front of the frame tube)

--	--	--	--	--	--	--	--	--	--	--	--	--	--	--	--	--	--	--	--

**Remove the spare key and store in a safe place.** Your key can be duplicated only by obtaining a key blank and having it cut by mating it with your existing key.

Record Key Number

--	--	--	--	--	--	--	--	--	--	--	--	--	--	--	--	--	--	--	--	--

The vehicle frame is important for model identification when registering your vehicle, obtaining insurance or whenever replacement parts are required. In the event your vehicle were stolen these numbers are essential to the recovery and identification of your CUV.

## **7. CONTROL AND PARTS FUNCTIONS**

### **ELECTRICAL SWITCHES**

#### **Switch On Panel**

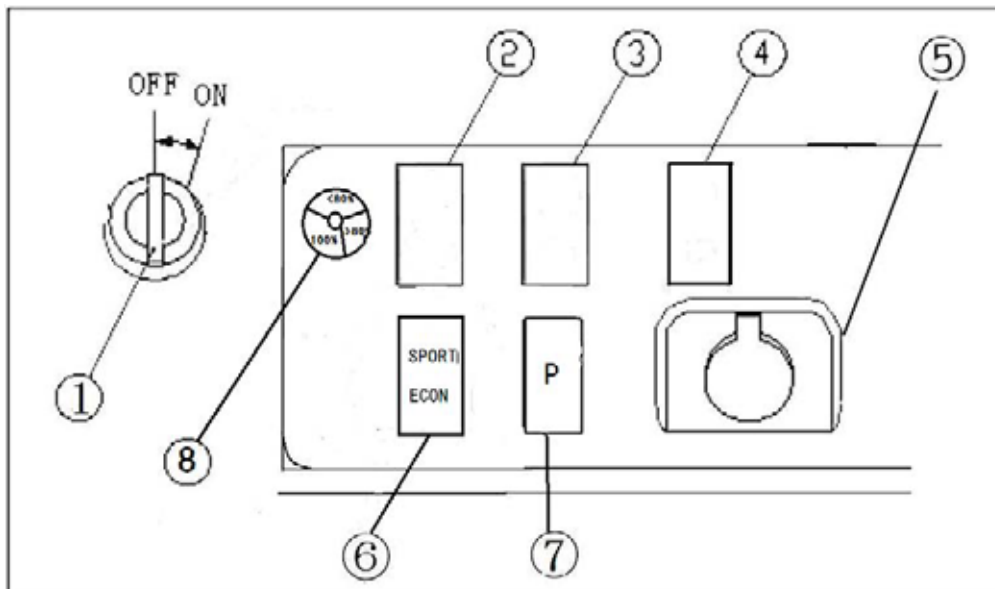

- 1, Main Switch      2, Blank      3, Blank  
 4, Blank      5, Accessory socket      6, Sport and econ Switch  
 7, Parking      8, Charging Indicator

#### 1, Main Switch

Functions of the respective switch positions are as follows:

ON: All electrical circuits are supplied with power.

OFF: All electrical circuits are switched off. The key can be removed in this position.



### **WARNING**

Use caution and drive at reduced speeds in conditions of reduced visibility such as fog, rain and darkness.

- 5, Accessory socket  
 6, Sport and econ Switch  
 7, Parking

## 7. CONTROL AND PARTS FUNCTIONS

Shift sports mode and economy mode.



### CAUTION

Always shift as the vehicle stop.

#### 8. Charging Indicator

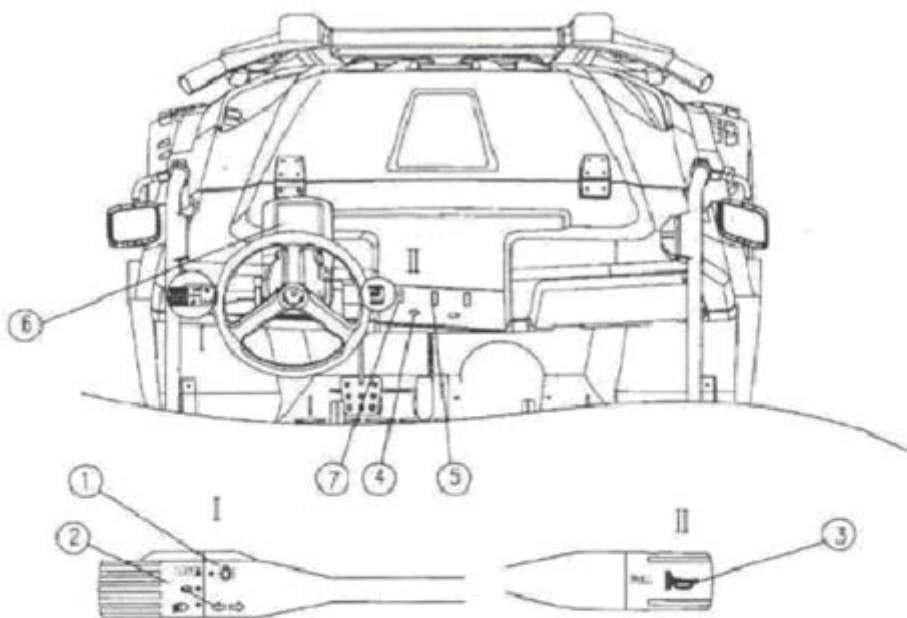

N	DESCRIPTION	
1	HIGH BEAM SWITCH	
2	TURN INDICATORS SWITCH	
3	HORN SWITCH	
4	IGNITION /START SWITCH	
5	EMERGENCY SWITCH	
6	LCD METER	
7	MODE SWITCH	

## 7. CONTROL AND PARTS FUNCTIONS

### LCDMETER

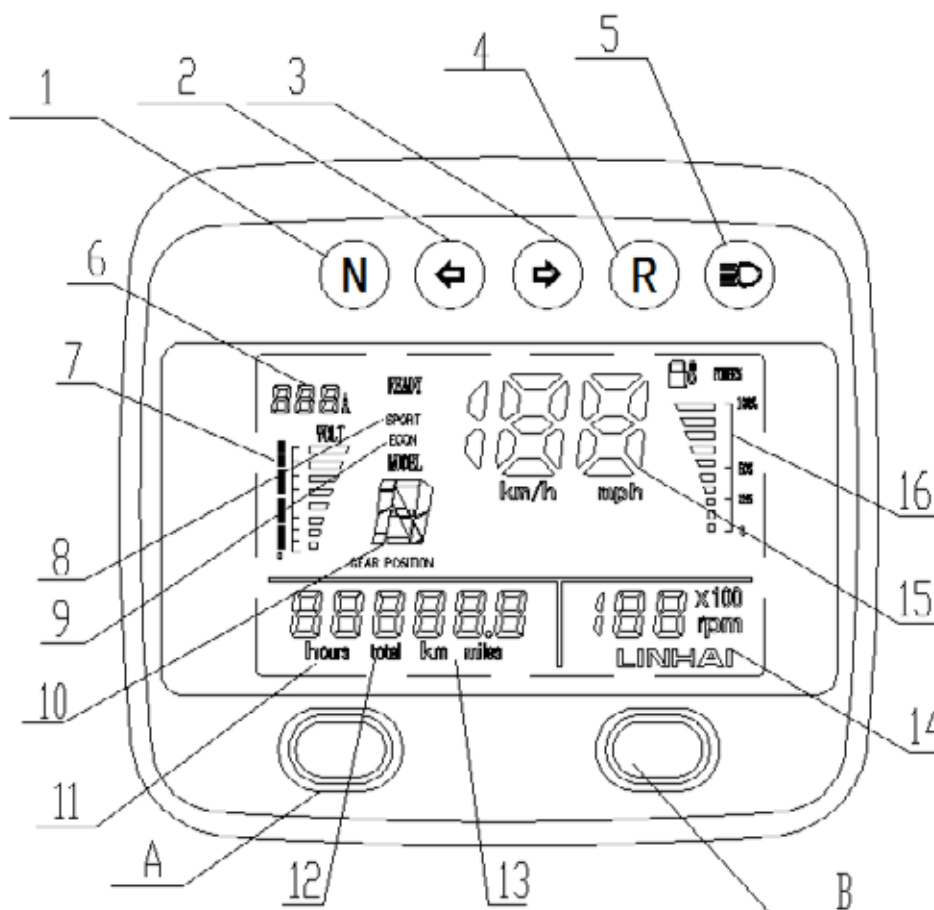

- |                                |                                       |
|--------------------------------|---------------------------------------|
| 1. Neutral indicator light     | 10. Gear position indicator           |
| 2. Turn indicator light(left)  | 11. <b>Motor</b> working hour counter |
| 3. Turn indicator light(right) | 12、 13. The odometer                  |
| 4. Reverse indicator light     | A: km/ mile selector                  |
| 5. High beam indicator light   | B: hour / distance selector           |
| 6. Currency                    | 14. <b>Motor</b> rpm meter            |
| 7. Volt                        | 15. Speedometer                       |
| 8. Sport mode                  | 16. Power Indicator                   |
| 9. Economy mode                |                                       |

### ACCESSORY SOCKET

The accessory socket (1) is attached



(1) Accessory socket (1) on

## **7. CONTROL AND PARTS FUNCTIONS**

to the left side of the front cover. You can use the accessory socket to power a trouble light, spotlight, CB radio, or cell phone etc.



### **CAUTION**

Do not plug in any heat-generating accessory such as an automobile cigarette lighter because it damages the socket.

To use the accessory socket, start the **motor**. Then turn the headlights OFF, and open the accessory socket cap (2).

Be sure the **motor** is on and the headlights are turned off before using the accessory socket, otherwise you may drain the battery.

The accessory socket is rated capacity is DC 12V. 120 Watts (10A) or less. If you exceed this limit, you may blow a fuse.

When you are done using an accessory, unplug it, and cover the socket with the cap.

Be careful not to flood this accessory socket when washing your CUV.

### **ACCELERATOR PEDAL**



### **WARNING**

Before starting the **motor**, check the accelerator pedal to be sure it is operating smoothly.

Make sure the accelerator pedal fully returns to the idle position as soon as it is released.

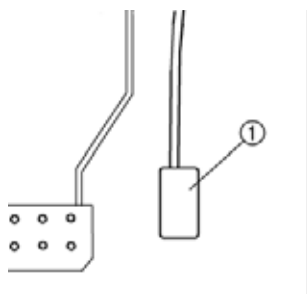

1. Accelerator pedal

Press the accelerator pedal down to increase **motor** speed. Spring pressure returns the pedal to the rest position when released. Always

## **7. CONTROL AND PARTS FUNCTIONS**

---

check that the accelerator pedal returns normally before starting the **motor**.



### **WARNING**

#### **POTENTIAL HAZARD**

Malfunction of the accelerator pedal.

#### **WHAT CAN HAPPEN**

The accelerator pedal could be hard to operate, making it difficult to speed up or slow down when you need to. This could cause an accident.

#### **HOW TO AVOID THE HAZARD**

Check the operation of the accelerator pedal before you start the **motor**. If it does not work smoothly, check for the cause. Correct the problem before operating the vehicle. Consult the authorized dealer if you can't find or solve the problem yourself.

---

### **BRAKE PEDAL**

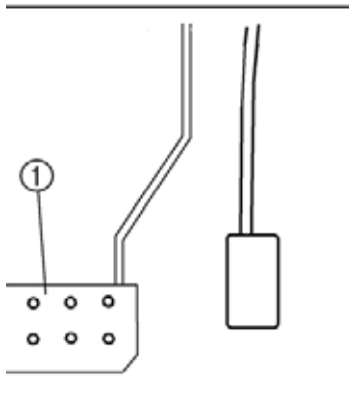

1.Brake pedal

Press the brake pedal to slow or stop the vehicle.



### **WARNING**

Never operate the CUV with a spongy feeling brake pedal. Operating the CUV with a spongy brake pedal can result in loss of braking. Loss of braking could cause an accident.

## 7. CONTROL AND PARTS FUNCTIONS

### PARKING BRAKE LEVER

The parking brake lever is located at the right side of the driver's seat. It will help hold the vehicle from moving while parked. To set the parking brake, pull the lever up completely. The parking indicator light will come on if the main switch is on. To release the parking brake, pull up on the lever, press the release button, and then push the lever all the way down. Be sure to fully release the parking brake before starting out. Failure to do so may result in poor performance and premature wearing of the parking brake and V-belt.

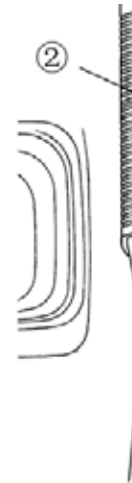

1. Release button
2. Parking brake lever

### AUTOMATIC TRANSMISSION GEAR SELECTOR OPERATION

The transmission gear selector is located at the right side of the driver's seat. The transmission selector lever has three positions: reverse; neutral; forward;

**NOTE:** To extend belt life, use low forward gear in heavy pulling situations and in situations where you are operating below 7mph(11km/h) for extended periods of time.

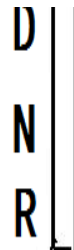

### SEATS

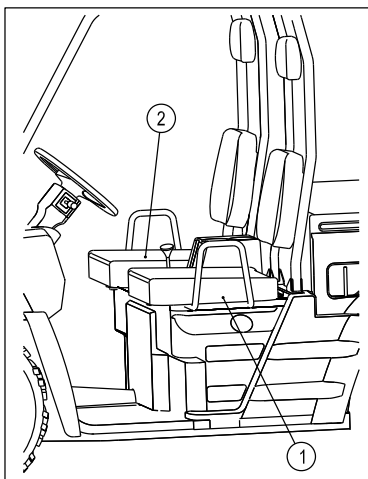

1. Drive seat
2. Passenger seat

To remove a seat, lift the front of the seat, and then slide the seat up and forward.

To install a seat, insert the projections on the rear of the seat into the seat holders and push down on the seat at the front.

## **7. CONTROL AND PARTS FUNCTIONS**



### **WARNING**

#### **POTENTIAL HAZARD**

A loose seat.

#### **WHAT CAN HAPPEN**

The operator could lose control or the operator or passenger could fall if the seat is loose during operation.

#### **HOW TO AVOID THE HAZARD**

Make sure the seat is securely latched.

### **SEAT BELTS**

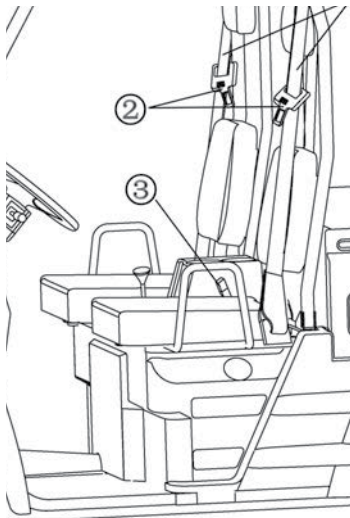

1. Seat belt (×2)

2. Latch plate (×2)

3. Buckle (×2)

This vehicle is equipped with three-point seat belts for both the operator and passenger. Always wear the seat belt while riding in the vehicle.

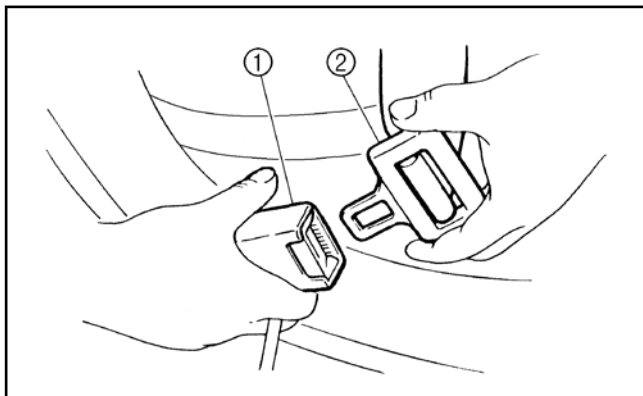

1. Buckle

2. Latch plate



## **7. CONTROL AND PARTS FUNCTIONS**

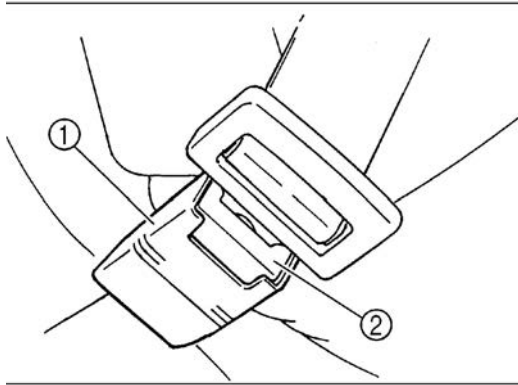

1. Buckle

2. Release button

**To Wear The Seat Belt Properly**, do the following:

1. Hold the latch plate as you pull the belt across your lap and chest. Make sure the belt is not twisted and is not caught on any portion of the vehicle, your clothing, or any equipment you are carrying.
2. Push the latch plate into the buckle until it clicks. Pull up on the latch plate to make sure it is secure.
3. Put the lap portion of the belt low on your hips. Push down on the buckle end of the belt as you pull up on the shoulder part so the belt is snug across your hips.
4. Position the shoulder belt over your shoulder and across your chest. The shoulder belt should fit against your chest. If it is loose, pull the belt out all the way and then let it retract.

**To Release The Buckle**, firmly press the release button.



### **WARNING**

#### **POTENTIAL HAZARD**

Not wearing the seat belt.

Wearing the seat belt improperly.

#### **WHAT CAN HAPPEN**

There is increased risk of being killed or seriously injured in an accident.

#### **HOW TO AVOID THE HAZARD**

Always wear your seat belt when riding in the vehicle.

Be sure the seat belt is close-fitting across your hips and chest and is

## 7. CONTROL AND PARTS FUNCTIONS

latched securely.

### GLOVE COMPARTMENT

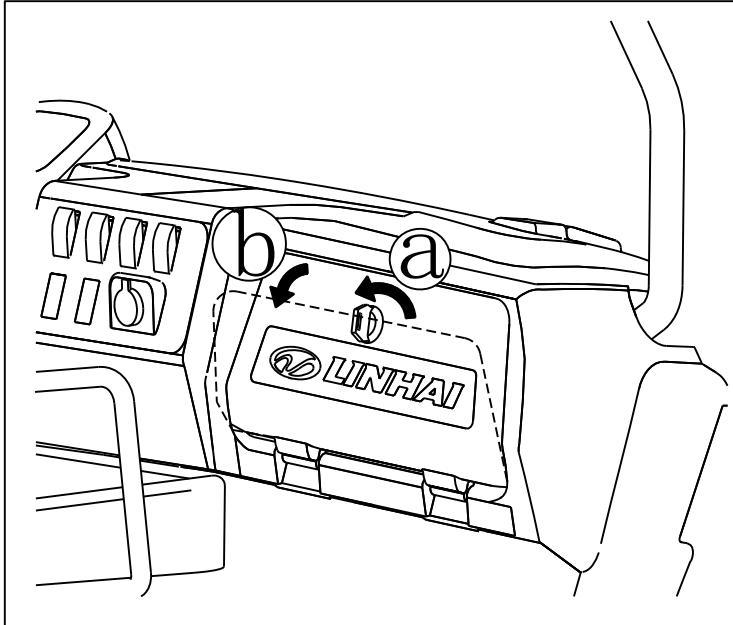

- a.Unlock
- b.Open



### CAUTION

To protect from damage, do not put metal products, like tools or sharply edged products directly in the glove compartment. If they must be stored, wrap them in appropriate cushion material.

### CARGO BED

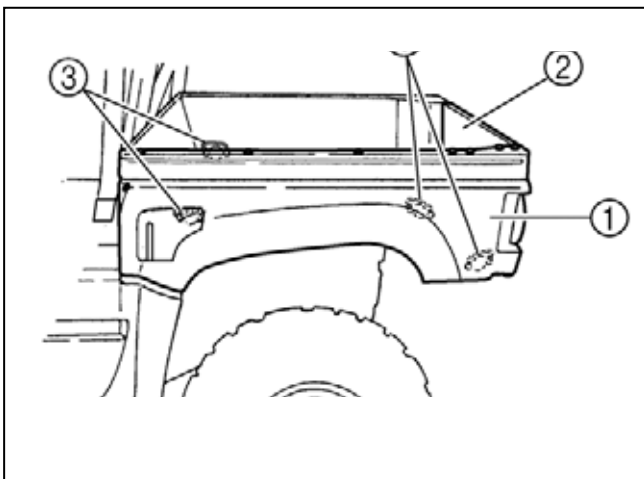

- 1.Cargo bed
- 2.Tailgate
- 3.Cargo hook (×4)

## **7. CONTROL AND PARTS FUNCTIONS**

### **Opening And Closing The Tailgate**

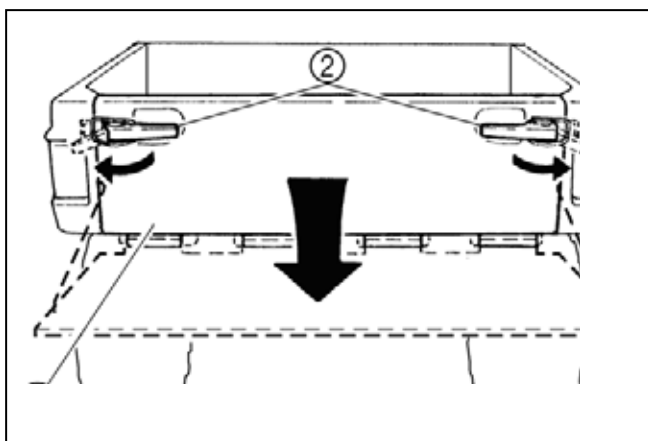

- 1.Tailgate
- 2.Latch (×2)

To open  
Unhook the latches,  
and then lower the  
tailgate.

To close  
Place the tailgate in the original position, and then hook the latches.

### **Lifting And Lowering The Cargo Bed**

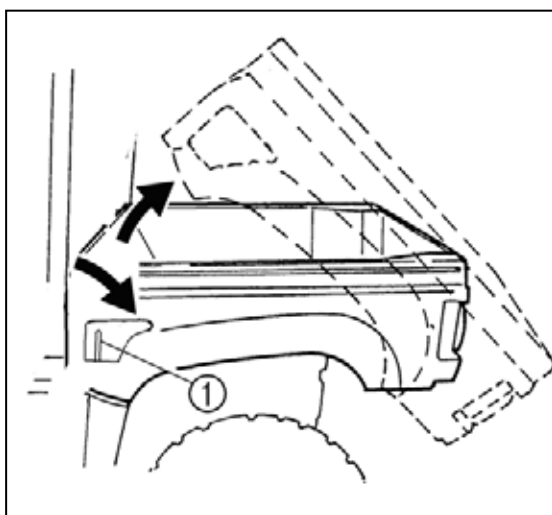

- 1.Cargo bed release lever

To lift  
Push down the cargo bed  
release lever on the left or  
right side of the vehicle, and

then slowly lift up the cargo bed until it stops.

To lower  
Lower the cargo bed slowly to its original position and be sure that it is  
locked into place.

## **7. CONTROL AND PARTS FUNCTIONS**

---



### **WARNING**

#### **POTENTIAL HAZARD**

Pinch points.

#### **WHAT CAN HAPPEN**

You or someone else could be pinched between the cargo bed and the frame when the bed is being lowered.

#### **HOW TO AVOID THE HAZARD**

Before closing the bed, be sure others are standing away from the vehicle. Keep hands and fingers away from the pinch points between the bed and the frame.

---

#### **Load Limit**

Maximum load limit: 150 kg (330 lb)



### **WARNING**

#### **POTENTIAL HAZARD**

Overloading the cargo bed

#### **WHAT CAN HAPPEN**

Could cause changes in vehicle handling which could lead to an accident.

#### **HOW TO AVOID THE HAZARD**

Never exceed the stated maximum load limit for this cargo bed. Cargo should be properly distributed and securely attached. Reduce speed when carrying cargo. Allow greater distance for braking.



### **WARNING**

#### **POTENTIAL HAZARD**

Carrying a passenger/ passengers in the cargo bed

#### **WHAT CAN HAPPEN**

The passenger(s) could fall, be thrown out, or be struck by objects in the cargo bed.

#### **HOW TO AVOID THE HAZARD**

Never carry a passenger/ passengers in the cargo bed. This cargo bed is designed to carry cargo only.

## **7. CONTROL AND PARTS FUNCTIONS**

---

### **HOOD**

#### **To Open**

Unhook the hood latches, and then slowly tilt the hood up until it stops.

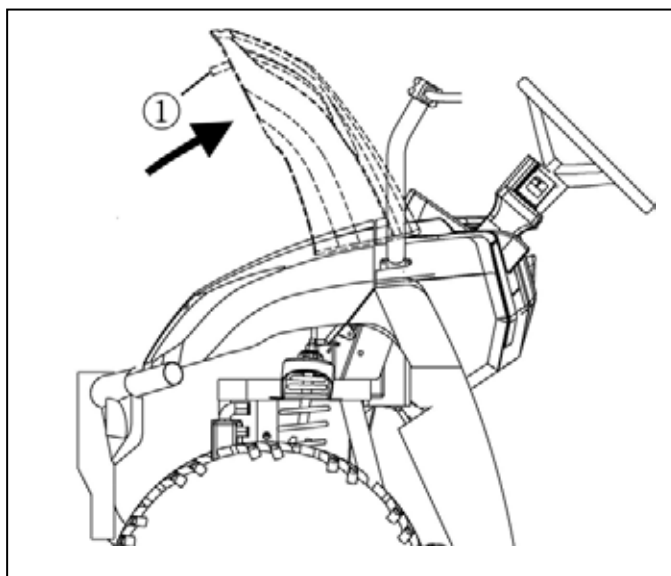

1.latch (×2)

#### **To Close**

Lower the hood slowly to its original position, and then hook the hood latches, and be sure that they are locked into place..



### **WARNING**

If the hood latches are hooked improperly, or the latches and their attachments can not work properly, the front hood can come off during operation, striking the driver or passenger and causing serious personal injury.

---

## **8. RIDING GEAR**

---

### **SAFE RIDING GEAR**

Always wear clothing suitable to the type of riding you are doing. CUV riding requires special protective clothing which will make you feel more comfortable and reduce chances of injury.

#### **1. Helmet**

Your helmet is the most important piece of protective gear for safe riding.

A helmet can prevent a severe head injury.

Select an approved off-road motorcycle -type helmets that fits properly.

#### **2. Eye Protection**

A pair of goggles or helmet face shield offer the best protection for your eyes.

#### **3. Gloves (off-road style)**

#### **4. Boots**

A pair of strong over the calf type boots with heels, such as motocross boots.

#### **5. Clothing**

To protect your body, long sleeves and pants should always be worn.

Riding pants with kneepads, a jersey and shoulder pads provide the best protection.

## 8. RIDING GEAR

---



### WARNING

#### **POTENTIAL HAZARD**

Operating this vehicle without wearing an approved motorcycle helmet, eye protection, and protective clothing.

#### **WHAT CAN HAPPEN**

Operating without an approved motorcycle helmet increases your chances of a severe head injury or death in the event of an accident. Operating without eye protection can result in an accident and increases your chances of a severe injury in the event of an accident.

#### **HOW TO AVOID THE HAZARD**

Always wear an approved motorcycle helmet that fits properly. You should also wear: eye protection (goggles or face shield), gloves, boots, long-sleeved shirt or jacket long pants.

---

## 9. CARRYING LOADS

---

### CARRYING LOADS

Cargo can change the stability and handling of a vehicle.

You must use common sense and good judgment when carrying cargo.

Keep the following points in mind:

- Never exceed the weight limits shown. An overloaded vehicle can be unstable.

<b>MAXIMUM LOADING LIMIT</b>
------------------------------

Cargo bed: 150 kg (330 lb)
----------------------------

- Load cargo in the cargo bed as close to the center of the vehicle as possible and tie it down using the cargo hooks equipped on the cargo bed.
- Make sure the load does not interfere with controls or your ability to see where you are going.
- Drive more slowly than you would without a load. The more weight you carry, the slower you should go. Although conditions vary, it is good practice not to exceed low range whenever you are carrying heavier loads or when towing a trailer.
- Allow more braking distance. A heavier vehicle takes longer to stop.
- Avoid making sharp turns unless at very slow speeds.
- Avoid hills and rough terrain. Choose terrain carefully. Added weight affects the stability and handling of the vehicle.

#### Use A Safety Chain

- A safety chain will help control drawn machinery should it separate from the tractor drawbar.
- Use a chain with the strength rating equal to or greater than the



## 9. CARRYING LOADS

---

gross weight of the towed machinery.

- Attach the chain to the tractor drawbar support or other specified anchor location. Allow only enough slack in the chain to permit turning.
- Do not use safety chain for towing.



### WARNING

#### POTENTIAL HAZARD

Overloading this vehicle or carrying cargo improperly.

#### WHAT CAN HAPPEN

Could cause changes in vehicle handling which could lead to an accident.

#### HOW TO AVOID THE HAZARD

Never exceed the stated load capacity for this vehicle. Cargo should be properly distributed and securely attached. Reduce speed when carrying cargo. Allow greater distance for braking.

---



### WARNING

#### POTENTIAL HAZARD

Carrying a passenger in the cargo bed.

#### WHAT CAN HAPPEN

The passenger could fall or be struck by objects in the cargo bed.

#### HOW TO AVOID THE HAZARD

## 9. CARRYING LOADS

---

Never carry a passenger in the cargo bed. The cargo bed is designed to carry cargo only.

---

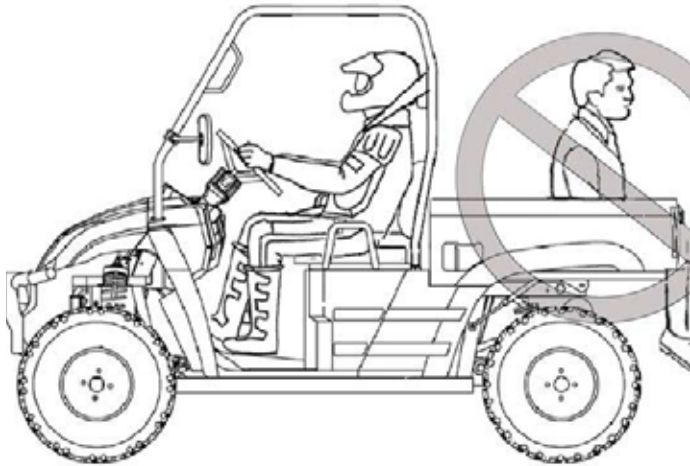

## 10. DRIVING YOUR VEHICLE

### GETTING TO KNOW YOUR VEHICLE

This utility vehicle will handle and maneuver differently from an ordinary passenger car or other vehicle. Before you begin to use your vehicle, be sure you have read this Owner's Manual completely and understand the operation of the controls. Pay particular attention to the safety information. Please also read all caution and warning labels on your vehicle. This vehicle is designed for the operator and one passenger. The driver and passenger must always wear a seat belt. Never carry passengers in the cargo bed.



### WARNING

#### POTENTIAL HAZARD

Not wearing the seat belt.  
Wearing the seat belt improperly.

#### WHAT CAN HAPPEN

There is increased risk of being killed or seriously injured in an accident.

#### HOW TO AVOID THE HAZARD

Always wear your seat belt when riding in the vehicle. Be sure the seat belt is close-fitting across your hips and chest and is latched securely.

#### Driving Procedure

1. Disconnect the charging cable (if connected).
2. All riders should wear substantial footwear, long pants and a close-fitting shirt. A hard hat or helmet and approved eye protection are recommended when appropriate for working or riding conditions.
3. Sit in the driver's seat.
4. Apply the brakes. Place the direction selector in neutral (N).
5. Apply the brakes. Turn the key to the ON position. Wait about a second for the contactor to close before continuing.
6. Move the direction selector to forward or reverse.
7. Release the park brake.
8. Check your surroundings and determine your path of travel.
9. Keeping both hands on the steering wheel, release the brake pedal and gradually push the accelerator toward the floor to begin driving.
10. Drive slowly. Practice maneuvering and using the accelerator and

## 10. DRIVING YOUR VEHICLE

---

brakes on level surfaces.

11. Do not carry a passenger until you have at least two hours of driving experience with this vehicle. Never carry more than one passenger in this vehicle. Never allow a passenger to ride in the cargo box.

12. To stop the vehicle, release the accelerator pedal completely and brake to a complete stop.

Tip: Always come to a complete stop before reversing direction.

13. Set the park brake.

14. Place the direction selector in neutral.

15. Turn the key off.

**WARNING!** A rolling vehicle can cause serious injury. Always set the park brake and remove the key when leaving the vehicle unattended.



### WARNING

You must inspect you CUV each time before riding to ensure it is in proper working order. If proper inspection is not done, severe injury or death could result.

See "4.DAILY PRE-RIDE INSPECTION"

---

### MAKING TURNS

It is possible for the vehicle to roll over or go out of control if you attempt sharp, high-speed turns. You should also be careful making sharp turns on rough terrain. Do not attempt to turn around or make abrupt maneuvers on slopes.

Position your hands on the steering wheel so that your thumbs and fingers do not wrap around the wheel. This is particularly important when driving in rough terrain. The front wheels will move right and left as they respond to the terrain, and this movement will be felt in the steering wheel. A sudden jolt could wrench the steering wheel around, and your thumbs or fingers could be injured if they are in the way of the steering wheel spokes.

## 10. DRIVING YOUR VEHICLE

---

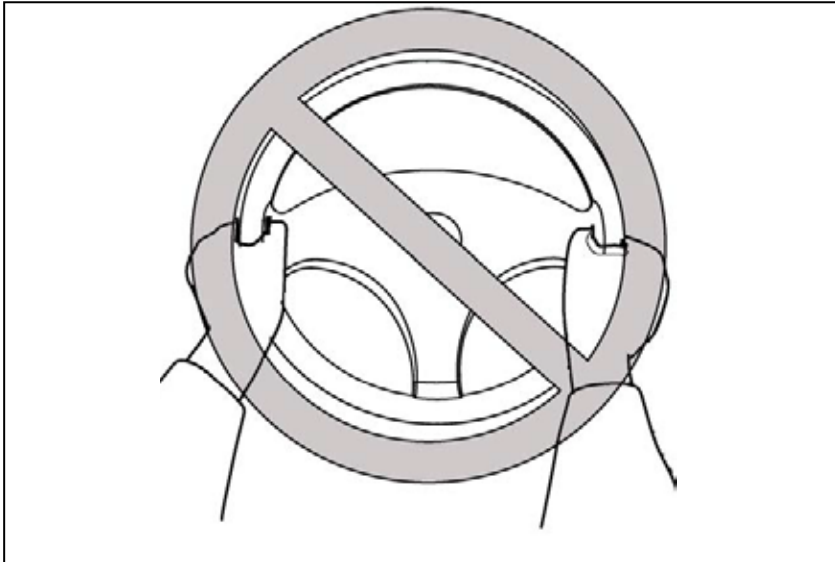

### **BRAKING**

Braking ability is affected by the type of terrain. In most cases, gradually application of the brakes is more effective than abrupt braking, particularly on loose surfaces like gravel. Always allow for greater braking distance on rough, loose, or slippery surfaces.



### **WARNING**

#### **POTENTIAL HAZARD**

Operating on excessively steep hills.

#### **WHAT CAN HAPPEN**

The vehicle can overturn more easily on extremely steep hills than on level surfaces or small hills.

#### **HOW TO AVOID THE HAZARD**

Never operate your vehicle on hills too steep for it or your abilities. Never operate vehicles on hills steeper than 15%. Do not drive across the face of a hill. Go straight up the hill. Practice on smaller hills before attempting large hills.

## 10. DRIVING YOUR VEHICLE

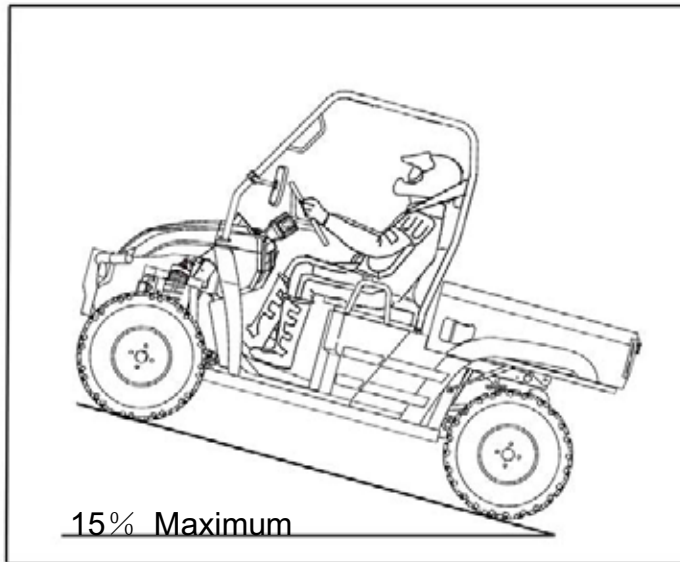

Go as slowly as possible. If you are starting to go too fast, apply the brakes gently. Avoid sudden application of the brakes, which could cause the vehicle to start sliding. If you are sliding or skidding, try to steer in the direction the vehicle is sliding to help you regain control. If you must turn on the hill to avoid an obstacle, do so slowly and carefully. If the vehicle starts to tip, gradually steer in the downhill direction if there are no obstacles in your path. As you regain proper balance, gradually steer again in the direction you want to go.



### **WARNING**

#### **POTENTIAL HAZARD**

Try to stop the tipping vehicle with your arm or leg.

#### **WHAT CAN HAPPEN**

You could be severely injured. You could suffer a crushed hand, arm, leg, or foot,

#### **HOW TO AVOID THE HAZARD**

You must keep your arms and legs inside the vehicle until it has stopped moving.

As with any off-road-capable vehicle, there is a risk of tip over or rollover under certain conditions. Uneven terrain or slopes which pitch

## 10. DRIVING YOUR VEHICLE

---

the vehicle sideways, turning too fast or sharp, or a combination of conditions increase the risk of tip over.

If you are in a situation where the vehicle is tipping over, do not put your arm or/ and leg outside the vehicle, do not try to stop tipping with your arm or leg. You could be severely injured. You could suffer a crushed hand, arm, leg, or foot, if part of your body is caught underneath the vehicle.

---



### WARNING

#### POTENTIAL HAZARD

Operating this vehicle through deep or fast-flowing water.

#### WHAT CAN HAPPEN

Loss of control, which could result in an accident including overturn, which could increase the risk of drowning.

#### HOW TO AVOID THE HAZARD

Never operate this vehicle in fast flowing water or in water deeper than 200 mm (8 in). Remember that wet brakes may have reduced stopping ability. Test your brakes after leaving water. If necessary, apply them several times to let friction dry out the linings.



### WARNING

#### POTENTIAL HAZARD

Improperly operating over obstacles

#### WHAT CAN HAPPEN

Could cause loss of control or a collision. Could cause the vehicle to overturn.

#### HOW TO AVOID THE HAZARD

---

Before operating in a new area, check for obstacles. Use extreme caution when operating over large obstacles, such as large rocks or fallen trees.

## 10. DRIVING YOUR VEHICLE

---

### PARKING

When parking, stop the **motor** and shift the drive select lever into the neutral position. Apply the parking brake to help prevent the vehicle from rolling.

#### Parking on a slope

1. Apply the brakes.
2. Set the park brake.
3. Place the direction selector in neutral.
4. Turn the key off.
5. Block the rear wheels on the downhill side.



### WARNING

#### POTENTIAL HAZARD

Parking on a hill or other incline.

#### WHAT CAN HAPPEN

The vehicle could roll out of control, increasing the chance of an accident.

#### HOW TO AVOID THE HAZARD

Avoid parking on hills or other inclines. If you must park on an incline, apply the parking brake, and block the front and rear wheels with rocks or other objects. Do not park the vehicle at all on hills that are so steep you could not walk up them easily.

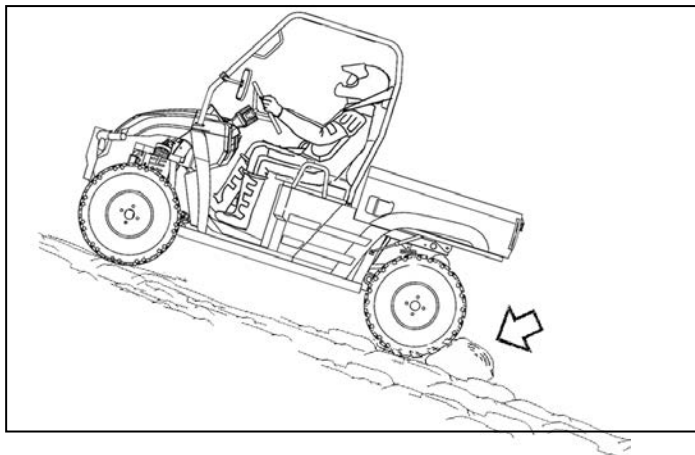



## 11. BATTERY



### WARNING

Whenever removing the battery, disconnect the negative (black) cable first. When reinstalling the battery, connect the negative (black) cable last or an explosive situation could result causing serious injury or death.



### WARNING

Battery electrolyte is poisonous. It contains sulfuric acid. Serious burns can result from contact with skin, eyes or clothing. Antidote:

**External:** Flush with water.

**Internal:** Drink large quantities of water or milk. Follow with milk of magnesia, beaten egg, or vegetable oil. Call physician immediately.

**Eyes:** Flush with water for 15minutes and get prompt medical attention. Batteries produce explosive gases. Keep sparks, flame, cigarettes, etc. away. Ventilate when charging or using in an enclosed space. Always shield eyes when working near batteries. **KEEP OUT OF REACH OF CHILDREN.**

### Battery Removal

1. Disconnect hold down straps holding the electrical box and battery in position and remove battery cover.
2. Disconnect the black (negative) battery cable first.
3. Disconnect the red(positive) battery cable next.
4. Lift the battery out of the CUV, being careful not to tip it sideways and spill electrolyte.



### CAUTION

If electrolyte spills, immediately wash it off with a solution of one tablespoon baking soda and one cup water to prevent damage to the CUV.

# 11. BATTERY

---

## Battery Installation and Connections



### WARNING

To avoid the possibility of explosion, always connect battery cables in the order specified. Red (positive) cable first; black (negative) cable last. An exploding battery can cause serious injury or death.

---



### WARNING

Battery terminals and connections should be kept free of corrosion. If cleaning is necessary, remove the corrosion with a stiff wire brush. Wash with a solution of one tablespoon baking soda and one cup water. Rinse well with tap water and dry off with clean rags. Coat the terminals with dielectric grease or petroleum jelly. Be careful not to allow cleaning solution or tap water into the battery.

---

1. Set the battery in its holder.
2. First connect and tighten the red (positive) cable.
3. Second connect and tighten the black (negative) cable.
4. Reinstall battery cover and attach the hold down strap.
5. Verify that cables are properly routed.

#### NOTE:

- When you CUV is placed in storage for one months or more, the battery should be removed, charged to proper level, and stored in a cool dry place.
- Before reusing, take the battery to your dealer for testing and recharging.

Power plug leads may need to be bent down so that battery cover may be installed.

- When installing a new battery, make certain it is fully charged prior to it is initial use. Using a new battery that has not been fully charged can damage the battery resulting in a shorter life of the battery, It can also hinder vehicle performance.

## 11. BATTERY

### Battery Conditioning

New batteries cannot initially hold all of their capacity. The approximate capacity of the battery pack increases as the number of charge cycles increases.

# of Charge Cycles:	New	15	30	45
Percent of Full Capacity:	80%	90%	95%	100%

### Ambient Temperature Implications on Batteries

1. Battery range decreases as ambient temperature decreases. This can affect the range by up to 30%.
2. Batteries discharge when left uncharged. They can discharge up to 13% per month (higher rates in warmer climates) with the key off and much faster if the key is left on.
3. Batteries can freeze if left uncharged at low ambient temperatures.

Percent Charged:	100%	50%	0%
Approximate Freezing Point:	(-51° C)	(-18° C)	(-4° C)

## FEATURES AND CONTROLS

### Main Power Connector

**NOTICE:** Damage to electrical connections and components will occur if they are unplugged before the main power connector is disconnected. Always disconnect the main power connector before servicing or unplugging any electrical components.



### WARNING

Insulate any tools used within the battery area to prevent sparks or battery explosion caused by shorting the battery terminals or wiring. Remove the batteries, or cover the exposed terminals with an insulating material.

### Charge Status Indicator

When charging the batteries, the charge status indicator light flashes and changes color to indicate the status of the charge. Refer to the

## 11. BATTERY

table below.

Color	Indication	Code Definition
Green	Slow Flash	Charge is complete,
Yellow	Slow Flash	70%~90%
Red	Slow Flash	Less than 70%



### CAUTION

Your CUV is equipped with a 100Ah Battery. This may not be sufficient to provide power for optional equipment. When installing optional equipment please upgrade your battery as necessary. See your dealer for the proper battery.

## FEATURES AND CONTROLS

### Batteries

This vehicle is equipped with five 12-volt batteries that supply the power needed to operate the vehicle. The batteries are located under the seat.

Always observe all battery safety warnings and safe handling procedures as outlined on vehicle safety labels and in this manual.

#### Battery Handling Precautions

- Always keep battery terminals and connections clean and free of corrosion at all times.
- Always maintain a full charge on the batteries. For best battery life, avoid discharging the batteries more than 80%.
- Make sure new batteries are fully charged before using.
- New deep cycle batteries need to be cycled several times before reaching full capacity (50- 125 cycles, depending on type). Capacity will be limited during this time.
- Make sure vent caps are installed properly and securely during vehicle operation and battery charging.
- Recharge batteries fully at the end of each day the vehicle is operated, allowing adequate time for the charger to complete its charge cycle. The batteries in this vehicle do not have a "memory effect". Frequent charging will extend their life.

## 11. BATTERY

---

- Avoid charging at temperatures above 49°C.ambient air temperature. Closed, unvented storage buildings often exceed this temperature when exposed to direct sunlight.
- Never connect an auxiliary battery to the factory-installed DC-to-DC converter. If more than 10 amps are needed for accessories, always install the **producer**-approved auxiliary accessory battery kit.
- Never connect a 12-volt accessory directly to the batteries. Always connect any powered accessory to a 12-volt auxiliary outlet or terminal board.
- Never connect jumper cables to any of the batteries of this vehicle.
- Use only **insulated** tools when working in the battery compartment.

### Batteries

#### Battery Charging

When not in use, park the vehicle and connect the battery charger.



### WARNING

Failure to provide adequate ventilation while charging batteries can result in an explosion. Hydrogen gas is emitted during charging and will rise and accumulate at the ceiling. Always ensure a minimum of five (5) air changes per hour in the charging area. Never charge the batteries in an area subject to a flame or spark, including areas containing gas or propane water heaters and furnaces. Do not smoke in the charging area.

Always follow these precautions when charging the batteries:

1. Position the vehicle on a level surface.
2. Make sure the charging area is well ventilated.
3. Make sure the key is off.
4. Remove any vehicle covers and open any door enclosures or zippers.

Tip: If the charger turns off due to an overheated condition (thermal cutback), remove the seat to improve air flow. Reset the charger (interrupt AC power for 15 seconds).

## 11. BATTERY

---

5. Always use an extension cord with a minimum rating of 20 amps.
6. Inspect the charging cord and extension cord for cracks, loose connections and frayed wiring. Replace any damaged components promptly.
7. Always connect the extension cord to the charge receptacle on the vehicle first, then plug the cord into a wall receptacle.
8. Make sure the charger uses a dedicated circuit to prevent overloading. If charging multiple vehicles, each vehicle should use a dedicated circuit.

Tip: After the batteries have fully recharged, the battery charger will automatically cycle in and out of the trickle charge mode to maintain the charge.

9. When disconnecting the charger, always disconnect the extension cord from the wall receptacle first, then disconnect the cord from the vehicle's charge receptacle.

### Battery Inspections

Inspect battery terminal connections monthly. Clean batteries as recommended. Using an insulated wrench, torque bolts to 8 ft. lbs. (11 Nm). If your vehicle is equipped with sealed batteries, no other maintenance is required.

### Battery Access

To access the batteries, remove the seat. Remove the storage tray (if equipped).

**NOTICE:** Before removing the seat to access the batteries, make sure any wire or metal items (including seat belt latches, if equipped) remain clear of the battery compartment to avoid causing a short circuit to the electrical system.

## 12. MAINTENANCE

---

### BATTERIES:

#### WARNING

Battery posts, terminals and related components contain lead and lead compounds, chemicals known to cause cancer and reproductive harm. Always wash your hands after touching or handling or handling the batteries.

#### WARNING

Charging a damaged battery can result in serious injury. Never attempt to charge a frozen or bulging battery. Discard the battery appropriately and install a new battery.

#### WARNING

Improperly connecting or disconnecting battery cables can result in an explosion and cause serious injury or death.

#### WARNING

Battery electrolyte is poisonous. It contains sulfuric acid. Serious burns can result from contact with skin, eyes or clothing.

Antidote:

**External:** Flush with water.

**Internal:** Drink large quantities of water or milk. Follow with milk of magnesia, beaten egg, or vegetable oil. Call physician immediately.

**Eyes:** Flush with water for 15 minutes and get prompt medical attention.

Batteries produce explosive gases. Keep sparks, flame, cigarettes, etc. Away. Ventilate when charging or using in an enclosed space. Always shield eyes when working near batteries. **KEEP OUT OF REACH OF CHILDREN.**

### BATTERIES:

#### Battery Charging

When not in use, park the vehicle and connect the battery charger. The battery charge receptacle is located on the left side panel below the driver's seat.

**Warning!** Failure to provide adequate ventilation while charging batteries can result in an explosion. Hydrogen gas is emitted during charging and will rise and accumulate at the ceiling. Always ensure a minimum of (5) air changes per hour in the charging area. Never charge

## 12. MAINTENANCE

---

the batteries in an area subject to a flame or spark, including areas containing gas or propane water heaters and furnaces. Do not smoke in the charging area.

Always follow these precautions when charging the batteries:

- 1.Position the vehicle on a level surface.
- 2.Make sure the charging area is well ventilated.
- 3.Make sure the key is off.
- 4.Remove any vehicle covers and open any door enclosures or zippers.  
**Tip:** If the charger turns off due to an overheated condition (thermal cutback), remove the seat to improve air flow. Reset the charger (interrupt AC power for 15 seconds).
- 5.Always use a extension cord with a minimum rating of 20 amps.
- 6.Inspect the charging cord and extension cord for cracks, loose connections and frayed wiring. Replace any damaged components promptly.
- 7.Always connect the extension cord to the charge receptacle on the vehicle first, then plug the cord into a wall receptacle.
- 8.Make sure the charger uses a dedicated circuit to prevent overloading. If charging multiple vehicles,each vehicle should use a dedicated circuit.

**TIP:** After the batteries have fully recharged, the battery charger will automatically cycle in and out of the trickle charge mode to maintain the charge.

- 9.When disconnecting the charger, always disconnect the extension cord from the wall receptacle first, then disconnect the cord from the vehicle's charge receptacle.

### **Battery Inspections**

Inspect battery terminal connections monthly. Clean batteries as recommended. Using an insulated wrench, torque bolts to 8 ft.lbs. (11Nm).

If your vehicle is equipped with sealed batteries, no other maintenance is required.

### **Battery Access**

To access the batteries, remove the seat. See page 25. Remove the storage tray (if equipped).

**NOTICE:** Before removing the seat to access the batteries, make sure any wire or metal items (including seat belt latches, if equipped) remain clear of the battery compartment to avoid causing a short circuit to the electrical system.



## 12. MAINTENANCE

---

### BATTERIES:

#### Battery Cleaning

Always keep battery terminals and connections free of corrosion. To clean, remove corrosion with a stiff wire brush. Wash with a solution of one tablespoon baking soda and one cup water. Rinse well tap water and dry off with clean shop towels. Coat battery terminals with dielectric grease or petroleum jelly.

**NOTICE:** Do not allow cleaning solution or tap water to enter the batteries.

#### Battery replacement

With proper care and maintenance as outlined in this owner's manual, battery life could be extended up to four years or longer, depending on the amount of use. When battery replacement is necessary, please see your authorized **vehicle** dealer.

**WARNING!** Hanging batteries and electrical components improperly can result in serious injury or death. Do not attempt to remove batteries or battery cables. Always see your dealer for battery-related service.

#### Battery disposal

Lead-acid batteries are recyclable. Return whole scarp batteries to a distributor, manufacturer or lead smelter for recycling. For neutralized spills, place residue in acid-resistant containers with absorbent material, sand or earth and dispose of in accordance with local, state and federal regulations for acid and lead compounds. Contact local and/or state environmental officials regarding disposal information. You can also contact **vehicle** Customer Service for information. See page 1.

#### Battery Fluid (Conventional Batteries)

A poorly maintained battery will deteriorate rapidly. Check the battery fluid level often. Add only distilled water. Tap water contains minerals that are harmful to a battery.

Unless the plates are exposed before charging, distilled water should be added to a battery after charging. If the plates are exposed, add water to about 1/8 inch (3 mm) above the plates, then charge. Check the fluid level again after charging. Maintain the fluid level 1/4 inch (6 mm) below the bottom of the fill well in the cell cover. Do not overfill.

If your vehicle is equipped with a battery watering system, please refer to watering system instruction manual for proper use.

## 12. MAINTENANCE

---



### CAUTION

Due to the nature of the adjustments marked with a **D** on the following chart, it is recommended that service be performed by an authorized dealer.

---

1. More often under severe use, such as dirty or wet conditions to purge water or dirt contamination from grease fittings and other critical components.

### PERIODIC MAINTENANCE SCHEDULE

Careful periodic maintenance will help keep your vehicle in the safest, most reliable condition. Inspection, adjustment and lubrication intervals of important components are explained in the following chart on the following pages.

#### NOTE:

Maintenance intervals are based upon average riding conditions and an average vehicle speed of approximately 16 km/ 10 miles per hour.

However, keep in mind that if the vehicle isn't used for a long period of time, the month maintenance intervals should be followed.

Vehicles subjected to severe use, such as operation in wet or dusty areas, should be inspected and serviced more frequently.

Inspect, clean, lubricate, adjust or replace parts as necessary.

#### NOTE:

Inspection may reveal the need for replacement parts. Always use genuine parts available from your dealer.

Service and adjustments are critical. If you are not familiar with safe service and adjustment procedures, have a qualified dealer perform these operations.

## 12. MAINTENANCE

	Item	Hours	When	Remarks
●	Rear Gear case Oil	100 hrs	Monthly	Check monthly and change annually
●	Transmission Oil	20 hrs	Monthly	Check monthly and change annually
●	Brake System	Pre-ride	Pre-ride	Pre-ride inspection item
	Accelerator pedal	Pre-ride	Pre-ride	Inspect –adjust, lubricate, replace if necessary; pre-ride inspection item
	Battery power System	Pre-ride	Pre-ride	Check Meter battery indicator
●	Tires	Pre-ride	Pre-ride	Inspect daily, pre-ride inspection item
●	Front and Rear Wheels/ Hubs	Pre-ride	Pre-ride	Pre-ride inspection item
●	Steering	Pre-ride	Pre-ride	Inspect daily, lubricate
D	Wheels bearings	10 hrs	Monthly	Check for looseness/ damage. Replace if damaged.
	Frame nuts, bolts fasteners	Pre-ride	Pre-ride	Pre-ride inspection item
●	Motor controller	Daily	Daily	Inspect-Clean
●	Battery charger	Daily	Daily	Inspect-Clean
●	DC converter	Daily	Daily	Inspect-Clean
	Headlamp Inspection	Daily	Daily	Check operation daily; apply dielectric grease to connector when replaced
	Tail/ indicator lamp inspection	Daily	Daily	Check operation daily; apply dielectric grease to socket when replaced
	Battery	20 hrs	Monthly	Check/clean Terminals; check fluid level
D	Brake pad wear	10 hrs	Monthly	Inspect periodically
●	General Lubrication	50 hrs	3 months	Lubricate all fittings, pivots, cables, etc.
D	Throttle Cable/ Accelerator pedal	20 hrs	monthly	Inspect –adjust, lubricate, replace if necessary; pre-ride inspection item

## 12. MAINTENANCE

	Item	Hours	When	Remarks
D	Steering system	50 hrs	6 months	Check operation and for looseness, worn, damage, binding feeling / Adjust, repair, Replace if necessary. Check toe alignment /Adjust if necessary.
D	Toe adjustment	As required	As required	Periodic inspection, adjust when parts are replaced
●	Rear Axle	50 hrs	6 months	Inspect bearings, Lube
●	Front Suspension	50 hrs	6 months	Inspect-lubricate, tighten fasteners
●	Rear Suspension	50 hrs	6 months	Inspect, tighten fasteners
●	Wiring	100hrs	12 months	Inspect for wear, routing, security; apply dielectric grease to connectors subjected to water, mud, etc.
D	Shift selector box (D/N /R)	200 hrs	24 months	Change grease every two years
D	Brake fluid	200 hrs	24 months	Change every two years
	Headlight Aim	As required	As required	Adjust if necessary

(1) Change Motor controller after six years or 100000km.

(2) Change Battery charger after six years or 100000km.

(3) Change DC converter after six years or 100000km.

## 12. MAINTENANCE

### LUBRICATION RECOMMENDATIONS

	Item	Lube Rec	Method	Frequency
1	Rear Gear case oil	SAE GL-4 85W/90	See "12.MAINTENANCE/ Rear Gear case Lubrication"	Change annually or at 100 hours
2	Transmission case Oil	SAE GL-4 85W/90	See "12.MAINTENANCE/ Transmission case Lubrication"	Change annually or at 100 hours
3	Steering system	Grease	Lubricate the pivoting and sliding parts	Every 3 months or 50 hours
4	Tie rods	Grease	Grease	Semi-annually
5	.Front Wheel bearings	Inspect	Inspect and replace bearings if necessary	Semi-annually
6	Ball joints	Grease	Inspect, Locate fittings and Grease, or replace it if necessary	Semi-annually
7	Front/Rear A-arm pivot Shaft	Grease	Locate fitting on pivot shaft and grease with grease gun	Every 3 months or 50 hours

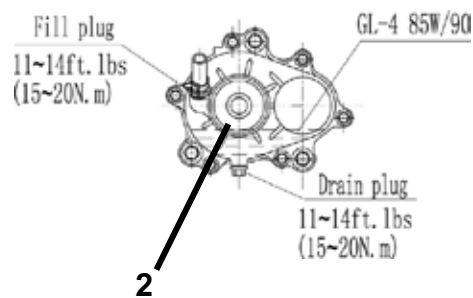
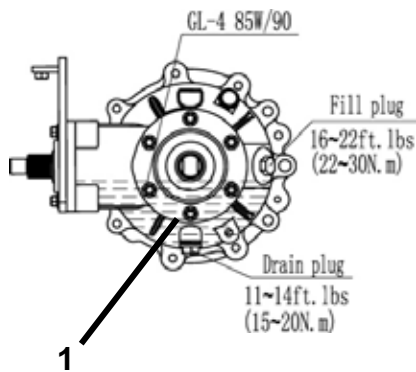

## 12. MAINTENANCE

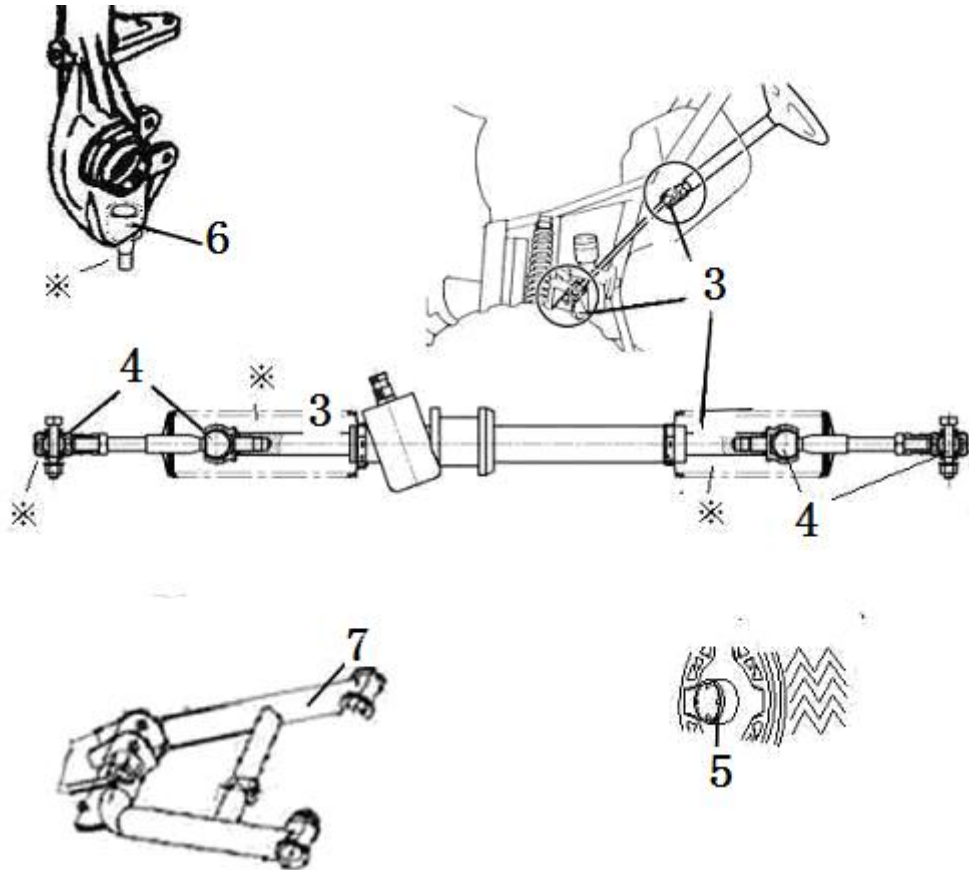

※---Check the protective boots for holes or tears. If any damage is found, have them replaced by an authorized dealer.

### NOTE:

1. More often under severe use, such as wet or dusty condition.
2. Grease: Light weight lithium-soap grease.
3. Grease M: molybdenum disulfide( $\text{MoS}_2$ ) grease(water resistant).
4. \*When suspension action becomes stiff or after washing.
5. Hours are based on 10 mph(16Km/h) average.

## 12. MAINTENANCE

---

### PERIODIC MAINTENANCE RECORD

Use the following chart to record periodic maintenance work:

Maintenance Interval Performed	Servicing Date	Servicing Dealer or Person	Remarks
First 5 Hrs			
10 Hrs			
15 Hrs			
20 Hrs			
25 Hrs			
50 Hrs			
75 Hrs			
100 Hrs			

## 12. MAINTENANCE

---

### Rear Gear case Lubrication



#### CAUTION

Be sure no foreign material enters the rear gear case.

With the electric UTV on a level surface, remove the fill plug and visually inspect the lubricant level through the fill hole. Lubricant should be kept even with the center of the drill point approximately below the top of the fill hole.

**NOTE:** Do not add lubricant to the bottom of the fill plug threads. The correct gear case lubricant to use is SAE GL-4 85W/90 Weight Gear Lube.

### Oil Changing Procedure

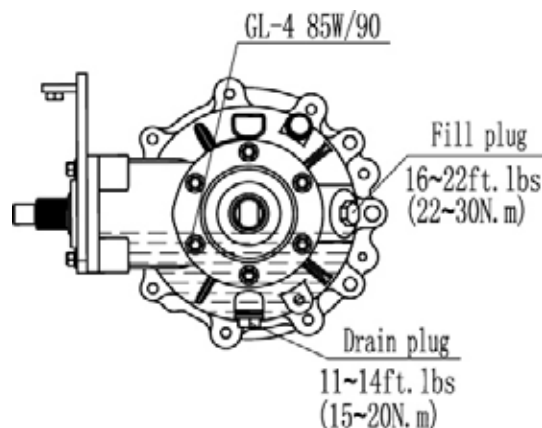

1. Remove drain plug. Catch and discard used oil properly.
2. Clean and reinstall the drain plug with a new sealing washer. Torque drain plug to 11~14 ft. lbs. (15~20N.m)



## 12. MAINTENANCE

3. Remove fill plug and add 550ml of SAE GL-4 85W/90 Weight Gear Lubricant and inspect oil level. Oil level should be kept even with the center of the drill point (approximately below the top of the fill hole).
4. Reinstall the fill plug. Torque Fill plug to 16~22 ft. lbs. (22~30N.m)
5. Check for leaks.

### Transmission case Lubrication



#### CAUTION

Be sure no foreign material enters the transmission gear case. With the electric UTV on a level surface, remove the fill plug and inspect the lubricant level through the fill hole. We recommend that you use a syringe to add gear oil. (Syringe: the range of at least 60 ml.)

**NOTE:** Do not add lubricant to the bottom of the fill plug threads. The correct gear case lubricant to use is SAE GL-4 85W/90 Weight Gear Lube.

### Oil Changing Procedure

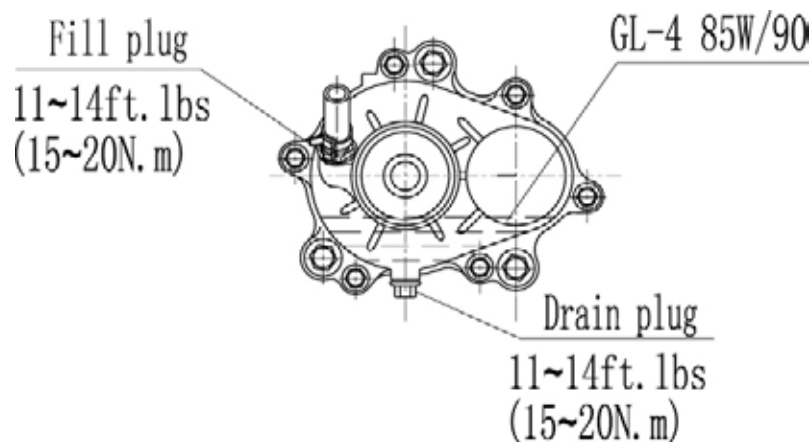

1. Remove drain plug. Catch and discard used oil properly.

## 12. MAINTENANCE

2. Clean and reinstall the drain plug with a new sealing washer. Torque drain plug to 11~14 ft. lbs. (15~20N.m).
3. Remove fill plug and add 50ml of SAE GL-4 85W/90 Weight Gear Lubricant and inspect oil level.
4. Reinstall the fill plug. Torque Fill plug to 16~22 ft. lbs. (22~30N.m).
5. Check for leaks.

### WHEEL NUT TORQUE SPECIFICATIONS

Bolt Size		Specification	
Front	M12X1.25	69Ft.Lbs	95N.m
Rear	M12X1.25	69Ft.Lbs	95N.m

**NOTE: All nuts that have a cotter pin installed must be serviced by an authorized Dealer.**

#### Front Wheel Hub Tightening

Front wheel bearing tightness and spindle nut retention are critical component operations. Service work must be performed by an authorized dealer.

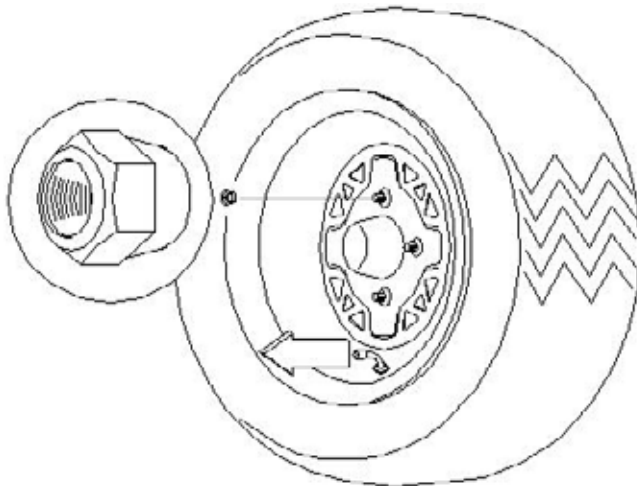

**Front**

**Rear**

**Tapered nuts: install with tapered side against wheel**

#### AXLE BOOTS

- Rear Prop Shaft Boots,

## 12. MAINTENANCE

- Front Axle (CV Joints, 4x4 model) Boots,  
Check the protective boots for holes or tears. If any damage is found, have them replaced by an authorized dealer.

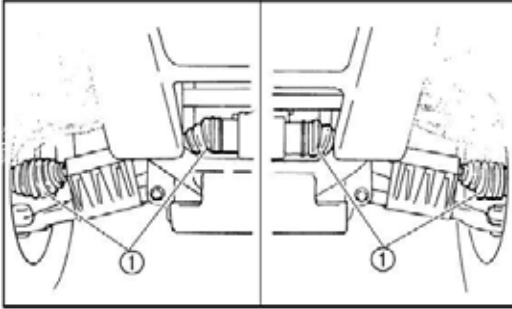

1. Front axle boot (x: 2 each side)

### REAR SPRING ADJUSTMENT

The rear shock absorber spring is adjusted by rotating the adjuster in the direction required to increase or decrease spring tension.

Rear Spring  
Adjustment

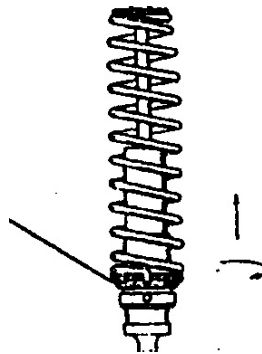

### STEERING

#### Steering Inspection

The steering assembly of the machine should be checked periodically for loose nuts and bolts, worn tie rod ends, worn boots, and damage. Checking routing of all cables, hoses, and wiring to be sure the steering mechanism is not restricted or limited. If any found, have your dealer repair them before riding your vehicle.

The steering assembly should be also checked periodically for free operation, steering should move freely through entire range of travel without binding. Park on level ground. Turn the steering wheel right and left. Check for excessive free play, abnormal noises, or a rough feeling.

## 12. MAINTENANCE

Have an authorized dealer repair as necessary for proper operation.

### Lubricate the pivoting parts.

Recommended lubricant:  
Lithium-soap-based grease

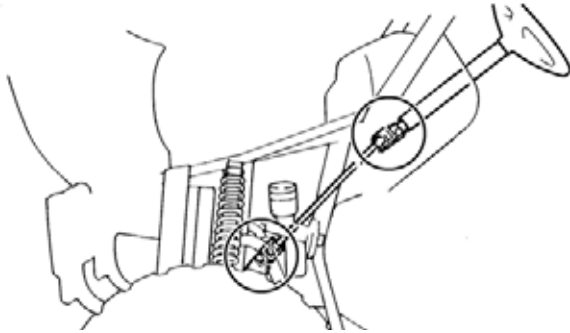

### CAMBER AND CASTER

The camber and caster are non-adjustable.

### TOE ALIGNMENT CHECK



#### WARNING

Do not attempt to adjust the tie rod for toe alignment. Severe injury or death can result from improper adjustment. Contact your dealer. He/she has the training and tools to Make these adjustment.

The recommended toe alignment is

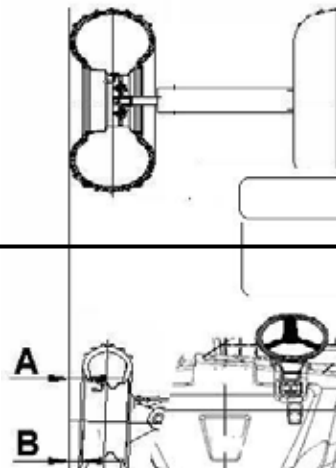

12- 14

## 12. MAINTENANCE

1/8" to 1/4" (3 to 6mm) toe out.

1. Set the steering wheel in a straight ahead position and hold them in this position.
2. Measure A and B, A minus B should be 1/16" to 1/8" (1.5 to 3mm).
3. If this measurement needs to be adjusted, contact your dealer for service.



### WARNING

If the tie rod is positioned incorrectly or adjusted incorrectly, it will not pivot, may break, and may separate. Severe injury or death can result

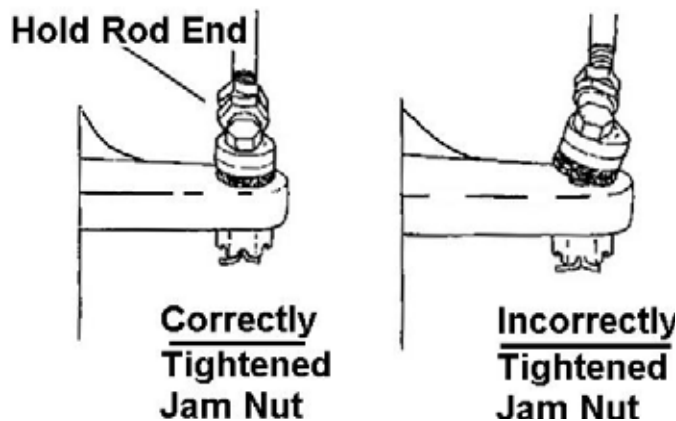

### BRAKES

#### Front brake



### WARNING

Once a bottle of brake fluid is opened, use what is necessary and discard the rest. Do not store or use a partial bottle of brake fluid. Brake fluid is hygroscopic, meaning it rapidly absorbs moisture from the air. This causes the boiling temperature of the brake fluid to drop, which can lead to early brake fade and the possibility of serious injury.

The front brake is hydraulic disc brakes which is depressing the brake pedal. These brakes are self-adjusting and require no adjustment.

## 12. MAINTENANCE

The following checks are recommended to keep the brake system in good operating condition. How often they need checking depends upon the type of driving that has been done.

- Keep fluid level in the master cylinder reservoirs as described see "7.Control and part functions". Normal functioning of the diaphragm is to extend into the reservoir as fluid level drops. If the fluid level is low and the diaphragm is not extended, a leak is indicated and the diaphragm should be replaced. Always fill the reservoir as indicated whenever the cover is loosened or removed to insure proper diaphragm operation. Use DOT 3 brake fluid.

- Check brake system for fluid leaks.
- Check brake for excessive travel or spongy feel.
- Check friction pads for wear, damage and loosened.
- Check security and surface condition of the disc.
- Pads should be changed when friction material is worn to  $3/64"$ (1mm).(A)

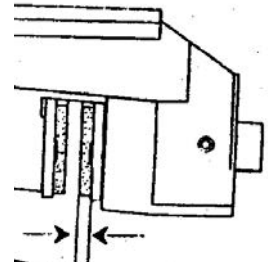

### Rear Brake

- The rear brake is a hydraulic disc type brake which is activated by the same pedal which activates the front brake system is self adjusting and requires no maintenance other than periodic checks of the pads for wear
- Pads should be changed when the friction material is worn to  $3/64"$ (1mm).
- Inspect the brake disc and pad wear surface for excessive wear.

### Checking the brake fluid level

Insufficient brake fluid may let air enter the brake system, possibly causing the brakes to become ineffective. Before riding, check that the brake fluid is above



## 12. MAINTENANCE

the minimum level mark and replenish if necessary. A low brake fluid level may indicate worn brake pads and/or brake system leakage. If the brake fluid level is low, be sure to check the brake pads for wear and the brake system for leakage. The brake fluid reservoir is located under the hood.

- When checking the fluid level, make sure the top of the brake fluid reservoir is level.
- Use only the recommended quality brake fluid. Otherwise, the rubber seals may deteriorate, causing leakage and poor braking performance.

Recommended brake fluid: DOT 3

- Refill with the same type of brake fluid. Mixing fluids may result in a harmful chemical reaction and lead to poor braking performance.
- Be careful that water does not enter the brake fluid reservoir when refilling. Water will significantly lower the boiling point of the fluid and may result in vapor lock.
- Brake fluid may deteriorate painted surfaces or plastic parts. Always clean up spilled fluid immediately.
- Have an authorized dealer inspect the brake system if the brake fluid level goes down.

### Brake light Switch Adjustment

The brake lights switch, which is activated by the parking pedal, is properly adjusted when the brake light comes on just before braking takes effect. If necessary, adjust the brake lights switch as follows.

1. Open the hood. (See 7.

#### CONTROL AND PARTS

FUNCTIONS in this manual for hood opening and closing procedures.)

2. Turn the adjusting nut ① in or out to make the light come on properly, then lock the lock nut ②.

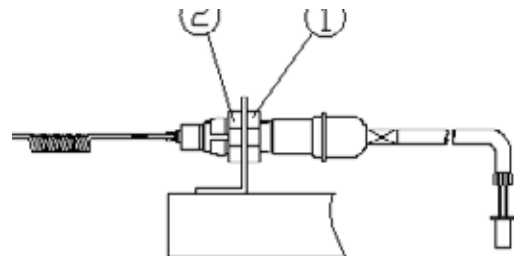

### Brake pedal and accelerator pedal lubrication

Lubricate the pivoting parts.

## 12. MAINTENANCE

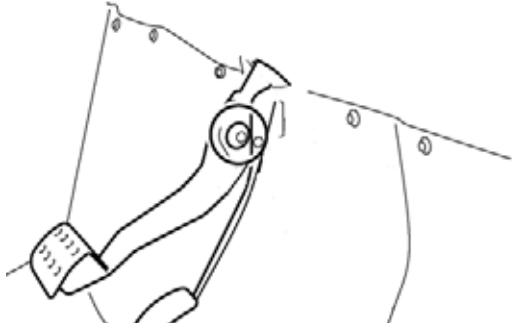

Recommended lubricant:  
Lithium-soap-based  
grease (all-purpose  
grease)

### PARKING BRAKE

#### Checking

Although the parking brake has been adjusted at the factory, the brake should be checked for proper operation. The mechanical brake must be maintained to be fully functional.

1. With the **motor** off, apply the parking brake lever and attempt to move the CUV.
2. If the rear wheels are locked, it is adjusted properly.
3. If the wheels are not locked, it must be adjusted.
4. The maximum free play is equal to one click of the parking brake lever. If necessary, adjust the free play as follows.

#### Adjusting

**To adjust (set up) the mechanical parking brake, use the following procedure**

**Note:** The adjusting on the caliper is for the wear out of the pads.

1. With the **motor** off, loosen the adjuster on the lever.
2. Loosen the jam nut of the adjuster on the caliper.
3. Turn the adjuster (bolt) CW (clockwise) by hand till the pad touch the brake disc, turn the adjuster bolt CCW (counterclockwise) by 1/4 to one turn for 10 to 20mm free play at the end of the parking lever.
4. Tighten the jam nuts securely against the adjusters.
5. Make sure the rear wheels turns freely without dragging.
6. Turn the adjuster (the one on the lever) and apply the lever. While adjusting, it is important you apply the lever back and forth for operation, free play and the locking of the parking position.
7. Make sure the rear wheels turns freely without dragging and parking brake works properly.



## 12. MAINTENANCE



### CAUTION

Don't over tighten the adjuster. The maximum free play is equal to one click of the parking brake lever.

.8. Field test for parking. It must be capable of holding the laden CUV stationary on an 18% up and down gradient.

A temporary adjusting can also be done to the brake cable on the parking lever side by turn the adjuster (nut) directly. But the adjust range is limited. Always do the **procedure 1 to 8** when necessary.



#### Parking Brake Indicator (light) Switch Adjustment

The parking indicator switch, which is activated by the parking lever, is properly adjusted when the indicator light comes on just before braking takes effect. If necessary, adjust the parking indicator switch as follows.

1. Lift the cargo bed. (See 7. CONTROL AND PARTS FUNCTIONS in this manual for bed lifting and lowering.)

2. Turn the adjusting nut ① in or out to make the light come on properly, then lock the lock nut ②.

(all-purpose grease)

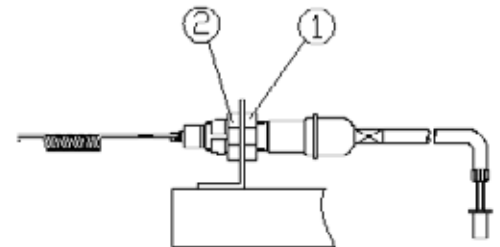
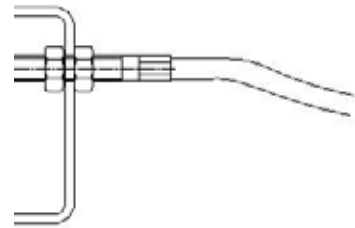

## WHEELS AND TIRES



### WARNING

## 12. MAINTENANCE

Operating your CUV with worn tires, improperly inflated tires, non-standard tires or improperly installed tire will affect vehicle handling which could cause an accident resulting in serious injury or death. Follow the safeguards listed below to prevent this type of situation.

### Important Safeguards

Maintain proper tire pressure according to charts below. Improper tire inflation may affect CUV maneuverability.

Do not use improper tires. The use of non-standard size or type tires may affect CUV handling.

Make certain the wheels are installed properly. If wheels are improperly installed it could affect vehicle handling and tire wear.

Tire Pressure	
front	rear
see detail on the mark of sidewall	see detail on the mark of sidewall

### Wheel Removal Procedure

1. Stop the **motor**, place the transmission in gear and lock the parking brake.
2. Loosen the wheel nuts slightly.
3. Elevate the side of the vehicle by placing a suitable stand under the footrest frame.
4. Remove the wheel nuts and remove the wheel.

### Wheel Installation

1. With the transmission in gear and the parking brake locked, place the wheel in the correct position on the wheel hub. Be sure the valve stem is toward the outside and rotation arrows on the tire point toward forward rotation.
2. Attach the wheel nuts and finger tighten them.
3. Lower the vehicle to the ground.
4. Securely tighten the wheel nuts according to the chart found in "**12.MAINTENANCE/ Wheel Nut Torque**".

## 12. MAINTENANCE

---

### Tire Inspection

When replacing a tire always use original equipment size and type.

### Tire Tread Depth

Always replace tires when tread depth is worn to 1/8" (3mm) (1) or less. Please refer to your Owner's Manual for tire specifications.



## LIGHTS



### WARNING

Keep your headlights and taillights clean. Poor light while riding can result in an accident causing severe injury or death.

---



### CAUTION

Do not service while headlight is hot. Serious burns may result. Do not touch a halogen lamp with bare fingers. Oil from your skin leaves a residue, causing a hot spot which will shorten the life of the lamp.

---

## CLEANING YOUR CUV

Keeping your CUV clean will extend the life of various components.

### Washing

Never use a high pressure type car wash system, it can damage to the wheel bearings, transmission seals, body panels, brakes and warning labels, and water might enter the motor.

The best and safest way to clean your CUV is with a garden hose and a pail of mild soap and water. Use a professional type washing mitten, cleaning the upper body first and lower parts last. Rinse with water frequently and dry with a chamois to prevent water spots. **NOTE:**

## 12. MAINTENANCE

If warning labels are damaged, contact your dealer for replacement.

### Waxing

Your CUV can be waxed with any non-abrasive automotive paste wax. Avoid the use of harsh cleaners since they can scratch the body finish.



### CAUTION

Certain products, including insect repellants and chemicals, will damage plastic surfaces. Care must be taken when using these products plastic surfaces.

### STORAGE TIPS



### CAUTION

Do not start the motor during the storage period. This will disturb the protective film created by fogging.

**Cleaning**—Clean the CUV thoroughly.

**Inspect All Fluid Levels**—Inspect the following fluid levels and change if necessary: transmission; brake fluid (change every two years or as required if fluid looks dark or contaminated).

**Check and Lubricate Cables/Grease**—Inspect all cables and lubricate.

**Battery Maintenance**—Remove the battery and add distilled water as required to the proper level. Do not use tap water which may contain minerals that reduce battery life. Apply Dielectric Grease to the terminal bolts and terminals. Charge the battery.

**Storage Area/Covers**—Set tire pressure and safely support the CUV with the tires 1-2”(25-50mm) off the ground. Be sure the storage area is well ventilated. Cover the machine with a CUV cover.

NOTE: Do not use plastic or coated materials. They do not allow enough ventilation to prevent condensation, and may promote corrosion and oxidation.

### TRANSPORTING

Whenever the CUV is to be transported the following measures should be taken.

1. Turn off the power and remove the key.
2. Be certain the oil cap, and seat are installed correctly.

## **12. MAINTENANCE**

---

3. Always tie the frame of the CUV to the transporting until securely using suitable straps or rope.
4. Always place the transmission in gear and lock the parking brake.

## 13. TOOL

---

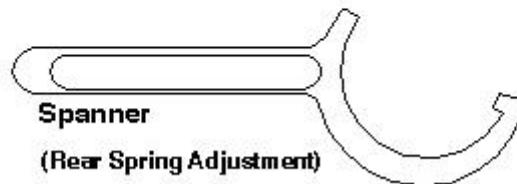
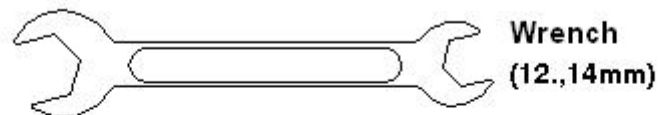
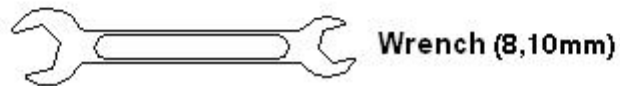
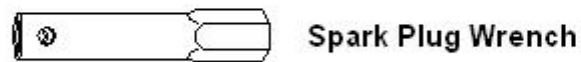
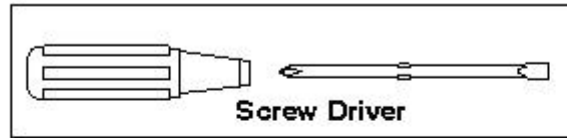

## 14. SPECIFICATION

<b>Dimensions &amp; Capacities</b>		
L X W X H	2700X1420X1870 mm	106.3x 56x 73.6 in
Seat height	850 mm	33.5 in
Wheel Base	1805 mm	71 in
Turn Radius	Outer: 4500 mm	177 in
	Inner: 3000 mm	118 in
Ground Clearance	260 mm	10.2 in
Dry Weight without battery	426kg	939lb
Cargo Bed Maximum load limit	150 kg	330 lb
Load Capacity (Combined Rider & Payload)	300 kg	660 lb
Gross Vehicle Weight (Maximum Technically Permissible Mass)	976kg	2150lb
<b>Drive System</b>		
Electric motor	60V AC Asynchronous Motor	
Front Tire	24X8-12	
Rear Tire	24X8-12	
Tire Pressure(front)	152 kPa	22 PSI
Tire Pressure(rear)	152 kPa	22 PSI
<b>Brake System</b>		
Brake	Front Brake	Two Sides Hydraulic Disc
	Rear Brake	Two Sides Hydraulic Disc
	Operation	Foot
<b>Suspension</b>		
Front	McPherson independent suspension	
Rear	Twin-A arm independent suspension	
shock absorber	Coil spring/oil damper	

## 14. SPECIFICATION

---

<b>Electrical Equipment</b>			
Battery		12V 150AH	
Head light		35W/35W x2	
Front Turn Indicator Light		21W/5W x2	
Front Position Light		12V 5W x2	
Rear Turn Indicator Light		21W/5W x2	
Rear Position Light		12V 5W x2	
Specified fuses	12V DC-OUT Fuse	10 A	In The Fuse Box
	Backup Fuse	10 A	
	Backup Fuse	15 A	
	Accessory Socket Fuse	10 A	
	Signaling Lighting System Fuse	15 A	
	Signaling System Fuse	10A	



# 15. WIRING DIAGRAM

WIRING DIAGRAM FOR LH50DU

