

Kubota

U.S.A. : **KUBOTA TRACTOR CORPORATION**
3401 Del Amo Blvd., Torrance, CA 90503, U.S.A.
Telephone : (310)370-3370
Western Division : 1175 S. Guild Ave., Lodi, CA 95240
Telephone : (209)334-9910
Central Division : 14855 FAA Blvd., Fort Worth, TX 76155
Telephone : (817)571-0900
Northern Division : 6300 at One Kubota Way, Groveport, OH 43125
Telephone : (614)835-1100
Southeast Division : 1025 Northbrook Parkway, Suwanee, GA 30024
Telephone : (770)995-8855
Canada : **KUBOTA CANADA LTD.**
5900 14th Avenue, Markham, Ontario, L3S 4K4, Canada
Telephone : (905)94-7477
France : **KUBOTA EUROPE S.A.S.**
19-25, Rue Jules Verne, Z.I. BP88, 95101 Argenteuil Cedex, France
Telephone : (33)1-3429-3434
Italy : **KUBOTA EUROPE S.A.S. Italy Branch**
Via Grandi, 29 20068 Peschiera Borrome (MI) Italy
Telephone : (39)02-51650377
Germany : **KUBOTA (DEUTSCHLAND) GmbH**
Senefelder Str. 3-5 63110 Rodgau /Nieder-Roden, Germany
Telephone : (49)6106-873-0
U.K. : **KUBOTA (U.K.) LTD.**
Dorner Road, Thame, Oxfordshire, OX9 3UN, U.K.
Telephone : (44)1844-214500
Spain : **KUBOTA ESPAÑA S.A.**
Avenida Recomba No.5, Poligono Industrial la Laguna, Leganes, 28914 (Madrid) Spain
Telephone : (34)91-638-6442
Australia : **KUBOTA TRACTOR AUSTRALIA PTY LTD.**
25-29 Permas Way, Truganina, VIC 3029, Australia
Telephone : (61)3-9394-4400
Malaysia : **SIME KUBOTA SDN. BHD.**
No.3, Jalan Sepadu 25/123 Taman Perindustrian Axis,
Sekoyen 25, 40400 Shah Alam, Selangor Darul Ehsan Malaysia
Telephone : (60)3-736-1388
Philippines : **KUBOTA PHILIPPINES, INC.**
155 Finlay Avenue, South Triangle Homes, 1103 Quezon City, Philippines
Telephone : (63)2-9201071
Taiwan : **SHIN TAIWAN AGRICULTURAL MACHINERY CO., LTD.**
16, Fengping 2nd Rd., Tainiao Shiang Kashiung 63107, Taiwan R.O.C.
Telephone : (886)7-702-2333
Indonesia : **PT KUBOTA MACHINERY INDONESIA**
Tower A at EightyEightKasablanka Lantai 16
Jalan Raya Casablanka Kav. 88, Jakarta 12870 Indonesia
Telephone : (62)21-29568-720
Thailand : **SIAM KUBOTA CORPORATION CO., LTD.**
101/19-24 Moo 20, Navanakorn Industrial Estate, Tambon Khlongnueng, Amphur Khlongluang,
Pathumthani 12120, THAILAND
Telephone : (66)2-905-3300
Korea : **KUBOTA KOREA CO., LTD.**
106-24 Mongsan-Ri, Mankyung-Up, Kimje-City, Chonrapuk-Do, KOREA
Telephone : (82)63-544-5822
India : **KUBOTA AGRICULTURAL MACHINERY INDIA PVT. LTD.**
Regus, Level 2 Altus, Olympia Tech Park, No.1 SIDCO Industrial Estate, Guindy, Chennai 600032, TN, India
Telephone : (91)44-4299-4237
Vietnam : **KUBOTA VIETNAM CO., LTD.**
Lot B-3A2-C4, My Phuoc 3 Industrial Park, Ben Cat District, Binh Duong Province, Vietnam
Telephone : (84)650-3577-507

KUBOTA Corporation

AS . E . 4 - 4 . . . AK

Code No. K7421-7121-4

OPERATOR'S MANUAL

KUBOTA *RTV-X900* UTILITY VEHICLE *RTV-X1120D*



1AYAACQAP0010

R
T
V
X
9
0
0
·
R
T
V
X
1
1
2
0
D

READ AND SAVE THIS MANUAL

Kubota



ABBREVIATION LIST

Abbreviations	Definitions
2WD	2 Wheel Drive
4WD	4 Wheel Drive
API	American Petroleum Institute
ASABE	American Society of Agricultural and Biological Engineers, USA
ASTM	American Society for Testing and Materials, USA
DIN	Deutsches Institut für Normung, GERMANY
fpm	Feet Per Minute
HST	Hydrostatic Transmission
Km/h	Kilometers Per Hour
MPH	Miles Per Hour
m/s	Meters Per Second
PTO	Power Take Off
RH/LH	Right-hand and left-hand sides are determined by facing in the direction of forward travel
ROPS	Roll-Over Protective Structures
rpm	Revolutions Per Minute
r/s	Revolutions Per Second
SAE	Society of Automotive Engineers, USA
VHT	Variable Hydro Transmission

California Proposition 65

▲ WARNING ▲

Engine exhaust, some of its constituents, certain vehicle components and fluids, contain or emit chemicals known to the State of California to cause cancer and birth defects or other reproductive harm.

IMPORTANT

The engine in this machine is equipped by the manufacture with a standard spark arrester.
It is a violation of California Public Resource Code Section 4442 to use or operate this engine on or near any forest-covered, brush-covered land, or grass-covered land unless the exhaust system is equipped with a working spark arrester meeting state laws. Other states or federal areas may have similar laws.

KUBOTA Corporation is ...

Since its inception in 1890, KUBOTA Corporation has grown to rank as one of the major firms in Japan.

To achieve this status, the company has through the years diversified the range of its products and services to a remarkable extent, until today, 19 plants and 16,000 employees produce over 1,000 different items, large and small.

All these products and all the services which accompany them, however, are unified by one central commitment. KUBOTA makes products which, taken on a national scale, are basic necessities. Products which are indispensable, products intended to help individuals and nations fulfill the potential inherent in their environment. For KUBOTA is the Basic Necessities Giant.































This potential includes water supply, food from the soil and from the sea, industrial development, architecture and construction, transportation.

Thousands of people depend on KUBOTA's know-how, technology, experience and customer service. You too can depend on KUBOTA.



UNIVERSAL SYMBOLS

As a guide to the operation of your vehicle, various universal symbols have been utilized on the instruments and controls. The symbols are shown below with an indication of their meaning.

	Safety Alert Symbol		Diesel Preheat/Glow Plugs (Low Temperature Start Aid)
	Seat Belt (2 point type)		Differential Lock
	Seat Belt (3 point type)		Differential Lock Hold
	Diesel Fuel		Lift Cylinder-Retract
	Fuel-Level		Lift Cylinder-Extend
	Hourmeter/Elapsed Operating Hours		Lift Cylinder-Float
	Engine Coolant-Temperature		Steering Wheel-Tilt Control
	Brake Fluid		Hazard Warning Lights
	Parking Brake		Headlight
	Battery Charging Condition		Audible Warning Device
	Engine Oil-Pressure		Fast
	VHT Oil-Temperature		Slow
	Turn Signal/Hazard		4-Wheel Drive-On
	Engine-Stop		Lock
	Engine-Run		Unlock
	Starter Control		

FOREWORD

You are now the proud owner of a KUBOTA Vehicle. This vehicle is a product of KUBOTA quality engineering and manufacturing. It is made of excellent materials and under a rigid quality control system. It will give you long, satisfactory service. To obtain the best use of your vehicle, please read this manual carefully. It will help you become familiar with the operation of the vehicle and contains many helpful hints about vehicle maintenance. This manual contains instructions for minor maintenance, but information about major repairs is outlined in the KUBOTA Work Shop Manual and should be performed only by a KUBOTA Dealer Technician. It is KUBOTA's policy to utilize as quickly as possible every advance in our research. The immediate use of new techniques in the manufacture of products may cause some small parts of this manual to become outdated. KUBOTA distributors and dealers will have the most up-to-date information. Please do not hesitate to consult with them.

SAFETY FIRST

This symbol, the industry's "Safety Alert Symbol", is used throughout this manual and on labels on the machine itself to warn of the possibility of personal injury. Read these instructions carefully. It is essential that you read the instructions and safety regulations before you attempt to assemble or use this unit.



DANGER : Indicates an imminently hazardous situation which, if not avoided, will result in death or serious injury.



WARNING : Indicates a potentially hazardous situation which, if not avoided, could result in death or serious injury.



CAUTION : Indicates a potentially hazardous situation which, if not avoided, could result in minor or moderate injury.

IMPORTANT : Indicates that equipment or property damage could result if instructions are not followed.

NOTE : Gives helpful information.

CONTENTS

▲ SAFE OPERATION	▲ -1
SERVICING OF VEHICLE	1
SPECIFICATIONS	3
SPECIFICATION TABLE	3
TRAVELING SPEEDS	4
VEHICLE LIMITATIONS	5
INSTRUMENT PANEL AND CONTROLS	6
LOCATION OF PARTS	6
PRE-OPERATION CHECK	10
DAILY CHECK	10
OPERATING THE ENGINE	11
STARTING THE ENGINE	11
Cold Weather Starting	13
Engine Hand Throttle	13
Block Heater	13
STOPPING THE ENGINE	14
WARMING UP	14
Warm-Up Transmission Oil in the Low Temperature Range	14
JUMP STARTING	14
OPERATING THE VEHICLE	16
OPERATING NEW VEHICLE	16
Do not Operate the Vehicle at Full Speed for the First 50 Hours	16
Changing Lubricating Oil for New Vehicles	16
STARTING	16
Locking and Unlocking the Door	16
Seat Belt	17
Tilt Steering Wheel	17
Seat Slide Lever	17
Head Light Switch	18
Hazard Light Switch	18
Turn Signal Light Switch	18
Horn Button	19
Work Light (Front)	19
Work Light (Rear)	19
Brake Pedal	20
Range Gear Shift Lever	20
4WD Lever	21
Parking Brake Lever	21
Speed Control Pedal	22
STOPPING	22
Stopping	22
CHECK DURING DRIVING	22
Immediately Stop the Engine if:	22

Easy Checker(TM).....	22
Fuel Gauge.....	23
Coolant Temperature Gauge.....	23
Hourmeter and Odometer.....	24
Speedometer.....	24
PARKING.....	25
Parking Brake Lever.....	25
ACCESSORY.....	25
12V Electric Outlet.....	25
Utility Box.....	25
Glove Box (Std.) and Glove Box Cover (if equipped).....	26
OPERATING TECHNIQUES.....	26
Differential Lock.....	26
Directions for Use of Power Steering.....	27
Unfamiliar Terrain.....	27
Driving in Reverse.....	27
Driving in "4WD".....	28
Turning the Vehicle.....	28
Hills.....	29
Traversing Hillsides.....	29
Sliding and Skidding.....	29
Driving through Water.....	30
OPERATING HAND THROTTLE.....	30
STATIONARY HYDRAULIC OUTLET.....	30
CARGO BED.....	31
CARGO BED.....	31
General Caution.....	31
Max. Cargo Load.....	31
Cargo Bed Tailgate.....	33
Raising and Lowering the Cargo Bed.....	33
Raising and Lowering the Cargo Bed [without hydraulic dump].....	35
HYDRAULIC OUTLET.....	36
HYDRAULIC OUTLET.....	36
Hydraulic Outlet Lever.....	36
Hydraulic Outlet Valve Coupler Connecting and Disconnecting.....	37
TIRES AND WHEELS.....	38
TIRES.....	38
Inflation Pressure.....	38
Tire Type and Use.....	38
WHEELS.....	39
SHOCK ABSORBERS.....	39
Shock Absorber Spring Adjustment.....	39
TOWING AND TRANSPORTING.....	40
TOWING AND TRANSPORTING.....	40
Rear Trailer Hitch.....	40
Front Trailer Hitch.....	40
Winch Mount Bracket.....	41
Transport the Vehicle Safely.....	41

MAINTENANCE.....	42
SERVICE INTERVALS	42
LUBRICANTS, FUEL AND COOLANT	45
PERIODIC SERVICE.....	49
HOW TO OPEN THE HOOD AND TILT THE SEAT.....	49
Hood	49
Seat	49
HOW TO RAISE THE CARGO BED.....	50
Raising and Lowering the Cargo Bed [if equipped with hydraulic dump].....	50
Raising and Lowering the Cargo Bed [without hydraulic dump]	50
JACK-UP POINT	50
Front End.....	50
Rear End.....	51
DAILY CHECK	51
Walk Around Inspection.....	51
Checking around Engine	51
Checking and Refueling.....	52
Checking Engine Oil Level.....	52
Checking Transmission Fluid Level.....	53
Checking Hydraulic Oil Tank Level.....	53
Checking Coolant Level.....	54
Cleaning Radiator Screen.....	54
Cleaning Oil Cooler Net.....	55
Checking Brake Fluid Level.....	55
Checking Brake Pedal	56
Checking Parking Brake	56
Checking Easy Checker(TM).....	56
Checking Head Light, Turn Signal Light (if equipped) etc.	56
Checking Seat Belt and ROPS	56
Checking Joint Boot.....	57
Checking Tire Inflation Pressure.....	58
Checking Backup Beeper	58
EVERY 50 HOURS	59
Greasing	59
Checking Engine Start System	60
EVERY 100 HOURS	61
Checking VHT Neutral Spring.....	61
Checking VHT Pressure Release	61
Checking Wheel Fastener Torque	62
Cleaning Air Cleaner Primary Element.....	62
Adjusting Alternator Belt Tension	63
Checking Fuel Line and Fuel Filter	63
Checking Battery Condition	64
Adjusting Toe-in.....	66
Cleaning Muffler.....	67
EVERY 200 HOURS	68
Adjusting Parking Brake	68
Replacing Engine Oil Filter	69
Changing Engine Oil.....	69
Replacing Transmission Oil Filter [VHT].....	70
Replacing Transmission Oil Filter [SUCTION].....	71

Changing Hydraulic Tank Oil.....	71
Checking Brake Pedal.....	72
Checking Brake Hose and Pipe.....	73
Checking Front Brake Case.....	73
Checking Brake Light Switch.....	74
Checking Radiator Hose, Pipe and Clamp.....	74
Checking Intake Air Line.....	75
Checking Hydraulic Oil Line.....	76
EVERY 300 HOURS.....	77
Checking Tire.....	77
EVERY 400 HOURS.....	78
Changing Front Knuckle Case Oil.....	78
Changing Transmission Fluid.....	78
Changing Front Axle Case Oil.....	79
EVERY 500 HOURS.....	80
Replacing Fuel Filter.....	80
EVERY 800 HOURS.....	80
Adjusting Engine Valve Clearance.....	80
EVERY 1500 HOURS.....	80
Checking Fuel Injection Nozzle Injection Pressure.....	80
EVERY 3000 HOURS.....	80
Checking Injection Pump.....	80
EVERY 1 YEAR.....	80
Replacing Air Cleaner Primary Element and Secondary Element.....	80
EVERY 2 YEARS.....	80
Changing Brake Fluid.....	80
Flushing Cooling System and Changing Coolant.....	80
Anti-Freeze.....	81
Replacing Radiator Hose (Water pipes).....	82
Replacing Hydraulic Oil Line.....	82
Replacing Fuel Hose.....	82
Replacing Engine Breather Hose.....	82
Replacing Brake Master Cylinder (Inner Parts).....	82
Replacing Front Brake Seal.....	82
Replacing Rear Brake Cylinder Seal.....	82
Replacing Intake Air Line.....	82
Replacing Air Conditioner Pipe and Hose.....	82
EVERY 4 YEARS.....	83
Replacing Brake Hose.....	83
SERVICE AS REQUIRED.....	83
Bleeding Fuel System.....	83
Cleaning around Engine.....	83
Replacing Fuse.....	83
Replacing Slow-Blow Fuses.....	85
Replacing Light Bulb.....	85
Checking Hydraulic Tank Suction Strainer.....	85
STORAGE.....	86
VEHICLE STORAGE.....	86
REMOVING THE VEHICLE FROM STORAGE.....	86
TROUBLESHOOTING.....	87

ENGINE TROUBLESHOOTING	87
BATTERY TROUBLESHOOTING	88
MACHINE TROUBLESHOOTING	89
OPTIONS.....	90
INDEX.....	91



SAFE OPERATION

Careful operation is your best insurance against an accident.

Read and understand this Operator's Manual carefully before operating the vehicle.

All operators, no matter how much experience they may have, should read this and other related manuals before operating the vehicle or any implement attached to it. It is the owner's obligation to instruct all operators in safe operation.

1. BEFORE OPERATING THE VEHICLE

1. Know your equipment and its limitations. Read this entire manual before attempting to start and operate the vehicle.
2. Pay special attention to the Danger, Warning and Caution labels on the vehicle.
3. Do not remove Roll-Over Protective Structures (ROPS) for any application and fasten seat belts at all times. This combination will reduce the risk of serious injury or death, should the vehicle be upset.
If the ROPS is loosened or removed for any reason, make sure that all parts are reinstalled correctly before operating the vehicle.
Never modify or repair a ROPS because welding, bending, drilling, grinding, or cutting may weaken the structure.
If any structural member of the ROPS is damaged, replace the entire structure at your local KUBOTA Dealer.

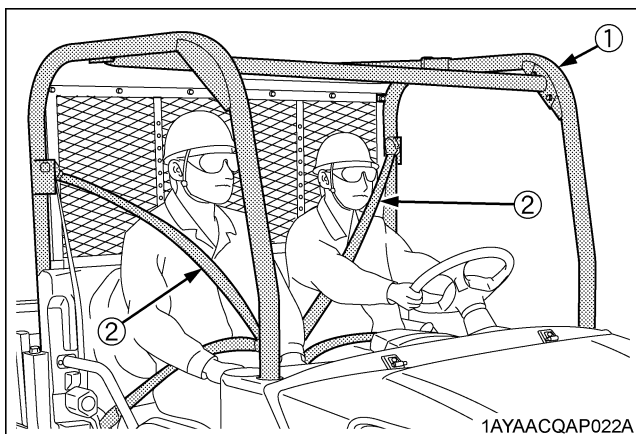

- (1) ROPS
(2) Seat belt

4. Always use the seat belts. Check the seat belts regularly and replace if frayed or damaged.
5. Do not operate the vehicle or any implement attached to it while under the influence of alcohol, medication, controlled substances or while fatigued.
6. Carefully check the vicinity before operating the vehicle or any implement attached to it. Check for overhead clearance which may interfere with the CAB or ROPS. Do not allow any bystanders around or near the vehicle during operation.
7. Never allow anyone under age 16 or without a valid driver's license to operate this vehicle.
8. Before allowing other people to use your vehicle, explain how to operate and have them read this manual before operation.
9. Never wear loose, torn, or bulky clothing around the vehicle. It may catch on moving parts or controls, leading to the risk of an accident. Use additional safety items, e.g. helmet, safety boots or shoes, eye and hearing protection, gloves, etc., as appropriate or required.
10. This vehicle is for off road use only.
KUBOTA does not recommend operating on public roads.
11. In addition to the driver, only 1 passenger should ride in the vehicle.
Minimum age for passenger is 5 years old.
12. Keep all shields in place and stay away from all moving parts.
13. Check brakes, speed control pedal, and other mechanical parts for improper adjustment and wear. Replace worn or damaged parts promptly. Check the tightness of all nuts and bolts regularly. (For further details, see "MAINTENANCE" section.)
14. Keep your vehicle clean. Dirt, grease, and trash build up may contribute to fires and lead to personal injury.
15. Use only implements meeting the specifications listed under "VEHICLE LIMITATIONS" in this manual or implements approved by KUBOTA.
16. The maximum cargo capacity of this vehicle is 500 kg (1100 lbs.). Reduce cargo capacity to match operating conditions.
Avoid top-heavy loading and ensure that the center-of-gravity remains as low as possible.
Do not carry anything which sticks outside the cargo bed.
17. Do not modify the vehicle. Unauthorized modification may affect the function of the vehicle, which may result in personal injury.
18. Do not carry small children on lap.

2. OPERATING THE VEHICLE

Operator safety is a priority. Safe operation, specifically with respect to overturning hazards, entails understanding the equipment and environmental conditions at the time of use. Some prohibited uses which can affect overturning hazards include traveling and turning with implements and loads carried too high etc. This manual sets forth some of the obvious risks, but the list is not, and cannot be, exhaustive. It is the operator's responsibility to be alert for any equipment or environmental condition that could compromise safe operation.

◆ Starting

1. Always sit in the operator's seat when starting engine or operating levers or controls.
2. Before starting the engine, make sure that all levers are in their neutral positions, that the parking brake is engaged, and that the hydraulic outlet (if equipped) is OFF. And make sure the engine hand throttle (if equipped) is in its idle engine speed position.
3. Do not start engine by shorting across starter terminals or bypassing the safety start switch. The vehicle may start in gear and move if normal starting circuitry is bypassed.
4. Be sure that the operator (and passenger) are properly positioned and seat belts are appropriately fastened.
5. Do not operate or idle engine in a non-ventilated area. Carbon monoxide gas is colorless, odorless, and deadly.

◆ Operating

1. Always wear the seat belt when operating the unit.
2. Do not wear headphones while operating.
3. Pull only from the trailer hitch (if equipped). Never hitch to any other point except trailer hitch; such arrangements will increase the risk of serious personal injury or death due to a vehicle upset.

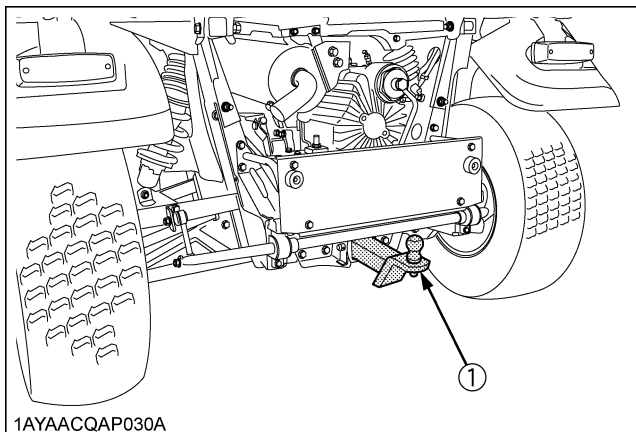

(1) Trailer hitch (if equipped)

4. Keep all shields and guards in place. Replace any that are missing or damaged.

5. Avoid sudden starts. To avoid rollovers, slow down when turning, on uneven ground, and before stopping. While increasing engine speed with the engine hand throttle (if equipped), operate the speed control pedal with great care to avoid sudden starts.
6. The vehicle cannot turn with the differential locked and attempting to do so could be dangerous.
7. Do not operate near ditches, holes, embankments, or other ground surface features which may collapse under the vehicle's weight. The risk of vehicle upset is even higher when the ground is loose or wet.
8. Watch where you are going at all times. Watch for and avoid obstacles. Be alert at row ends, near trees, and other obstructions.
9. When working in groups, always let the others know what you are going to do before you do it.
10. Never try to get on or off a moving vehicle.
11. Do not stand between vehicle and trailer unless parking brake is applied.

◆ Safety for children

Tragedy can occur if the operator is not alert to the presence of children. Children generally are attracted to vehicles and the work they do.

1. Never assume that children will remain where you last saw them.
2. Keep children out of the work area and under the watchful eye of another responsible adult.
3. Be alert and shut your vehicle down if children enter the work area.
4. Never carry children in the cargo bed. There is no safe place for them to ride. No person under the age of 5 may ride as a passenger in this vehicle. A passenger under 5 years of age requires special restraints which are not available with this vehicle.
5. Never allow children to operate the vehicle even under adult supervision.
6. Never allow children to play on the vehicle or on the implement.
7. Use extra caution when backing up. Look behind and down to make sure area is clear before moving.
8. Whenever possible, park your vehicle on a firm, flat and level surface. If this is not possible, park it across the slope. Set the parking brake(s), lower the implements to the ground, remove the key from the ignition and lock the door (if equipped) and chock the wheels.

◆ Operating on slopes

Slopes are a major factor related to loss-of-control and tip-over accidents, which can result in severe injury or death. All slopes require extra caution.

1. Travel straight up or down hill.
2. Reduce load when operating on hilly or over rough terrain.
3. Keep front wheels straight at crest of hill or going over bumps.

4. Do not stop or start suddenly when going uphill or downhill. Be especially cautious when changing direction on slopes.
5. If vehicle stops or loses power going up a hill, lock parking brake to hold vehicle on slope. Maintain direction of travel and release brake slowly. Back straight downhill while maintaining control. Do not turn vehicle sideways. Vehicle is more stable in a straight forward or rearward position.
6. When riding on soft terrain, turn front wheels slightly uphill to keep vehicle on a straight line across the hill.
7. If the vehicle begins to tip, turn front wheels downhill to gain control before proceeding.
 - (1) To avoid upsets, always back up steep slopes. If you cannot back up the slope or if you feel uneasy on it, do not operate on it. Stay off slopes too steep for safe operation.
 - (2) Driving forward out of a ditch, mired condition or up a steep slope increases the risk of a vehicle to be upset backward. Always back out of these situations. Extra caution is required with 4-wheel drive mode because the increased traction can give the operator false confidence in the vehicle's ability to climb slopes.
 - (3) Keep all movement on slopes slow and gradual. Do not make sudden changes in speed, direction or apply brake and make sudden motions of the steering wheel.
 - (4) Special attention should be made to the weight and location of implements and loads as such will affect the stability of the vehicle.

◆ Operation in inclement conditions

1. Only operate during daylight or with good artificial light.
2. Operate vehicle in an open, unobstructed area.
3. Use helmet and/or protective gear as appropriate or required for the operating conditions.
4. Reduce speed according to trail, terrain and visibility conditions.
5. Never drive exceeding the limit of visibility. Slow down near crest of hill until getting a clear view of the other side.
6. Stay alert for holes, rocks and other hidden hazards in the terrain.
7. Never cross any body of water where depth may be unknown to the operator (Deep water is considered anything in excess the bottom edge of the axle cap). Choose a course within the waterway where both banks have a gradual incline. Cross at a point known to be safe.

◆ Driving the vehicle at high speeds

1. Check the front wheel engagement. The braking characteristics are different between 2 and 4 wheel drive. Be aware of the difference and use carefully.
2. Always slow the vehicle down before turning. Turning at high speed may tip the vehicle over.
3. Turn the headlights on.

4. Drive at speeds that allow you to maintain control at all times.
5. Do not apply the differential lock while traveling at high speeds. The vehicle may run out of control.
6. Avoid sudden motions of the steering wheel as they can lead to a dangerous loss of stability. The risk is especially great when the vehicle is traveling at high speeds.

◆ Other miscellaneous

1. Clean platform if dirty and remove any debris from around foot controls.
2. Always keep both hands on the steering wheel.
3. Always keep arms and legs inside the operating compartment.
4. Never operate the vehicle while standing.
5. Do not tow a cart with any riders on it.
6. Never attempt wheelies, jumps or other stunts.

3. HAULING LOADS IN THE CARGO BED

1. No riders in cargo bed or anywhere else.
2. Do not overload vehicle. Securely anchor all loads.
3. Be sure load is evenly distributed.
4. Reduce cargo capacity when operating on rough or hilly terrain.
5. Balance loads evenly and secure them. Braking could shift the load and affect vehicle stability.
6. Never operate vehicle with the cargo bed raised.
7. Operate cargo bed dump with vehicle stationary and parking brake locked. Do not dump while moving.
8. Operate hydraulic dump (if equipped) on level ground only.
9. Operate dump from operator's seat only.
10. Do not place hands or body under the cargo bed when lowering bed.

4. OPERATING HYDRAULIC OUTLET DRIVEN EQUIPMENT (IF EQUIPPED)

1. Before installing or using hydraulic outlet driven equipment, read the manufacturer's manual and review the safety labels attached to the equipment.
2. Wait until all moving components have completely stopped before getting off the vehicle, connecting, disconnecting, adjusting, cleaning, or servicing any hydraulically driven equipment.
3. When operating stationary hydraulically driven equipment, always apply the vehicle parking brake and place chocks behind and in front of the rear wheels. Stay clear of all rotating parts. Never step over rotating parts.

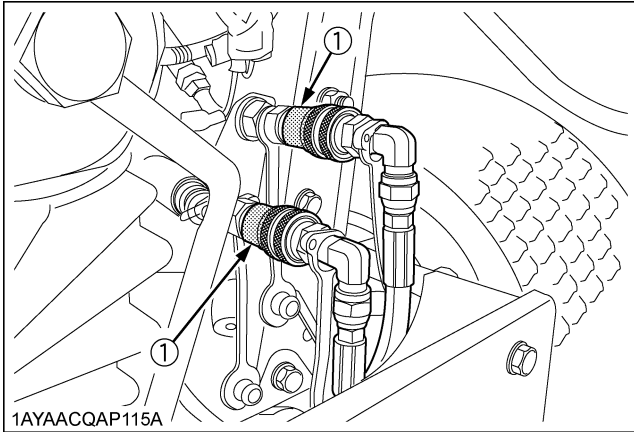

(1) Hydraulic outlet (if equipped)

5. PARKING THE VEHICLE

1. Make sure the HYDRAULIC OUTLET is off (if equipped), lower all implements to the ground, place all control levers in their neutral positions, set the parking brake, stop the engine, and remove the key.
2. Make sure that the vehicle has come to a complete stop before dismounting.
3. Avoid parking on steep slopes, if at all possible park on a firm and level surface; if not, park across a slope with chock the wheels and always with attachment on the ground.
Failure to comply with this warning may allow the vehicle to move and could cause injury or death.

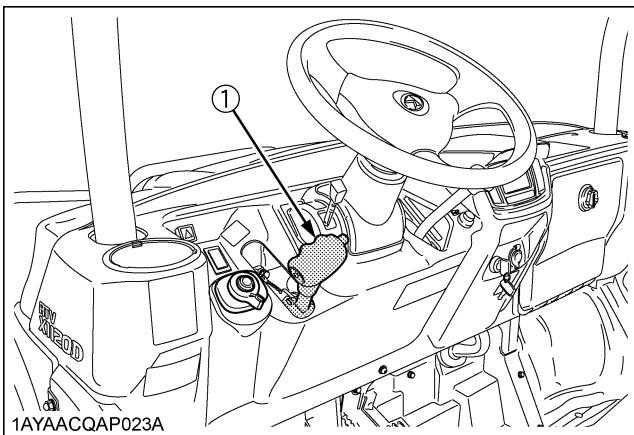

(1) Parking brake lever

6. TRANSPORTING

1. Disengage power to attachment(s) when transporting or not in use.
2. Do not tow this vehicle. Use a suitable truck or trailer when transporting on public roads.
3. Use extra care when loading or unloading the vehicle into a trailer or truck.

7. SERVICING THE VEHICLE

Before servicing the vehicle, park it on a firm, flat and level surface, set the parking brake, lower all implements to the ground, place the range gear shift lever in neutral, stop the engine and remove the key.

1. Allow the vehicle time to cool off before working on or near the engine, muffler, radiator, etc.
2. Always stop the engine before refueling. Avoid spills and overfilling.
3. Do not smoke when working around battery or when refueling. Keep all sparks and flames away from battery and fuel tank. The battery presents an explosive hazard, because it gives off hydrogen and oxygen especially when recharging.
4. Before "jump starting" a dead battery, read and follow all of the instructions. (See "JUMP STARTING" in "OPERATING THE ENGINE" section.)
5. Keep first aid kit and fire extinguisher handy at all times.
6. Disconnect the battery's ground cable before working on or near electric components.
7. To avoid the possibility of battery explosion, do not use or charge the refillable type battery if the fluid level is below the LOWER (lower limit level) mark. Check the fluid level regularly and add distilled water as required so that the fluid level is between the UPPER and LOWER marks.
8. To avoid sparks from an accidental short circuit, always disconnect the battery's ground cable (-) first and reconnect it last.

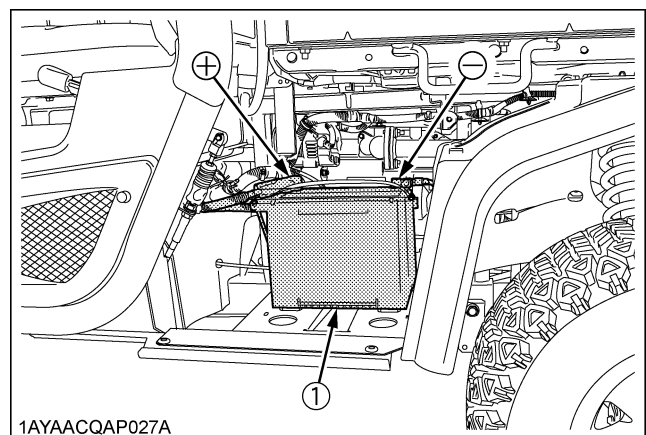

(1) Battery

9. Do not remove radiator cap while coolant is hot. When cool, slowly rotate cap to the first stop and allow sufficient time for excess pressure to escape before removing the cap completely. This vehicle has a coolant recovery tank, add coolant or water to the tank, not the radiator. (See "Checking Coolant Level" in "DAILY CHECK" in "PERIODIC SERVICE" section.)

10. Do not attempt to mount a tire on a rim. This should be done by a qualified person with the proper equipment.
11. Always maintain the correct tire pressure. Do not inflate tires above the recommended pressure shown in the operator's manual.

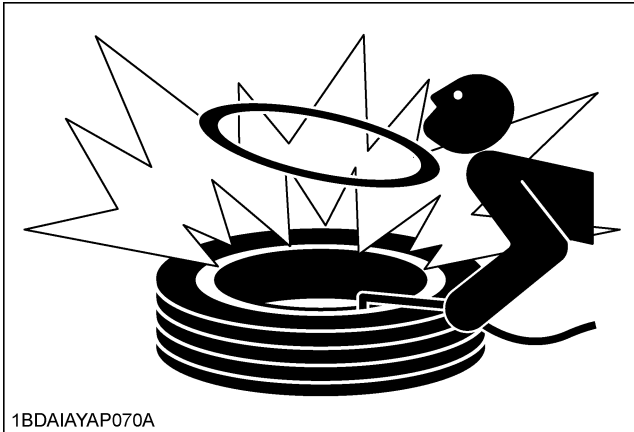

12. Securely support the vehicle when changing wheels.
13. Make sure that wheel bolts and nuts have been tightened to the specified torque.
14. Do not work under any hydraulically supported devices. They can settle, suddenly leak down, or be accidentally lowered. If it is necessary to work under the vehicle or any vehicle elements for servicing or adjustment, securely support them with stands or suitable blocking beforehand.
15. Escaping hydraulic fluid under pressure has sufficient force to penetrate skin causing serious personal injury. Before disconnecting hydraulic lines, be sure to release all residual pressure. Before applying pressure to the hydraulic system, make sure that all connections are tight and that all lines, pipes, and hoses are free of damage.
"High pressure fluid - Injection into body" hazard warning.

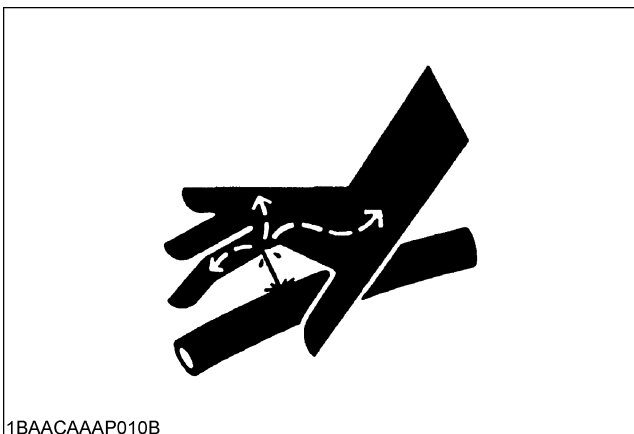

16. Fluid escaping from pinholes may be invisible. Do not use hands to search for suspected leaks; use a piece of cardboard or wood. Use of safety goggles or other eye protection is also highly recommended. If injured by escaping fluid, see a medical doctor at once. This fluid will produce gangrene or severe allergic reaction.

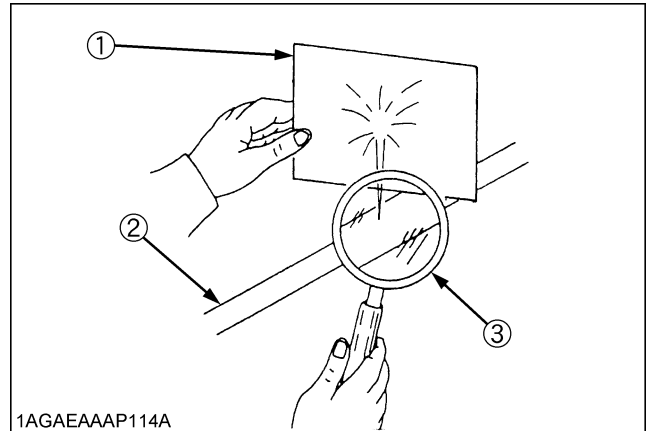

- (1) Cardboard
(2) Hydraulic line
(3) Magnifying glass

17. Waste products such as used oil, fuel, hydraulic fluid, and batteries, can harm the environment, people, pets and wildlife. Please dispose properly.
See your local Recycling Center or KUBOTA Dealer to learn how to recycle or get rid of waste products.

8. DANGER, WARNING AND CAUTION LABELS

(1) Part No. K7591-6522-1

▲ DANGER

TO AVOID POSSIBLE INJURY OR DEATH FROM A MACHINE RUNAWAY:

1. Do not start engine by shorting across starter terminals or bypassing the safety start switch. The vehicle may start in gear and move if normal starting circuitry is bypassed.
2. Start engine only from operator's seat with range shift lever in neutral position and hydraulic outlet off (if equipped).

1AYAACQAP016A

(2) Part No. K7591-6541-1

▲ WARNING

TO AVOID PERSONAL INJURY OR DEATH:

1. Do not remove Roll-Over Protective Structures (ROPS) for any application.
2. Do not modify or repair a ROPS because welding, grinding, drilling or cutting any portion may weaken the structure.

1AYAACQAP006A

[3 point type seat belt]
(3) Part No. K7421-6526-1

▲ WARNING

TO AVOID PERSONAL INJURY OR DEATH: Always fasten your seat belt.

▲ WARNING

TO AVOID PERSONAL INJURY DUE TO LOSS OF STEERING CONTROL: Do not depress the differential lock pedal at high speed.

1AYAACQAP184A

[2 point type seat belt]
(3) Part No. K7591-6526-1

▲ WARNING

TO AVOID PERSONAL INJURY OR DEATH: Always fasten your seat belt.

▲ WARNING

TO AVOID PERSONAL INJURY DUE TO LOSS OF STEERING CONTROL: Do not depress the differential lock pedal at high speed.

1AYAACQAP014A

(4) Part No. K7591-6528-2

▲ WARNING

TO AVOID PERSONAL INJURY: Do not operate the vehicle with the front hood open. Impaired visibility of the operator may cause loss of vehicle control. Latch the hood securely before operating the vehicle.

1AYAACQAP019A

(6) Part No. K7591-6538-2

▲ CAUTION

NO STEP

1AYAACQAP004A

(5) Part No. K7591-6523-2

▲ WARNING

TO AVOID PERSONAL INJURY:

1. Do not carry passengers in cargo bed.
2. Do not travel with the cargo bed in raised position.

IMPORTANT

1. Max. cargo load should not exceed "CBC" or "CL".
CBC (Cargo Bed Capacity): 500Kg (1100 lb)
CL (Cargo Load): May vary on models. Refer to operator's manual for details.
CL = (payload capacity) - (operator+passenger+opt.+acc.+cabin) weight

2. TO AVOID TAIL GATE DAMAGE:
Remove the rear tow hitch when tail gate Stopper Wire is removed and cargo bed is raised.

1AYAACQAP015A

(7) Part No. K7591-6549-1

▲ WARNING

TO AVOID PERSONAL INJURY: Do not open breather for coolant while coolant is hot.

1AYAACQAP008A

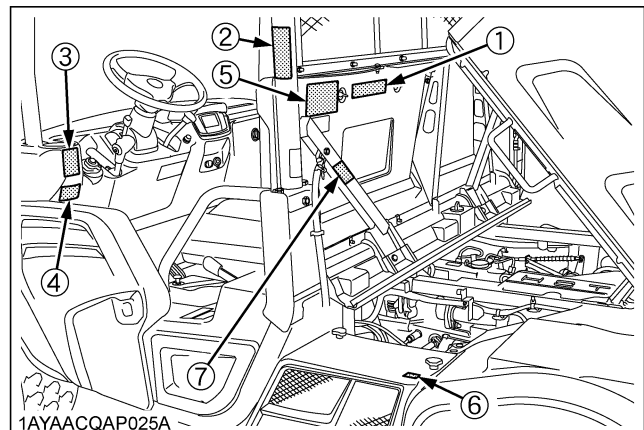

1AYAACQAP025A

1AYAACQAP128A

(1) Part No. K7591-6524-1



1AYAACQAP002A

(2) Part No. K7591-6544-2

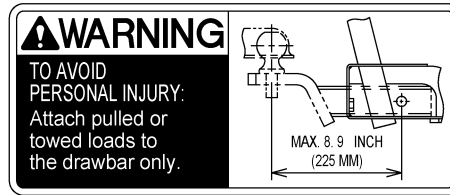

1AYAACQAP007A

(3) Part No. K7591-6521-2

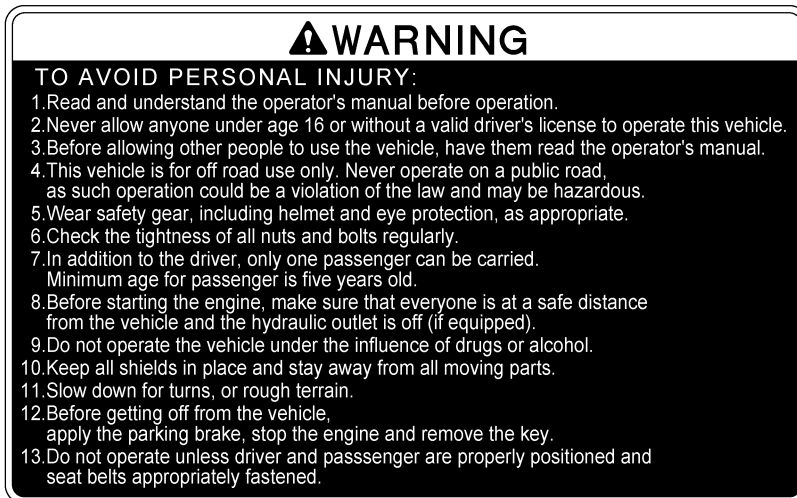

1AYAACQAP020A

[3 point type seat belt]

(4) Part No. K7421-6527-1



1AYAACQAP185A

[2 point type seat belt]

(4) Part No. K7591-6527-1



1AYAACQAP013A

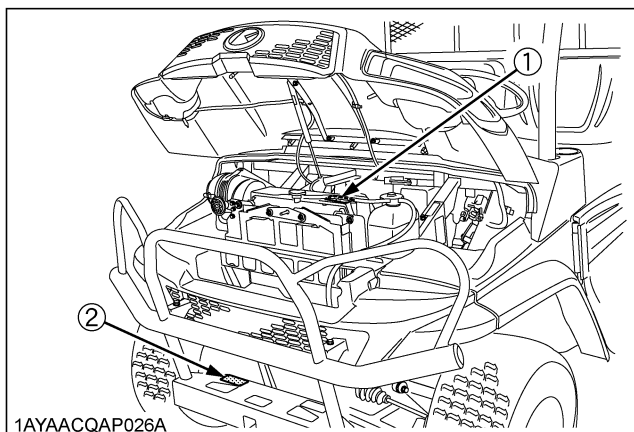

1AYAACQAP026A

1AYAACQAP129A

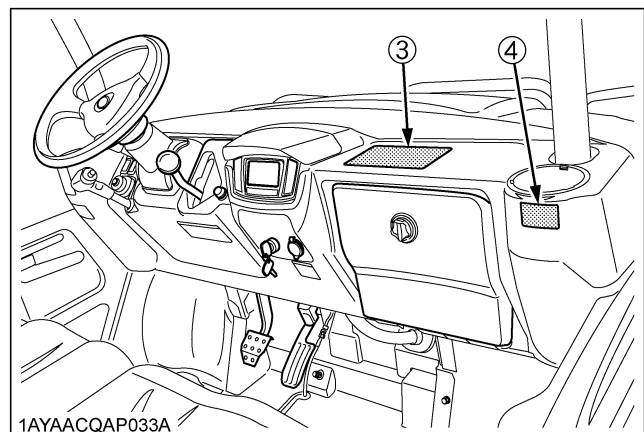

1AYAACQAP033A

(1) Part No. K7591-6542-1



WARNING

TO AVOID PERSONAL INJURY:
Use the Safety Support or Propping Rod when working near a raised cargo bed or attachment.

1AYAACQAP005A

(2) Part No. K7421-6577-2



WARNING

TO AVOID PERSONAL INJURY OR DEATH:
Secure the door properly.

1AYAACQAP021A

(3) Part No. K7591-6545-2

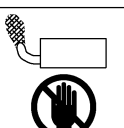
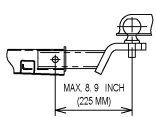
 	<p>WARNING</p> <p>TO AVOID PERSONAL INJURY:</p> <ol style="list-style-type: none"> 1. Before touching any part of an exhaust system, be absolutely sure that it has had sufficient time to cool. 2. Always wear safety goggles and a (face) mask. 3. The particulate matter contained in the muffler contains chemicals that are harmful to people, animal and marine life. 4. If you are unable to do this work, have it done by your KUBOTA Dealer. 	<p>Maintenance</p> <p>The swirl type spark arrester should be cleaned after every 100 hours of use.</p> <ol style="list-style-type: none"> 1. Set vehicle in an open area away from combustible materials and on flat surface. 2. Apply parking brake and shift range gear shift lever into N(neutral) position. 3. Remove the drain plug located on the bottom of the muffler body. 4. Start engine and raise and lower engine revolution while tapping on the muffler with a rubber mallet until the carbon particles are purged from the muffler. 5. Stop the engine. 6. Reinstall the drain plug. 	<p>WARNING</p> <p>TO AVOID PERSONAL INJURY: Attach pulled or towed loads to the drawbar only.</p>  <p>MAX. 8.9 INCH (225 MM)</p>	<p>IMPORTANT</p> <ol style="list-style-type: none"> 1. Carefully read the loading information and trailer hitch sections in the Operator's Manual. 2. Towing Capacity <ul style="list-style-type: none"> • Max. Towing Load -590kg (1300lbs) • Max. Tongue Weight -50kg (110lbs)
---	---	--	---	--

1AYAACQAP009A

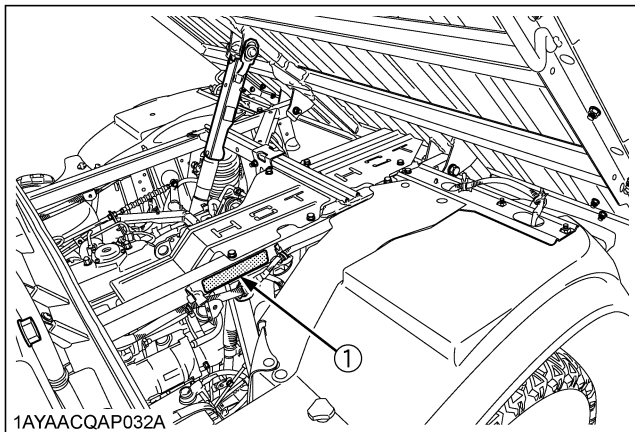

1AYAACQAP032A

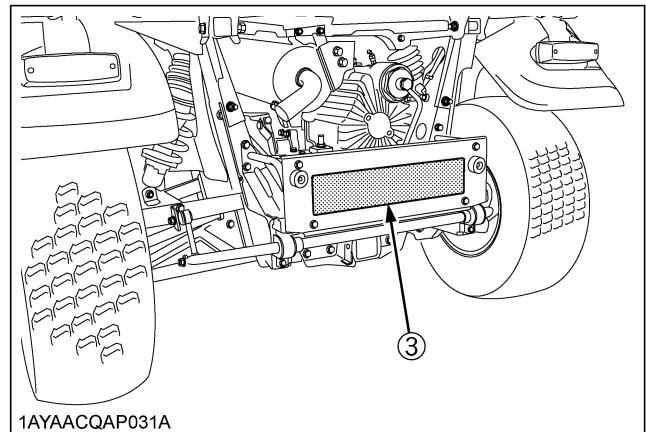

1AYAACQAP031A

[RTV-X1120D only]

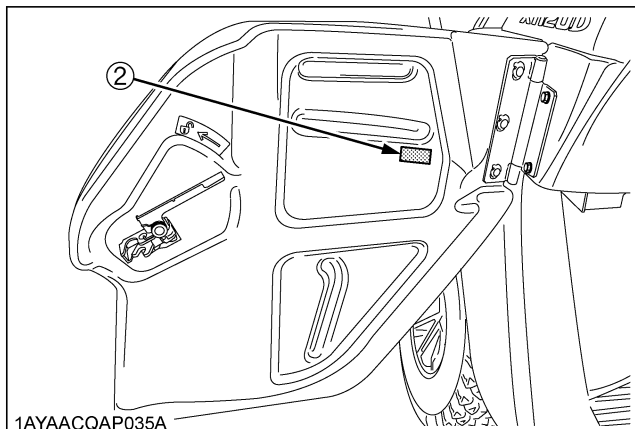

1AYAACQAP035A

[RTV-X1120D only]

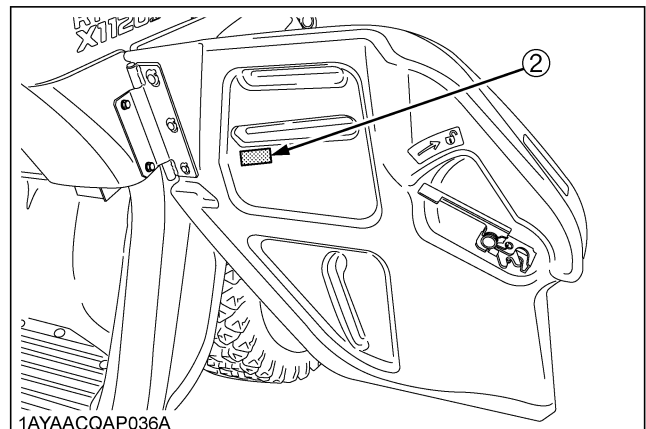

1AYAACQAP036A

1AYAACQAP131A

(1) Part No. K7591-6534-3



1AYAACQAP003A

(2) Part No. K7591-6547-1



1AYAACQAP010A

(3) Part No. K7591-6533-1



1AYAACQAP010A

(4) Part No. K7591-6548-1

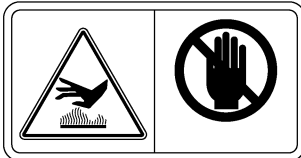

1AYAACQAP011A

(5) Part No. K7591-6532-1



1AYAACQAP017A

(6) Part No. K7591-6542-1



1AYAACQAP005A

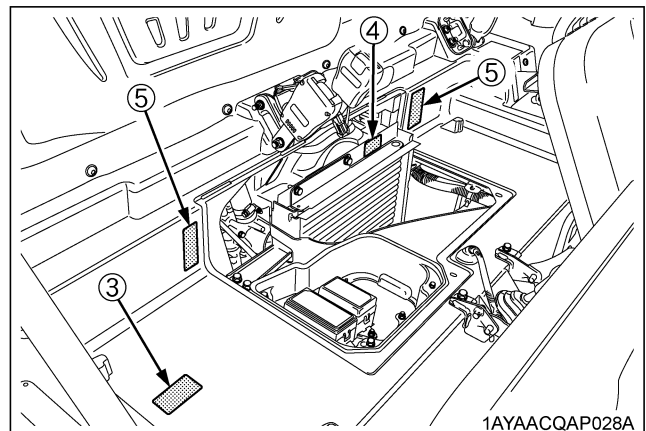
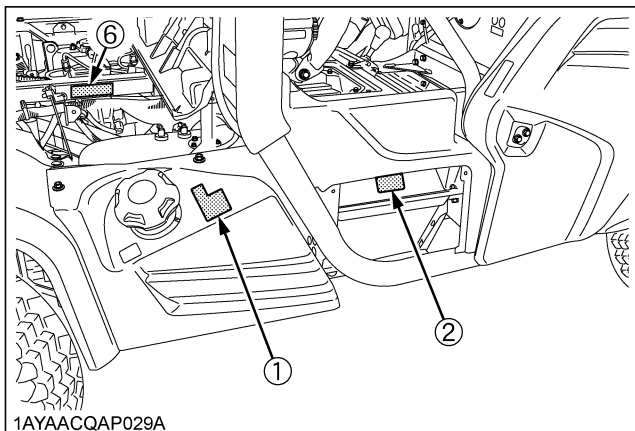

▲-10 SAFE OPERATION

[RTV-X900]

(1) Part No. K1221-6118-1

MAINTENANCE FREE • SANS ENTRETIEN • LIBRE DE MANTENIMIENTO

! DANGER/POISON ¡PELIGRO/VENENO!

SHIELD EYES. EXPLOSIVE GASES CAN CAUSE BLINDNESS OR INJURY.	NO • SPARKS • FLAMES • SMOKING	SULFURIC ACID CAN CAUSE BLINDNESS OR SEVERE BURNS. L'ACIDE SULFURIQUE PEUT CAUSER LA CECITE OU DES OU BRULURES GRAVES.	FLUSH EYES IMMEDIATELY WITH WATER. GET MEDICAL HELP FAST. RINCEZ LES YEUX A L'EAU IMMEDIATEMENT CONSULTEZ UN MEDECIN RAPIDEMENT.
PROTEGEZ LES YEUX. LES GAZ EXPLOSIFS PEUVENT BLESSEZ OU RENDRE AVEUGLE.	ÉVITER • LES ÉTINCELLES • LES FLAMMES • DE FUMER	ÁCIDO SULFURICO PUEDE CAUSAR CEGUERA O QUEMADURAS FUERTES.	ENJUAGUE LOS OJOS INMEDIATAMENTE CON AGUA. ACUDA RAPIDO CON EL MEDICO.
PROTEJA LOS OJOS. LOS GASES EXPLOSIVOS PUEDEN CAUSAR DANOS O CEGUERA.	NO • CHISPAS • FLAMAS • CIGARROS	KEEP OUT OF THE REACH OF CHILDREN. DO NOT TIP. DO NOT OPEN BATTERY! TENIR HORS DE LA PORTÉE DES ENFANTS. NE PAS RENVERSER. NE PAS OUVRIR LA BATTERIE! ALÉJESE DEL ALCANCE DE LOS NIÑOS. NO VOLTEAR. ¡NO ABRIR LA BATERIA!	

CALIFORNIA PROPOSITION 65 WARNING: Batteries, battery posts, terminals and related accessories contain lead and lead compounds, and other chemicals known to the State of California to cause cancer and birth defects or other reproductive harm. WASH HANDS AFTER HANDLING.

Dist. by/por/par: EPM Products, Baltimore, MD 21226

MADE IN U.S.A. FABRIQUE AUX E.U.A. HECHO EN E.U.A.

3-9312 **12V**

PART NO. CCA @ 8°F Ah @ 20HR

1BDFAIAP136A

[RTV-X1120D]

(1) Part No. K7731-6114-1

						SMF 24R-670								
FLAMMABLES	SHIELD EYES	KEEP OUT OF THE REACH OF CHILDREN	CAUTIONS OF SULFURIC ACID	READ INSTRUCTION MANUAL CAREFULLY	EXPLOSIVE									
DANGER EXPLOSIVE GASES CIGARETTES, FLAMES OR SPARKS COULD CAUSE BATTERY TO EXPLODE. ALWAYS SHIELD EYES AND FACE FROM BATTERY. DO NOT CHARGE OR USE BOOSTER CABLES OR ADJUST POST CONNECTIONS WITHOUT PROPER INSTRUCTION AND TRAINING. CALIFORNIA PROPOSITION 65 WARNING: Batteries, battery posts, terminals and related accessories contain lead and lead compounds, and other chemicals known to the State of California to cause cancer and birth defects or other reproductive harm. WASH HANDS AFTER HANDLING.		POISON CAUSES SEVERE BURNS CONTAINS SULFURIC ACID. AVOID CONTACT WITH SKIN, EYES OR CLOTHING. IN EVENT OF ACCIDENT FLUSH WITH WATER AND CALL A PHYSICIAN IMMEDIATELY. KEEP OUT OF REACH OF CHILDREN				<table border="1"> <tr> <td>NOMINAL VOLTAGE</td> <td>12V</td> </tr> <tr> <td>COLD CRANKING AMPS(SAE)</td> <td>670</td> </tr> <tr> <td>COLD CRANKING AMPS(EN)</td> <td>800</td> </tr> <tr> <td>AMP HOURS(@20 hr Rate)</td> <td>115</td> </tr> </table>	NOMINAL VOLTAGE	12V	COLD CRANKING AMPS(SAE)	670	COLD CRANKING AMPS(EN)	800	AMP HOURS(@20 hr Rate)	115
NOMINAL VOLTAGE	12V													
COLD CRANKING AMPS(SAE)	670													
COLD CRANKING AMPS(EN)	800													
AMP HOURS(@20 hr Rate)	115													
FITTING DATE 0 1 2 3 4 5 6 7 8 9 YEAR		INDICATOR ● OK ○ CHARGE ● REPLACE		MADE IN KOREA										
MONTH 1 2 3 4 5 6 7 8 9 10 11 12														

1AYAACQAP249A

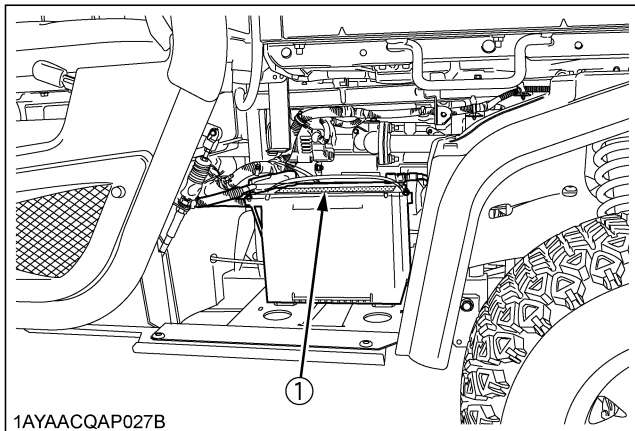

1AYAACQAP027B

1AYAACQAP252A

(1) Part No. K7591-6531-1



1AYAACQAP018A

(2) Part No. K7591-6583-3



1AYAACQAP183A

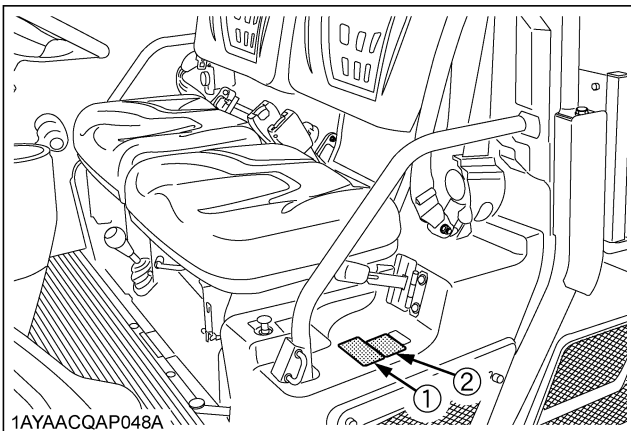

1AYAACQAP048A

1AYAACQAP134A

9. CARE OF DANGER, WARNING AND CAUTION LABELS

1. Keep danger, warning and caution labels clean and free from obstructing material.
2. Clean danger, warning and caution labels with soap and water, dry with a soft cloth.
3. Replace damaged or missing danger, warning and caution labels with new labels from your local KUBOTA Dealer.
4. If a component with danger, warning and caution label(s) affixed is replaced with new part, make sure new label(s) is(are) attached in the same location(s) as the replaced component.
5. Mount new danger, warning and caution labels by applying on a clean dry surface and pressing any bubbles to outside edge.

SERVICING OF VEHICLE

Your dealer is interested in your new vehicle and has the desire to help you get the most value from it. After reading this manual thoroughly, you will find that you can do some of the regular maintenance by yourself.

However, when in need of parts or major service, be sure to see your KUBOTA Dealer.

For service, contact the KUBOTA Dealership from which you purchased your vehicle or your local KUBOTA Dealer.

When in need of parts, be prepared to give your dealer the serial number of the vehicle, engine, transmission and ROPS.

Locate the serial numbers now and record them in the space provided.

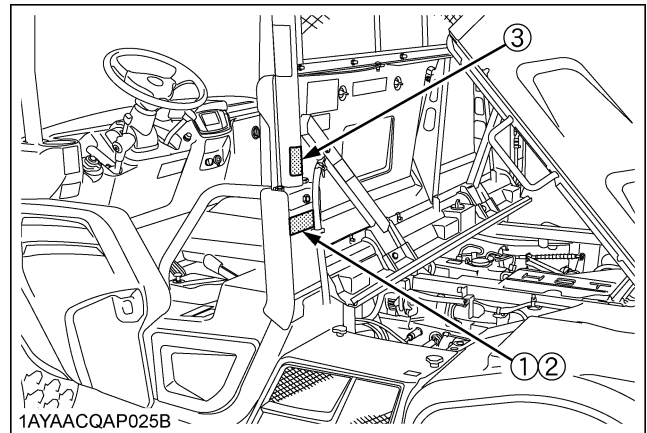

- (1) Vehicle identification plate
- (2) Product identification number
- (3) ROPS serial number

	Type	Serial No.
Vehicle		
Engine		
Transmission		
ROPS		
Product Identification Number		
Date of Purchase		
Name of Dealer (To be filled in by purchaser)		

◆ Warranty

This vehicle is warranted under the Kubota Limited Express warranty a copy of which may be obtained from your selling dealer. No warranty shall, however, apply if the vehicle has not been handled according to the instruction given in the Operator's Manual even it is within the warranty period.

◆ Scrapping the vehicle and its procedure

To put the vehicle out of service, correctly follow the local rules and regulations of the country or territory where you scrap it. If you have questions, consult your local KUBOTA Dealer.

[RTV-X900]

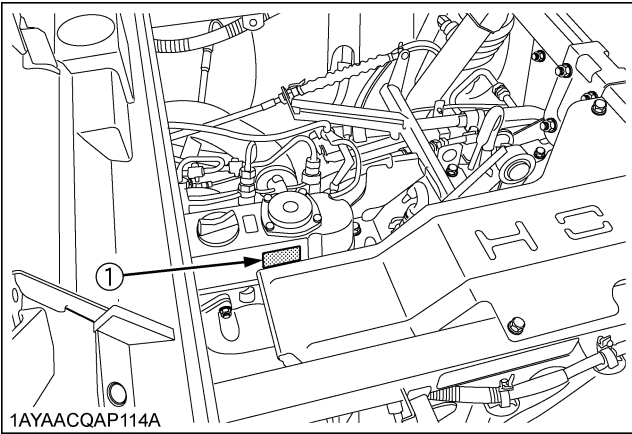

[RTV-X1120D]

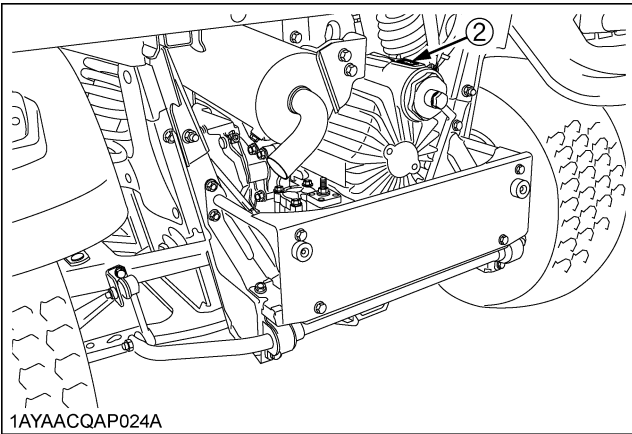
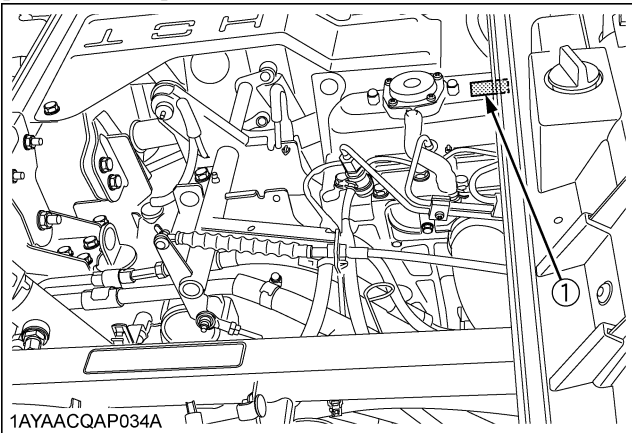

(1) Engine serial number

(2) Transmission assy serial number

SPECIFICATIONS

SPECIFICATION TABLE

Model			RTV-X900		RTV-X1120D		
			General Purpose	Worksite /Orange	Worksite /Camo	Worksite /Orange	Worksite /Camo
Engine	Make		D902		D1105		
	Type		3 cylinders, 4-cycle, diesel, OHV				
	Displacement	L (cu. in.)	0.898 (54.802)		1.123 (68.530)		
	Horsepower	kW (HP)	16.1 (21.6)		18.5 (24.8)		
	Rated revolution	rpm	3200		3000		
	Low idling revolution	rpm	1300 to 1400		1350 to 1450		
Fuel Capacity		L (U.S.gals)	30 (7.9)				
Transmission			Continuously variable hydro transmission (VHT)				
Wheels, Drive system			4, Rear 2WD or 4WD				
Differential lock			Standard; foot operated with mechanical holder				
Gear selection			Hi-Low range forward, neutral, reverse				
Brakes	Front / Rear		Wet disk brake				
	Parking brake		Rear wheel, hand lever				
Steering			Hydrostatic power				
Suspension	Front		Independent, Dual A-Arm type				
	Rear						
Dimensions	Length	mm (in.)	3055 (120.3)	3110 (122.5)			
	Width	mm (in.)	1605 (63.2)				
	Height, overall	mm (in.)	2020 (79.5)				
	Front tread centers	mm (in.)	1240 (48.8) HDWS, ATV				
	Rear tread centers	mm (in.)	1290 (50.8) Turf				
	Wheelbase	mm (in.)	2045 (80.5)				
	Ground clearance	front axle	mm (in.)	266 (10.5)			
		rear axle	mm (in.)	263 (10.4)			
Turning diameter		m (ft)	8.0 (26.2)				
Max. Rolling weight (Towing capacity)		kg (lbs.)	Rear: 590 (1300), Front: 295 (650)				
Payload capacity		kg (lbs.)	755 (1664)	725 (1598)	685 (1510)		
Weight		kg (lbs.)	865 (1907)	895 (1973)	935 (2061)		
Gross Vehicle Weight Rating (GVWR)		kg (lbs.)	1620 (3571)				

4 SPECIFICATIONS

Model			RTV-X900			RTV-X1120D	
			General Purpose	Worksite /Orange	Worksite /Camo	Worksite /Orange	Worksite /Camo
Cargo bed	Width	mm (in.)	1465 (57.7)				
	Length	mm (in.)	1030 (40.5)				
	Depth	mm (in.)	285 (11.2)				
	Volume	m ³ (cu.ft.)	0.43 (15.2)				
	Bed height (unloaded)	mm (in.)	887 (34.9)				
	Cargo bed capacity	kg (lbs.)	500 (1102)				
Sound level, operator ear		db (A)	85			84	
Tires	Front		25x10-12 ATV, 6PLY 25x10-12 HDWS, 6PLY 25x12-12 Turf, 4PLY		25x10-12 ATV, 6PLY 25x10-12 HDWS, 6PLY		
	Rear		25x10-12 ATV, 6PLY 25x10-12 HDWS, 6PLY 25x12-12 Turf, 4PLY		25x10-12 ATV, 6PLY 25x10-12 HDWS, 6PLY		
Tilt steering wheel			-	Std.			
Seat belt			2 point type			3 point type	
Front deluxe guard			-	Std.	Std.	-	-
Front deluxe guard with light guard			-	-	-	Std.	Std.
Body color			Orange	Orange	Camo	Orange	Camo
Bed lift			-	Std.	Std.	Std.	Std.
Speedometer			Std.	Std.	Std.	Std.	Std.
Door			-	-	-	Std.	Std.
Seat slide			-	Std.	Std.	Std.	Std.

NOTE :

- The company reserves the right to change the specifications without notice.
- The values in "Ground clearance" and "Weight" are those of the machine equipped with the tires in the table above.

TRAVELING SPEEDS

Range gear shift lever	Gear position		Traveling speeds	
			RTV-X900	RTV-X1120D
	Low	km/h (mph)	24 (15)	25 (16)
High	km/h (mph)	40 (25)	46 (29)	
Reverse	km/h (mph)	27 (17)	35 (22)	

VEHICLE LIMITATIONS

The KUBOTA Vehicle has been thoroughly tested for proper performance with implements sold or approved by KUBOTA. Use with implements which are not sold or approved by KUBOTA and which exceed the maximum specifications listed below, or which are otherwise unfit for use with the KUBOTA Vehicle may result in malfunctions or failures of the vehicle, damage to other property and injury to the operator or others. [Any malfunctions or failures of the vehicle resulting from use with improper implements are not covered by the warranty]

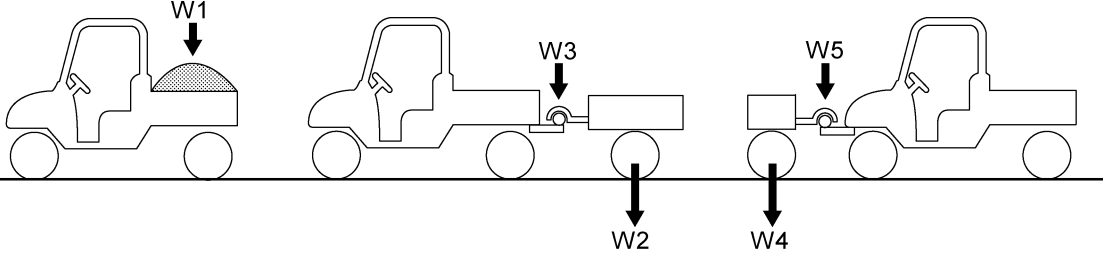
Cargo bed	<p>Max. Cargo loading weight (W1) should not exceed "CBC" and "PCL". PCL (Permissible Cargo load) is determined by the following calculus equation.</p> <p>$PCL = PC - (\text{operator} + \text{passenger} + \text{opt.} + \text{acc.} + \text{cabin}) \text{ weight}$</p> <p>CBC (Cargo bed capacity): 500 kg (1100 lbs.) PC: Payload Capacity opt.: option acc.: accessory cabin: 125 kg (275 lbs.)</p>
Rear trailer hitch	<p>Max. rolling weight (W2): 590 kg (1300 lbs.) Max. tongue weight (W3): 50 kg (110 lbs.)</p>
Front trailer hitch	<p>Max. rolling weight (W4): 295 kg (650 lbs.) Max. tongue weight (W5): 50 kg (110 lbs.)</p>
 <p style="font-size: small; margin-top: 10px;">1AYAAAAAP092A</p>	

[Payload Capacity (PC)]

Model	RTV-X900		RTV-X1120D
	General Purpose model	Worksite model	Worksite model
Payload capacity	755 kg (1664 lbs.)	725 kg (1598 lbs.)	685 kg (1510 lbs.)

Rolling weight: Trailer weight + Trailer load

- Above mentioned specifications are based on level ground condition.

INSTRUMENT PANEL AND CONTROLS

LOCATION OF PARTS

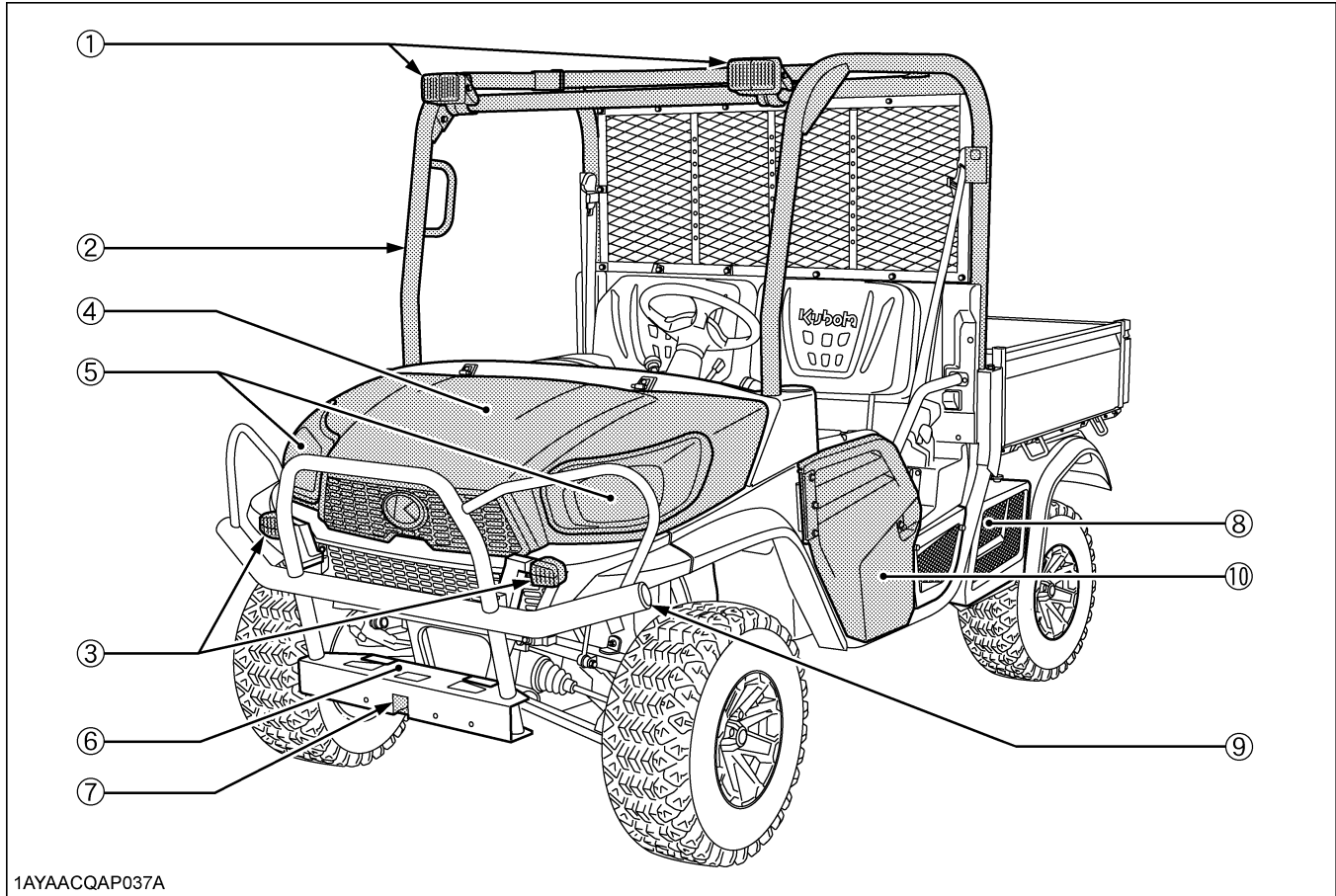

1AYAACQAP037A

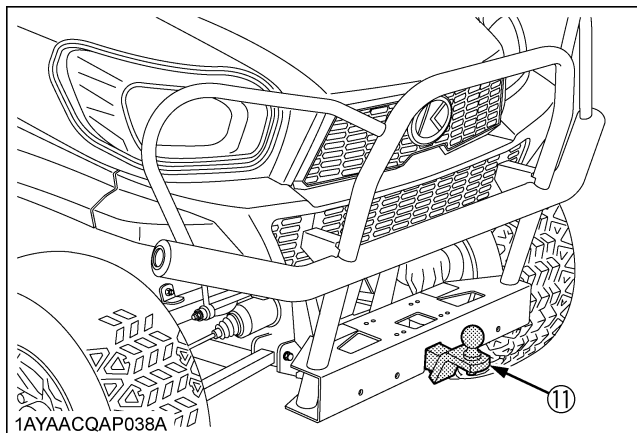

1AYAACQAP038A

ILLUSTRATED CONTENTS

(1) Front work light (if equipped).....	19
(2) ROPS.....	--
(3) Hazard / Turn signal light (if equipped).....	18, 18
(4) Front hood.....	49
(5) Headlights.....	18
(6) Winch mount bracket.....	41
(7) Front trailer hitch bracket.....	40
(8) Battery.....	64
(9) Front guard.....	--
(10) Door (RTV-X1120D only).....	16
(11) Front trailer hitch (if equipped).....	40

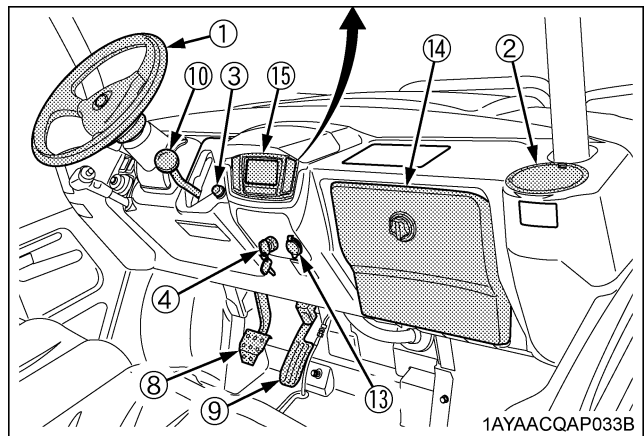
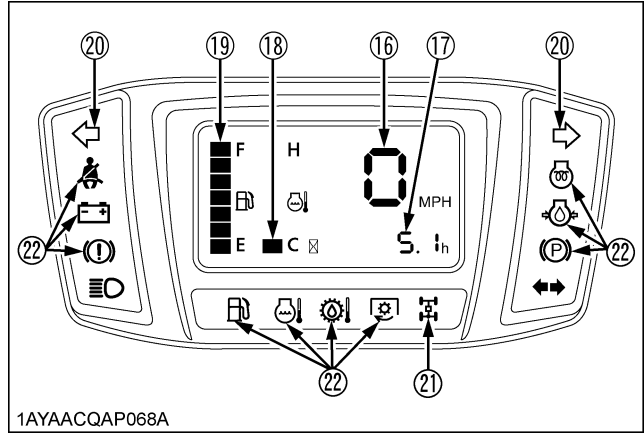
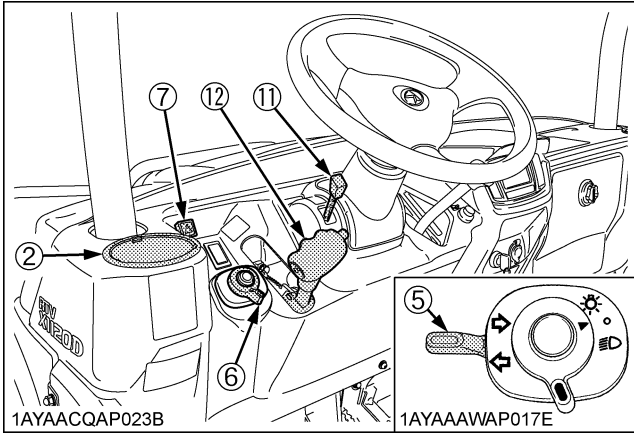

ILLUSTRATED CONTENTS

(1) Steering wheel.....	--
(2) Cup holder.....	--
(3) Horn button.....	19
(4) Key switch.....	--
(5) Turn signal light switch (if equipped).....	18
(6) Head light switch.....	18
(7) Hazard light switch (if equipped).....	18
(8) Brake pedal.....	20
(9) Speed control pedal.....	22
(10) Range gear shift lever.....	20
(11) Tilt lever (if equipped).....	17
(12) Parking brake lever.....	21

ILLUSTRATED CONTENTS

(13) 12V accessory plug.....	25
(14) Glove box cover (if equipped).....	26
(15) Liquid crystal display.....	22
(16) Speedometer.....	24
(17) Hourmeter.....	24
(18) Coolant temperature gauge.....	23
(19) Fuel gauge.....	23
(20) Turn signal indicator (if equipped) / Hazard signal indicator (if equipped).....	18, 18
(21) 4WD indicator.....	21
(22) Easy Checker(TM).....	22

[RTV-X900]

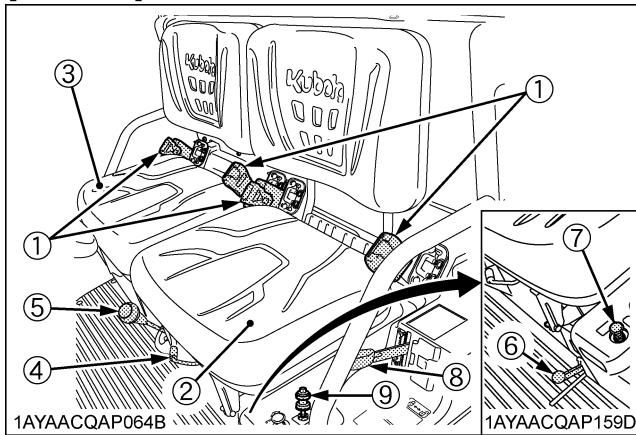

[RTV-X1120D]

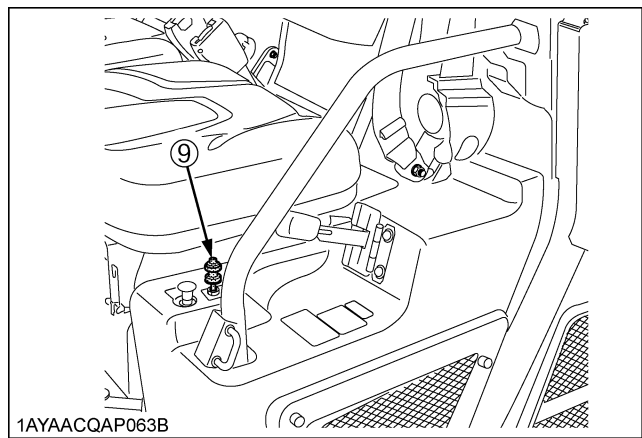
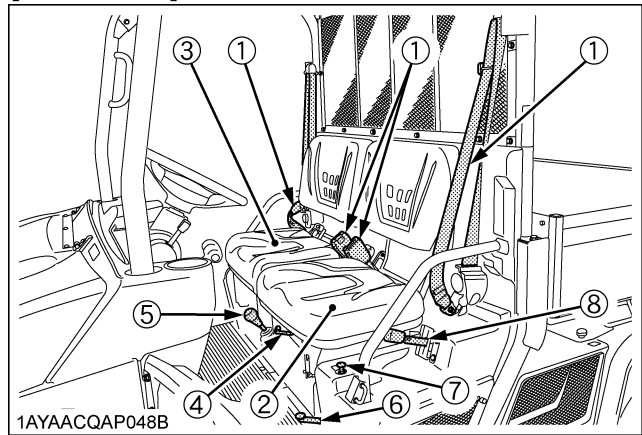

ILLUSTRATED CONTENTS

(1) Seat belts.....	17
(2) Operator's seat.....	49
(3) Passenger seat.....	49
(4) Seat slide lever (if equipped).....	17
(5) 4WD lever.....	21

ILLUSTRATED CONTENTS

(6) Differential lock pedal.....	26
(7) Differential lock holder.....	26
(8) Hydraulic lift cylinder lever (if equipped) or Hydraulic outlet lever (if equipped).....	33, 36
(9) Engine hand throttle (if equipped).....	30

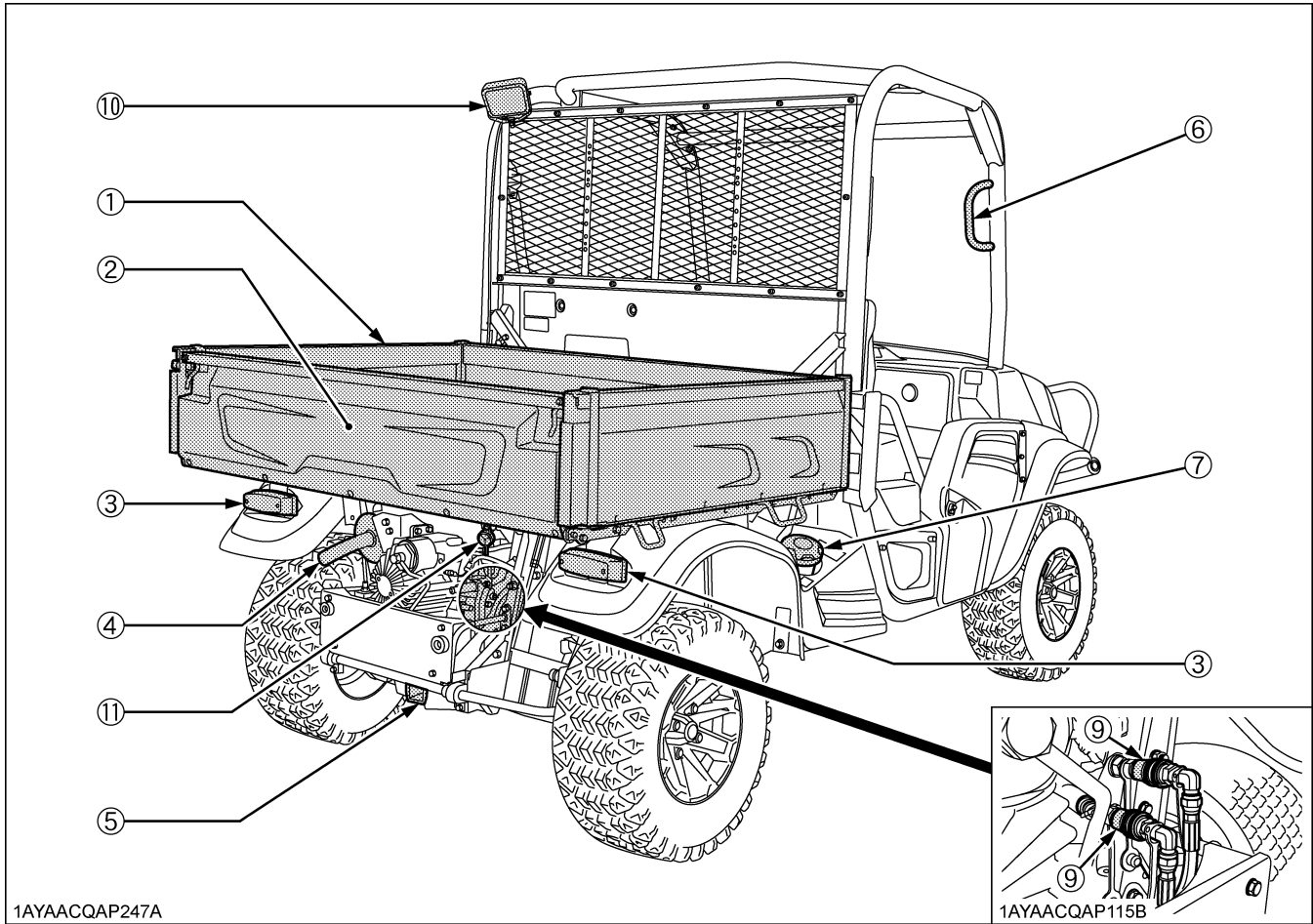

11YAACQAP247A

11YAACQAP115B

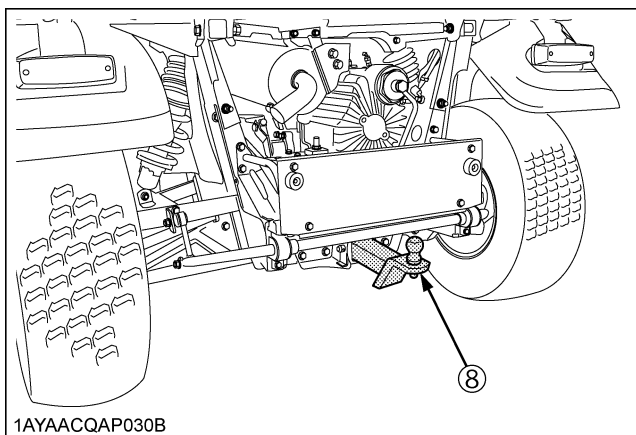

11YAACQAP030B

ILLUSTRATED CONTENTS

ILLUSTRATED CONTENTS

(1) Cargo bed.....	31
(2) Tailgate.....	33
(3) Tail lamp (Combination lamp if equipped).....	18
(4) Muffler.....	67
(5) Rear trailer hitch bracket.....	40
(6) Handgrip.....	--

(7) Fuel tank cap.....	52
(8) Rear trailer hitch (if equipped).....	40
(9) Hydraulic outlet (if equipped).....	36
(10) Rear work light (if equipped).....	19
(11) Backup beeper (if equipped).....	58

PRE-OPERATION CHECK

DAILY CHECK

To prevent trouble from occurring, it is important to know the condition of the vehicle well. Check it before starting.



WARNING

To avoid serious injury:

- **Be sure to check and service the vehicle on a level surface with the engine shut off and the parking brake "ON" and implement lowered to the ground if equipped.**

Check item

- Walk around inspection
- Check engine oil level
- Check transmission fluid level
- Check brake fluid level
- Check hydraulic tank oil level
- Clean hydraulic oil cooler net
- Check coolant level
- Clean grill, radiator screen
(When used in a dusty place)
- Check brake pedal
- Check parking brake
- Check indicators, gauges and meters
- Check lights
- Check seat belt and ROPS
- Check joint boots
- Check tire inflation pressure
- Check backup beeper (if equipped)
- Refuel
(See "DAILY CHECK" in "PERIODIC SERVICE" section.)
- Care of danger, warning and caution labels
(See "DANGER, WARNING AND CAUTION LABELS" in "SAFE OPERATION" section.)

OPERATING THE ENGINE



WARNING

To avoid serious injury:

- Read and understand "Safe Operation" in front of this manual.
- Read and understand the danger, warning and caution labels located on the vehicle.
- To avoid the danger of exhaust fume poisoning, do not operate the engine in a closed building without proper ventilation.
- Never start engine while standing on ground. Start engine only from operator's seat.
- Make it a rule to set range gear shift lever to the "NEUTRAL" position and to place the Hydraulic Outlet lever (if equipped) in "OFF" position and to place the hydraulic lift cylinder lever (if equipped) to the "NEUTRAL" position before starting the engine.
- Make sure the engine hand throttle (if equipped) is in its idle engine speed position.

IMPORTANT :

- Do not use starting fluid or ether.
- To protect the battery and the starter, make sure that the starter is not continuously turned for more than 10 seconds.

STARTING THE ENGINE

1. Make sure the parking brake is set.

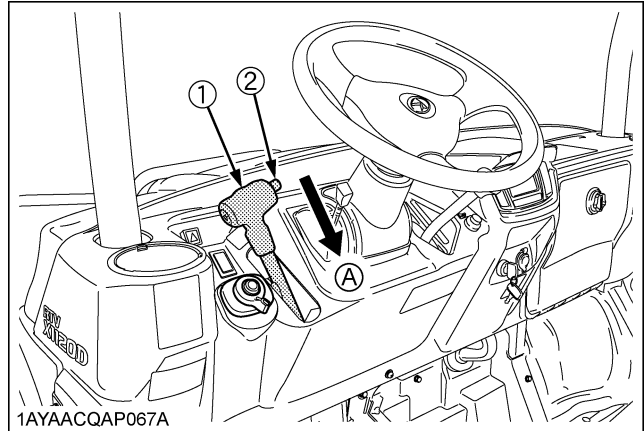

(1) Parking brake lever

(A) Pull to "PARK"

(2) Release button

2. Make sure the door is properly secured. (if equipped)
See "Locking and Unlocking the Door" in "STARTING" in "OPERATING THE VEHICLE" section.

3. Set the range gear shift lever to the "NEUTRAL" position.

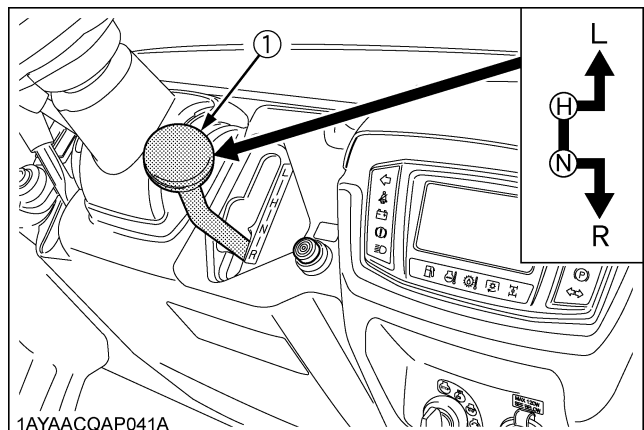

(1) Range gear shift lever

(L) LOW Range

(H) HIGH Range

(N) "NEUTRAL" POSITION

(R) "REVERSE"

4. Lock the hydraulic lift cylinder lever or the hydraulic outlet lever to the "NEUTRAL" position with a restricting plate (if equipped).

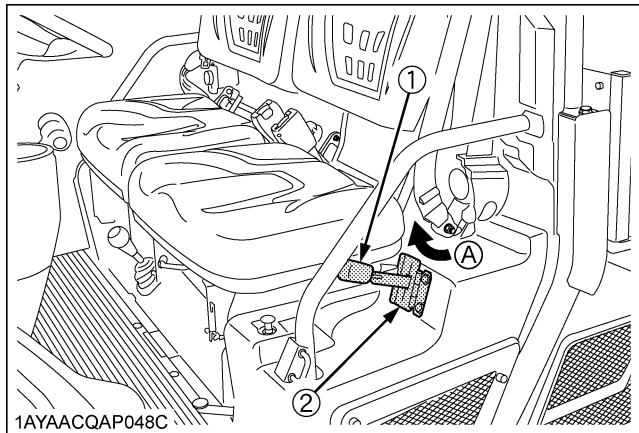

- (1) Hydraulic lift cylinder lever (if equipped) or Hydraulic outlet lever (if equipped)
 (2) Restricting plate (if equipped)

5. Push the speed control pedal down about 1/2 way.

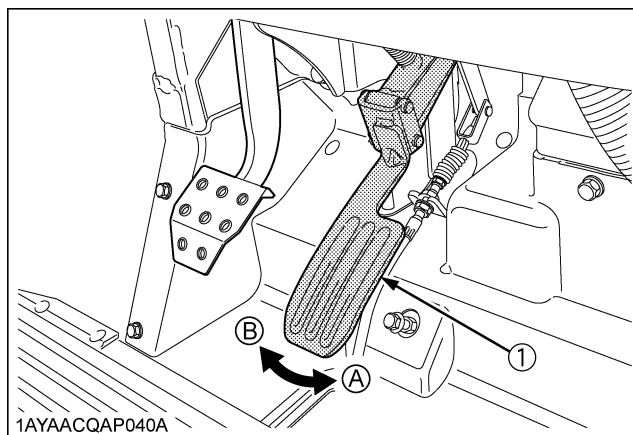

- (1) Speed control pedal
 (A) "INCREASE"
 (B) "DECREASE"

6. Insert the key into the key switch and turn it "ON".

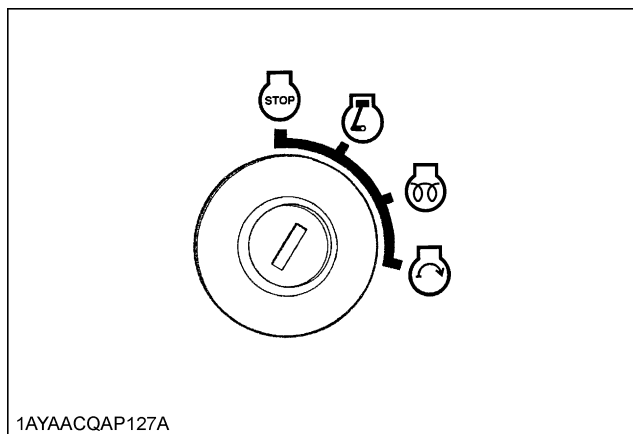

- (☰) "OFF" (Engine-Stop) (☷) "GLOW" (Preheat)
 (⌚) "ON" (Engine-Run) (🔑) "START" (Engine-Start)

NOTE :

- ON.....
- All the accessories can be used while the engine is stopped.
 - Do not leave the key at "ON" position. The battery will be quickly discharged. Turn it back to the "OFF" position after use.

◆ Easy Checker(TM) Lamps:

1. When the key is turned "ON", lamps(3)(4) should come on. If trouble should occur at any location while the engine is running, the warning lamp corresponding to that location comes on.
2. The parking brake warning lamp(1) comes on while parking brake is applied and goes off when it is released.
If the parking brake is released but the lamp stays on, it means that the brake system may be damaged.

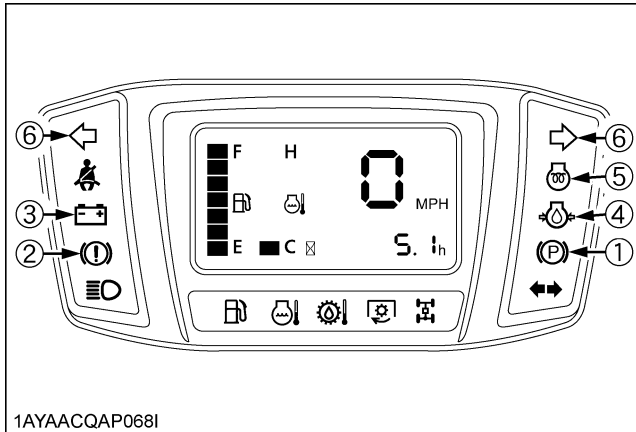

1AYAACQAP068I

- (1) Parking brake
- (2) Brake fluid
- (3) Electrical charge
- (4) Engine oil pressure
- (5) Glow plug
- (6) Hazard (if equipped) / Turn signal (if equipped)

IMPORTANT :

- Daily checks with the Easy Checker(TM) only, are not sufficient. Never fail to conduct daily checks carefully by referring to "DAILY CHECK" in "PERIODIC SERVICE" section.

7. Turn the key to "PREHEAT" position and hold it for the preheating.

For the appropriate preheating time, refer to the table below:

Temperature	Preheating Time
Over 0 °C (32 °F)	2 to 3 sec.
-5 to 0 °C (23 to 32 °F)	5 sec.
-15 to -5 °C (5 to 23 °F)	10 sec.
Limit of continuous use	30 sec.

NOTE :

- Glow plug indicator(5) comes on while key switch is in the "GLOW" position.

8. Turn the key to "START" position and release when the engine starts.

IMPORTANT :

- Because of safety devices, the engine will not start except when the range gear shift lever is placed in the "NEUTRAL" position.

■ Cold Weather Starting

When the ambient temperature is below 0 °C (32 °F) and the engine is very cold. If the engine fails to start after 10 seconds, turn off the key for 30 seconds. Then repeat steps 7 and 8. To protect the battery and the starter, make sure that the starter is not continuously turned for more than 10 seconds.

■ Engine Hand Throttle

[if equipped]

When the ambient temperature is below -15 °C (-59 °F) and the engine is very cold, pull the hand throttle to the "HIGH" position and turn the key switch to "START" position.

After the engine starts, push the hand throttle back to the "LOW" position.

■ Block Heater

[if equipped]

A block heater is available as an option from your dealer. It will assist you in starting your vehicle when the ambient temperature is below -20 °C (-4 °F).

9. Check to see that all the warning lamps on the Easy Checker(TM) are "OFF".

If any warning lamp stays on, immediately stop the engine and determine the cause.

STOPPING THE ENGINE

1. After slowing the engine to idle, turn the key to "OFF".
2. Return the engine hand throttle (if equipped) to its idle engine speed position.
3. Remove the key.

WARMING UP



WARNING

To avoid serious injury:

- Be sure to set the parking brake during warm-up.
- Be sure to set the range shift lever to the "NEUTRAL" position and lock both the hydraulic lift cylinder and the hydraulic outlet levers to the "OFF" position with restricting plate (if equipped) during warm-up.

For 5 minutes after engine start-up, allow engine to warm up without applying any load. This is to allow oil to reach every part of the engine. If load should be applied to the engine without this warm-up period, problems may develop such as seizure, breakage or premature wear may develop.

■ Warm-Up Transmission Oil in the Low Temperature Range

Hydraulic oil serves as transmission fluid. In cold weather, the oil may be cold with increased viscosity. This can cause delayed oil circulation or abnormally low hydraulic pressure for some time after engine start-up. This in turn can create problems with the hydraulic system.

To prevent the above, observe the following instructions: Warm up the engine at about 50% of rated rpm according to the table below:

Ambient temperature	Warm-up time requirement
Above 0 °C (32 °F)	Approx. 5 minutes
-10 to 0 °C (14 to 32 °F)	5 to 10 minutes
-20 to -10 °C (-4 to 14 °F)	10 to 15 minutes
Below -20 °C (-4 °F)	More than 15 minutes

IMPORTANT :

- Do not operate the vehicle under full load condition until it is sufficiently warmed up.

JUMP STARTING



WARNING

To avoid serious injury:

- Keep cigarettes, sparks, and flames away from battery.
- If vehicle battery is frozen, do not jump start engine.
- Do not connect other end of negative jumper cable to negative terminal of vehicle battery.
- The parts such as the muffler may be hot. Be careful not to get burned in connecting jumper cables.

When jump starting the engine, follow the instructions below to safely start the engine.

1. Bring helper vehicle with a battery of the same voltage as the disabled vehicle within easy cable reach. "THE VEHICLES MUST NOT TOUCH".
2. Engage the parking brake of both vehicles and put the shift lever in neutral. Shut the engine off.
3. Put on safety goggles and rubber gloves.
4. Ensure the vent caps are securely in place. (if equipped)
5. Attach the red clamp to the positive (red, (+) or pos.) terminal of the dead battery and clamp the other end of the same cable to the positive (red, (+) or pos.) terminal of the helper battery.
6. Clamp the other cable to the negative (black, (-) or neg.) terminal of the helper battery.
7. Clamp the other end to the engine block or frame of the disabled vehicle as far from the dead battery as possible.
8. Start the helper vehicle and let its engine run for a few moments. Start the disabled vehicle.
9. Disconnect the jumper cables in the exact reverse order of attachment. (Steps 7, 6 and 5).

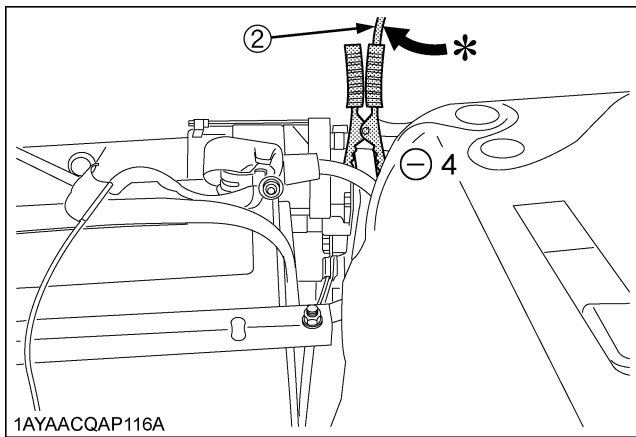
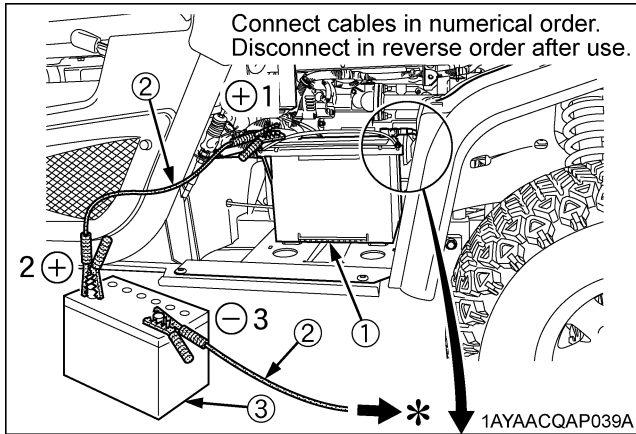

- (1) Dead battery
(2) Jumper cables
(3) Helper battery

IMPORTANT :

- This vehicle has a 12 volt negative (-) ground starting system.
- Use only same voltage for jump starting.
- Use of a higher voltage source could result in severe damage to vehicle's electrical system.
Use only matching voltage source when "Jump starting" a low or dead battery.

OPERATING THE VEHICLE

OPERATING NEW VEHICLE

How a new vehicle is handled and maintained determines the life of the vehicle.

A new vehicle just off the factory production line has been tested, but the various parts are not accustomed to each other, so care should be taken to operate the vehicle for the first 50 hours at a slower speed and avoid excessive work or operation until the various parts become "broken-in." The manner in which the vehicle is handled during the "breaking-in." period greatly affects the life of your vehicle. Therefore, to obtain the maximum performance and the longest life of the vehicle, it is very important to properly break-in your vehicle. In handling a new vehicle, the following precautions should be observed.

■ Do not Operate the Vehicle at Full Speed for the First 50 Hours

- Do not start quickly nor apply the brakes suddenly.
- In winter, operate the vehicle after fully warming up the engine.
- Do not run the engine at speeds faster than necessary.
- On rough roads, slow down to suitable speeds. Do not operate the vehicle at fast speed. The above precautions are not limited only to new vehicles, but to all vehicles. But it should be especially observed in the case of new vehicles.

■ Changing Lubricating Oil for New Vehicles

The lubricating oil is especially important in the case of a new vehicle. The various parts are not "broken-in" and are not accustomed to each other. Small pieces of metal grit may develop during the operation of the vehicle; and this may wear out or damage the parts. Therefore, care should be taken to change the lubricating oil a little earlier than would ordinarily be required. For further details of change interval hours, see "MAINTENANCE" section.

STARTING

1. Make sure the door is properly secured. (if equipped)

■ Locking and Unlocking the Door



WARNING

To avoid serious injury or death:

- Secure the doors properly.

Secure the door properly to lock. Pull up the door handle to unlock.

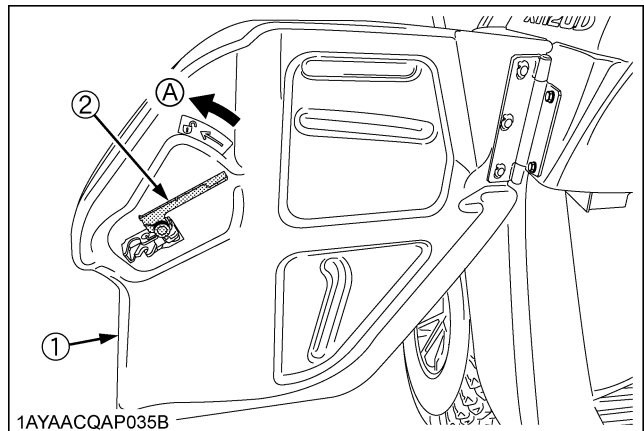

(1) Door
(2) Door handle

(A) "UNLOCK"

2. Fasten the seat belt.

■ **Seat Belt**

! WARNING

To avoid serious injury:

- **Seat belts reduce injury. Always wear your seat belts. The lap-style seat belts may not provide adequate protection for small children. Special care is recommended when carrying a child passenger. Where appropriate, use a child safety seat.**

! WARNING

To avoid serious injury:

- **Always use the seat belts when operating and riding in the vehicle.**

Adjust the seat belts for proper fit and connect the buckle. 2 point seat belt is an auto-locking retractable type. 3 point seat belt is an emergency locking retractable type.

[RTV-X900]

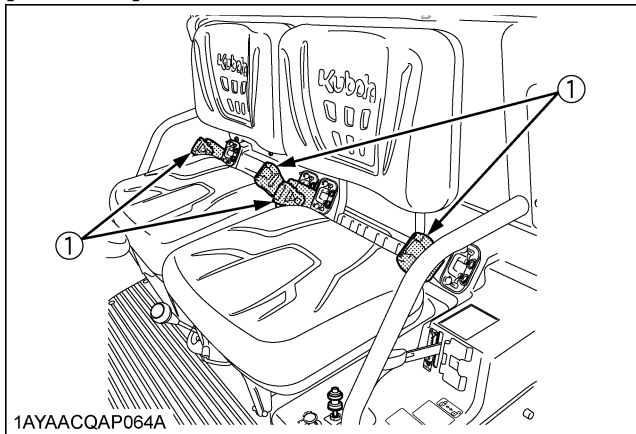

(1) Seat belt (2 point type)

[RTV-X1120D]

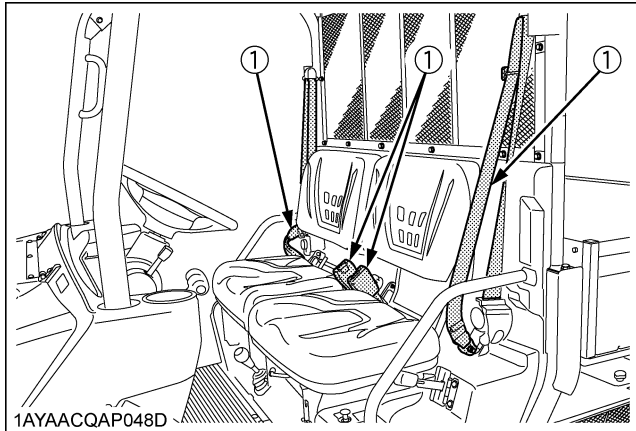

(1) Seat belt (3 point type)

3. **Adjust steering position.**

■ **Tilt Steering Wheel**

[if equipped]

Adjust the steering wheel to proper position. The steering wheel can be adjusted while the tilt lever is pulled.

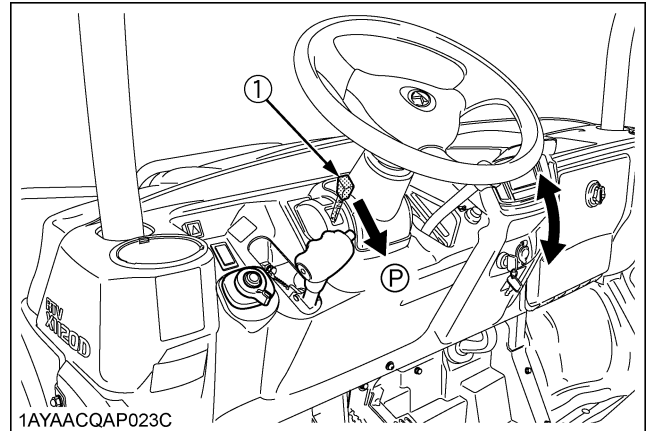

(1) Tilt lever

(P) "PULL"

4. **Adjust operator's seat.**

■ **Seat Slide Lever**

[if equipped]

Adjust the operator's seat to proper position. The operator's seat can be adjusted while the seat slide lever is pulled up.

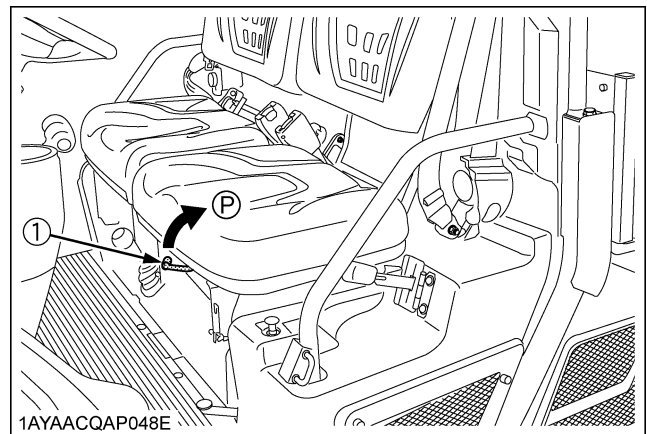

(1) Seat slide lever

(P) "PULL UP"

5. Selecting light switch position.

■ Head Light Switch

The head light switch is operative when the key switch is in the "ON" position.

Turn on the key switch and turn the head light switch clockwise to the "ON" position, the head lights light up. Turn the head light switch counterclockwise to the "OFF" position to turn off the head light.

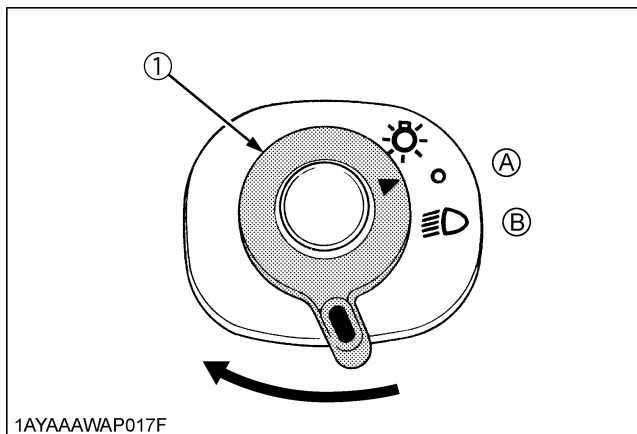

(1) Head light switch

(A) Head lights "OFF"

(B) Head lights "ON"

NOTE :

- Turning the head light switch to the "ON" position causes the following lamps to light simultaneously.
 - (1) Tail lights (lamps at the rear portions of the vehicle)

■ Hazard Light Switch

[if equipped]

Press the hazard light switch, the hazard light flash along with the indicator on the instrument panel.

Press the hazard light switch again to turn off the hazard light.

NOTE :

- The hazard light switch is operative when the key switch is in either the "ON" or "OFF" position. Be careful that leaving the switch "ON" causes the battery to run out.

■ Turn Signal Light Switch

[if equipped]

To indicate a right turn, turn the turn signal light switch clockwise.

To indicate a left turn, turn the turn signal light switch counter-clockwise.

When the left or right signal is activated, the indicated turning light will flash and the other will stay on.

The indicator lamp at the instrument panel also flashes like the above.

NOTE :

- The turn signal light switch is only operative when the key switch is in the "ON" position.
- If the hazard light switch is pressed to the "ON" position while the turn signal is activated, the indicated turning light will flash and the other will stay on.
- Be sure to return switch to center position after turning.

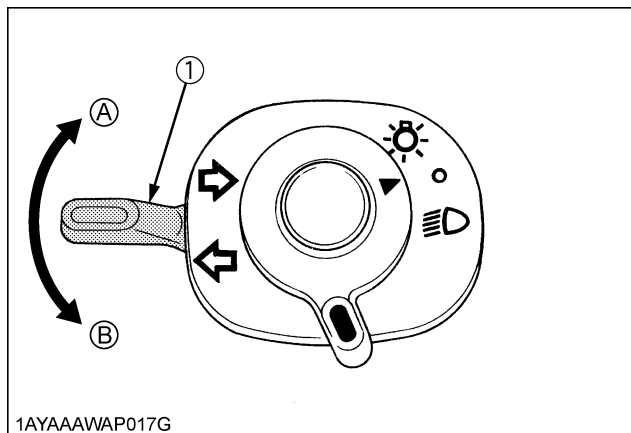

1AYAAAWAP017G

(1) Turn signal light switch

(A) "RIGHT TURN"

(B) "LEFT TURN"

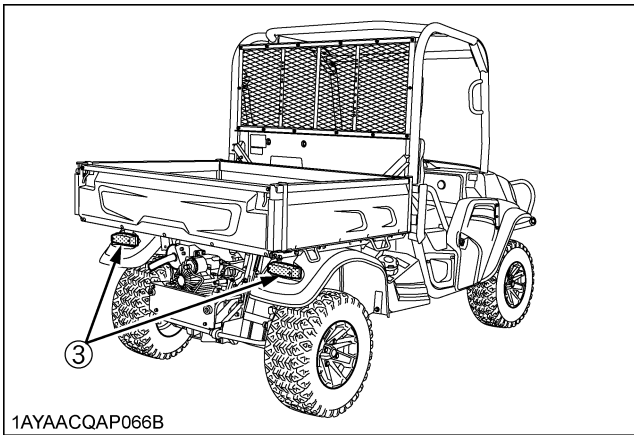
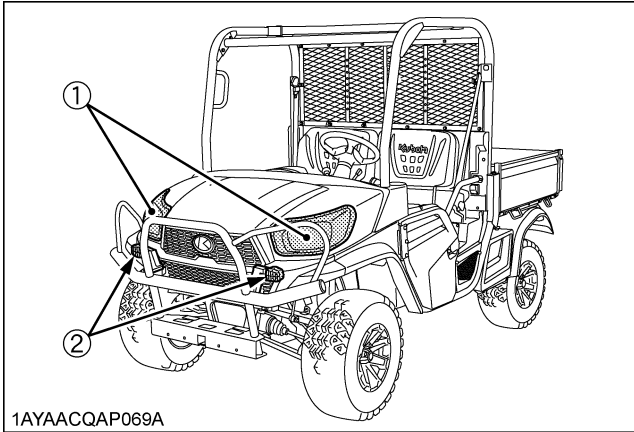

- (1) Head light
- (2) Hazard / Turn signal light (if equipped)
- (3) Tail lamp (Combination lamp if equipped)

■Horn Button

The horn switch is operative when the key switch is in either the "ON" or "OFF" position. The horn will sound when the horn button is pressed.

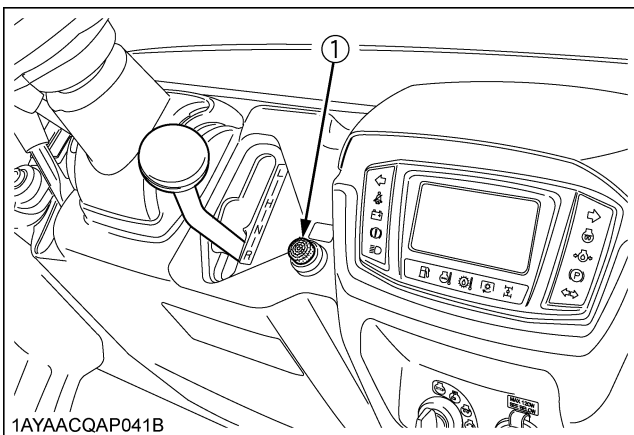

- (1) Horn button

■Work Light (Front)

[if equipped]

When the key switch is turned to the "ON" position and the front work light switch is turned to the "ON" position, the work light comes on.

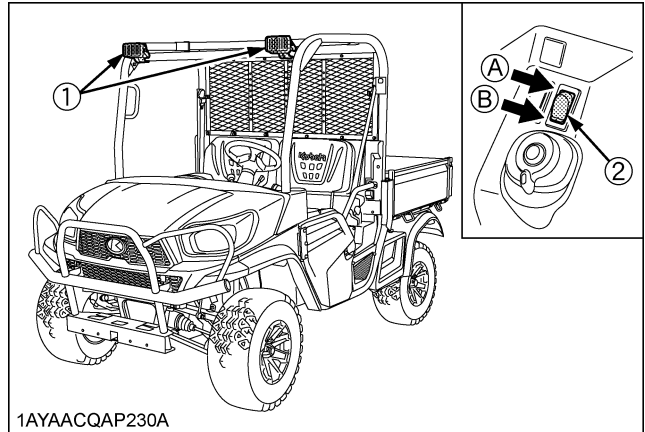

- (1) Front work light (if equipped)
- (2) Front work light switch (if equipped)
- (A) "ON"
- (B) "OFF"

■Work Light (Rear)

[if equipped]

When the key switch is turned to the "ON" position and the slide switch at the rear of each work light is slid to the "ON" position, the work light comes on. When the slide switch is slid to the "OFF" position, the light goes off.

After the slide switch for each work light is shifted to the "OFF" position, turn the key switch to the "OFF" position.

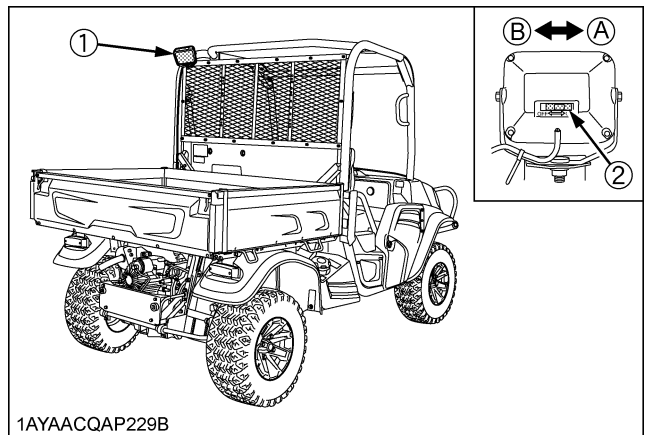

- (1) Rear work light (if equipped)
- (2) Rear work light switch (if equipped)
- (A) "ON"
- (B) "OFF"

6. Checking the brake pedal.

■ Brake Pedal



WARNING

To avoid serious injury:

- If the operator suddenly brakes, an accident may occur due to loss of control or the shifting forward of heavy loads.
- When driving on icy, wet or loose surface, operate at reduced speed to avoid skidding and loss of steering control.

The brake pedal is the left pedal on the foot board. Depress the pedal to slow or stop the vehicle.

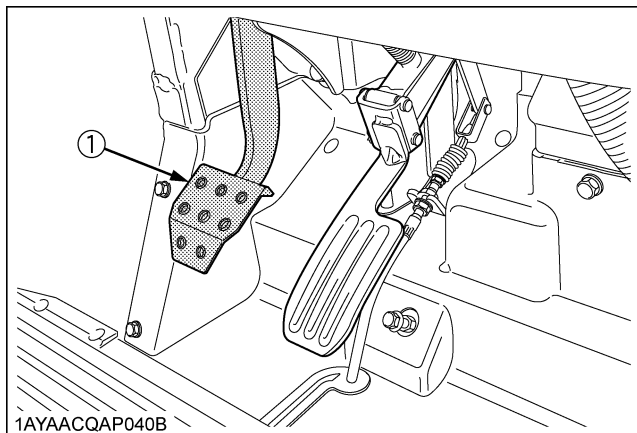

(1) Brake pedal

7. Start the engine. See "OPERATING THE ENGINE" section.

8. Selecting the travel speed.

■ Range Gear Shift Lever



WARNING

To avoid serious injury:

- Avoid changing range gear shift lever when ascending or descending a slope.
- Before ascending or descending a slope, shift to the "L" range to control the vehicle speed.
- If you shift gears while ascending or descending a slope, be prepared to use the brake to maintain control.
- Operate in reverse at slow speeds to maintain control.

1. The range gear shift lever can only be shifted when vehicle is completely stopped and the speed control pedal is in the "NEUTRAL" position.
2. To avoid transmission and shift linkage damage, completely stop the vehicle using the brake pedal before shifting gears.
3. Select proper gear and engine speed depending on the type of job.
4. Before dismounting vehicle, shift the range gear shift lever to the "NEUTRAL" position and set parking brake.

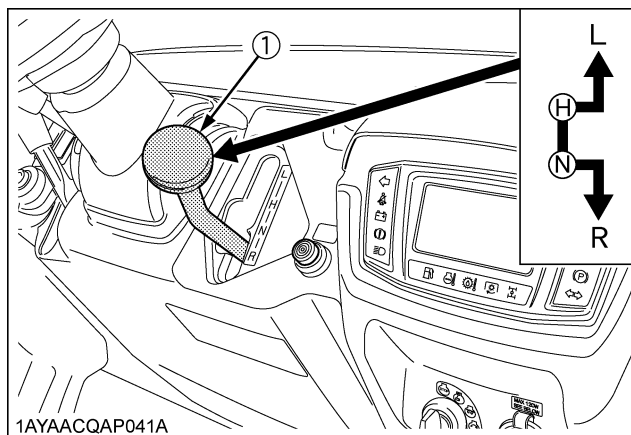

(1) Range gear shift lever

(L) LOW Range
(H) HIGH Range
(N) "NEUTRAL" POSITION
(R) "REVERSE"

NOTE :

- When range gear shift lever is hard to engage, do not force the lever. Set the parking brake, slightly depress the speed control pedal and release it to neutral position, then shift the lever.
When the lever is hard to disengage, do not force the lever.
Depress the brake pedal fully, then shift the lever.
- An accident may occur with erratic shifting operation.

- Failure to completely engage the range gear can cause the vehicle to coast on slopes.

4WD Lever



WARNING

To avoid serious injury:

- Do not engage the front wheel drive when traveling at road speed.
- When driving on icy, wet or loose surface, operate at reduced speed to avoid skidding and loss of steering control.
- An accident may occur if the vehicle is suddenly braked, such as by heavy towed loads shifting forward causing loss of control.
- The braking characteristics are different between 2 and 4 wheel drive. Be aware of the difference and use carefully.

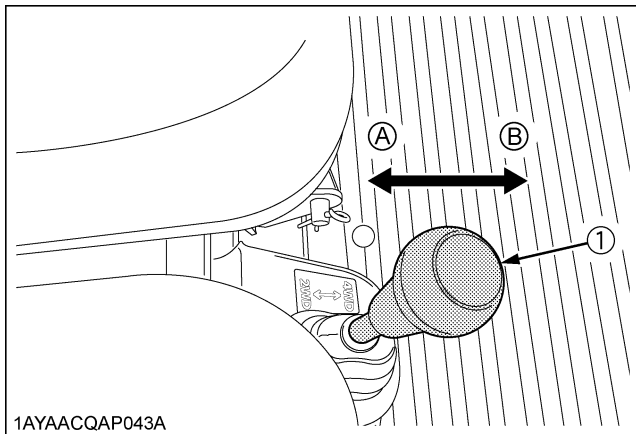

(1) 4WD lever

(A) "2WD"
(B) "4WD"

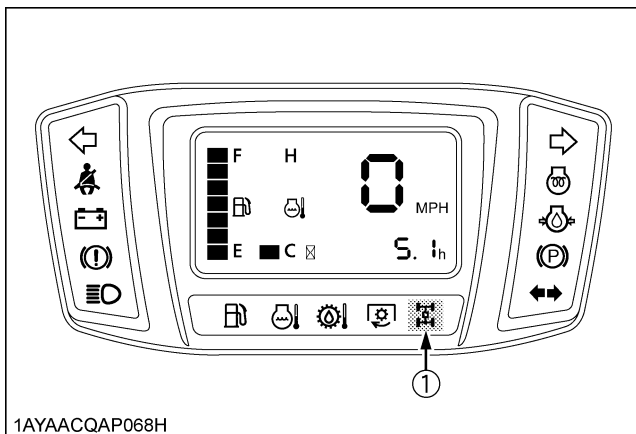

(1) 4WD indicator

IMPORTANT :

- Use the lever to engage the front wheels with the vehicle stopped. Shift the lever to "4WD" to engage the front wheel drive. When the lever is in "4WD" position, the 4WD indicator comes on.
- Tires will wear quickly if front wheel drive is engaged on paved roads.

◆ Front wheel drive is effective for the following jobs:

1. When greater pulling force is needed, such as working in a wet field, when pulling a trailer, or when working with a front-end blade.
2. When working in sandy soil.

9. Unlock the parking brake and start slowly.

■ Parking Brake Lever

To release the parking brake, depress the brake pedal, push release button and push up parking brake lever. Depressing the brake pedal makes release force smaller. Make sure that indicator in the Easy Checker(TM) goes off.

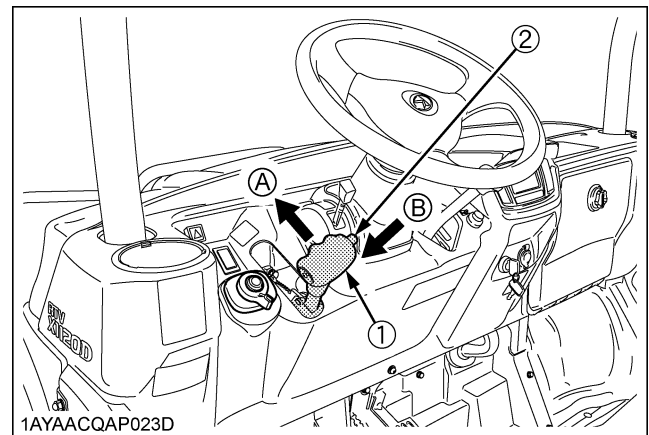

(1) Parking brake lever
(2) Release button

(A) "RELEASE"
(B) "PUSH"

■ Speed Control Pedal

Use the speed control pedal when traveling. Push down on it for higher speed.

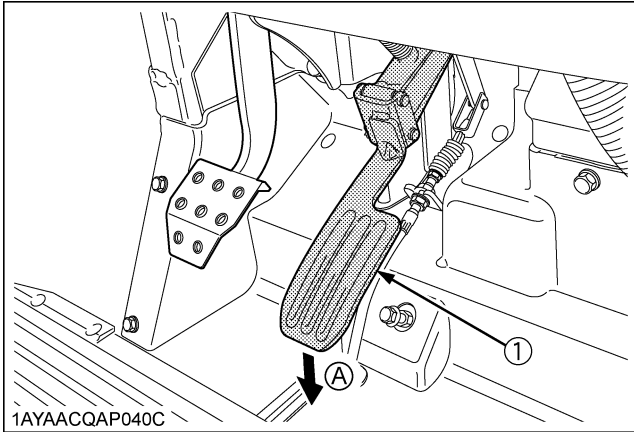

(1) Speed control pedal (A) "INCREASE"

STOPPING

■ Stopping

1. Release the speed control pedal.
2. Step on the brake pedal.
3. After the vehicle has stopped, put the range gear shift lever in neutral, and set the parking brake.

CHECK DURING DRIVING

■ Immediately Stop the Engine if:

- The engine suddenly slows down or accelerates.
- Unusual noises suddenly occur.
- Exhaust fumes suddenly become very dark.

While driving, check the following items to see that all the parts are functioning normally.

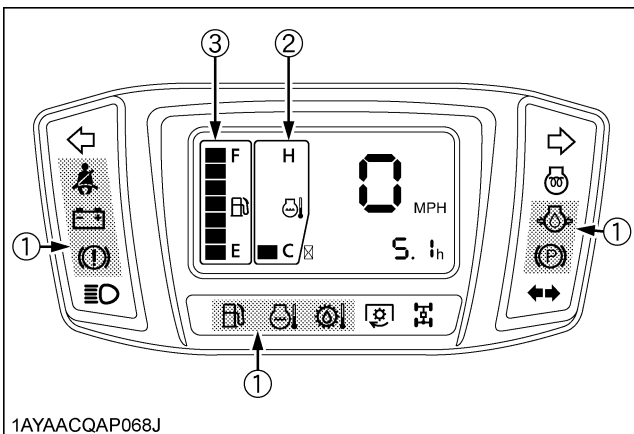

(1) Easy Checker(TM)
 (2) Coolant temperature gauge
 (3) Fuel gauge

■ Easy Checker(TM)

If the warning lamps in the Easy Checker(TM) come on during operation, immediately stop the engine, and find the cause as shown below.

Never operate the vehicle with an Easy Checker(TM) lamp on.

⚠ Engine oil pressure

If the oil pressure in the engine goes below the prescribed level, the warning lamp in the Easy Checker(TM) will come on.

If this should happen during operation, and it does not go off when the engine is accelerated, check level of engine oil.

(See "Checking Engine Oil Level" in "DAILY CHECK" in "PERIODIC SERVICE" section.)

⚠ Electrical charge

If the alternator is not charging the battery, the Easy Checker(TM) will come on.

If this should happen during operation, check the electrical charging system or consult your local KUBOTA Dealer.

⚠ Low brake fluid level

If the brake fluid goes below the prescribed level, the warning lamp in the Easy Checker(TM) will come on. If this should happen during operation, check to see that there is no oil leak in the brake system, and then add Dot3 brake fluid.

(See "Checking Brake Fluid Level" in "DAILY CHECK" in "PERIODIC SERVICE" section.)

⚠ VHT oil temperature

If the VHT oil is overheated, the warning lamp will come on and the buzzer will sound.

Check the vehicle by referring to "TROUBLESHOOTING" section.

Ⓟ Parking brake

If the parking brake indicator is on during operation, release the parking brake lever immediately.

The parking brake indicator in the Easy Checker(TM) comes on if the parking brake is applied.

⚠ Seat belt [RTV-X1120D only]

With the key switch "ON", when the operator or passenger does not fasten the seat belt, seat belt warning lamp comes on.

■ Fuel Gauge

Park the vehicle on a flat place.

When the key switch is "ON", the fuel gauge indicates the fuel level.

Be careful not to empty the fuel tank. Otherwise air may enter the fuel system.

Should this happen, the system should be bled. (See "Bleeding Fuel System" in "SERVICE AS REQUIRED" in "PERIODIC SERVICE" section.)

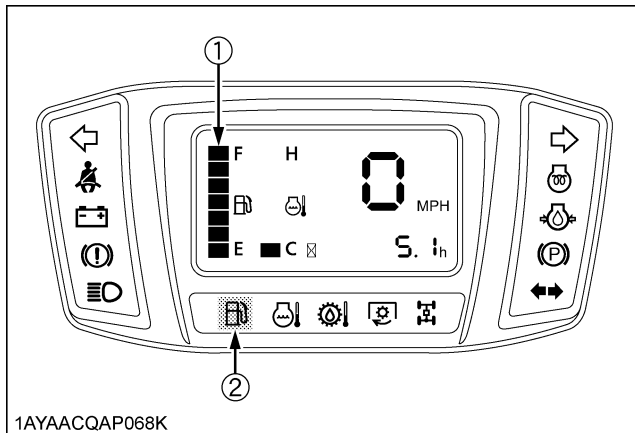

1AYAACQAP068K

- (1) Fuel gauge
(2) Fuel level warning lamp

■ Coolant Temperature Gauge



WARNING

To avoid serious injury:

- Do not remove radiator cap until coolant and engine temperature has cooled. Then loosen cap slightly to the stop to relieve any pressure before removing cap completely.

1. With the key switch "ON" the coolant temperature gauge indicates the temperature of the coolant.
2. If the engine is overheated, the warning lamp will come on and the buzzer will sound. Check the vehicle by referring to "TROUBLESHOOTING" section.

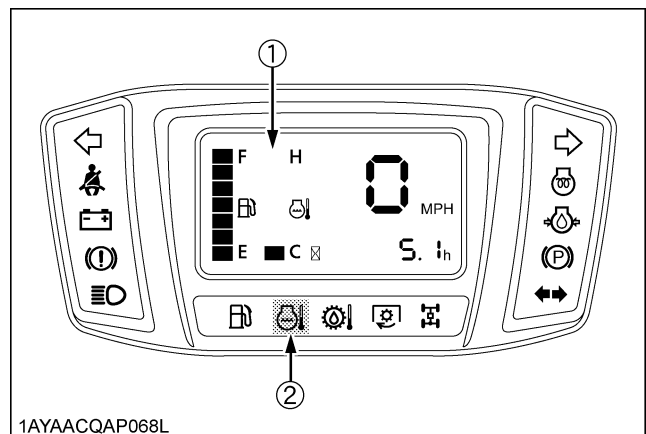

1AYAACQAP068L

- (1) Coolant temperature gauge
(2) Overheat warning lamp

IMPORTANT :

- If the engine overheat and VHT overheat occur together, do not stop the engine. When it is safe to do so, remove the engine load and keep the engine idling to allow cool down to occur. After the warning lamps go off, wait for 5 minutes, and stop the engine. See "TROUBLESHOOTING" section.

Hourmeter and Odometer

When the key is turned to the "ON" position and the engine is not running, the hourmeter is displayed.

When the key is the "ON" position and the engine is running, the odometer is displayed.

The hourmeter indicates in 5 digits the hours the vehicle has been used; the last digit indicates 1/10 of an hour.

The odometer indicates in 5 digits the distance the vehicle has been used; the last digit indicates 1/10 of a mile.

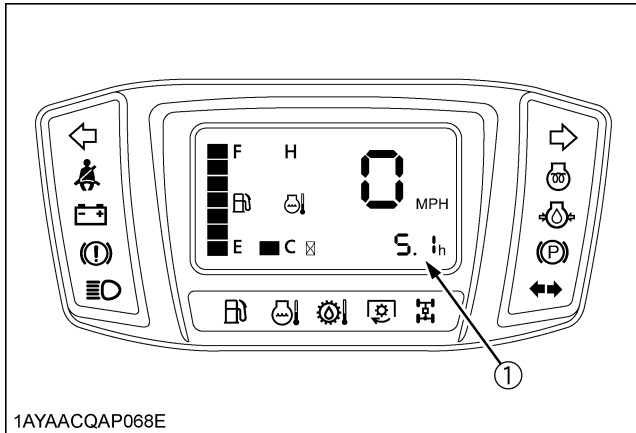

(1) Hourmeter

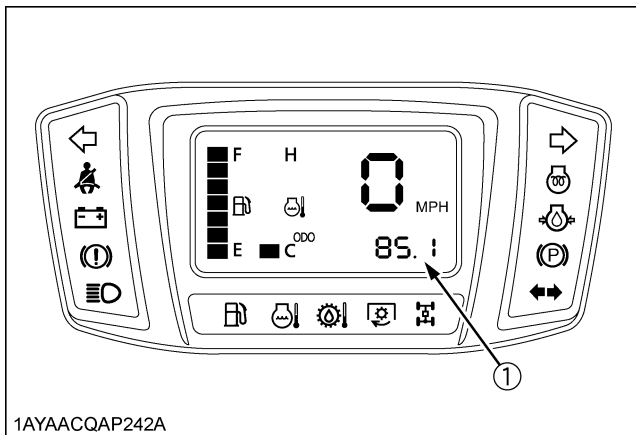

(1) Odometer

Speedometer

The speedometer indicates the traveling speed.

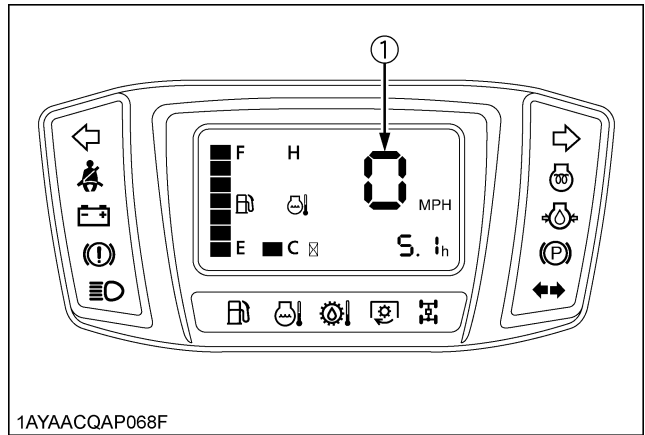

(1) Speedometer

PARKING

■ Parking Brake Lever



WARNING

To avoid serious injury:

BEFORE DISMOUNTING VEHICLE

- ALWAYS SET PARKING BRAKE AND LOWER ALL IMPLEMENTS TO THE GROUND.
Leaving transmission in gear with the engine stopped will not prevent vehicle from rolling.
- STOP THE ENGINE AND REMOVE THE KEY.

1. Stop the vehicle on a level surface.
2. To set the parking brake, depress the brake pedal and pull the parking brake lever to the rear engaged position.
3. To release the parking brake, depress the brake pedal, push release button and push up parking brake lever. Depressing the brake pedal makes release force smaller. Make sure that indicator in the Easy Checker(TM) goes off.

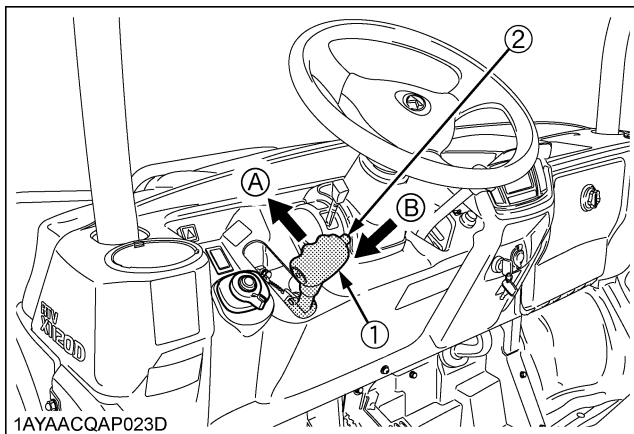

(1) Parking brake lever
(2) Release button

(A) "RELEASE"
(B) "PUSH"

IMPORTANT :

- If the vehicle is operated with the parking brake applied, the brake will be damaged.

ACCESSORY

■ 12V Electric Outlet

The 12 volt power point is located on the front-panel. An auxiliary light or other devices may be connected to this outlet.

- ◆ This outlet is powered when the key switch is in either the "ON" or "OFF" position.

Remove accessory when not in use to avoid battery drain down.

- ◆ Do not connect a light or other device that draws more than 120 watts to this power point, or the battery may discharge very rapidly or the outlet may fail.

IMPORTANT :

- Do not use as a cigarette lighter.
- Do not use when wet.
- Make sure that the cap is closed when the outlet is not used.

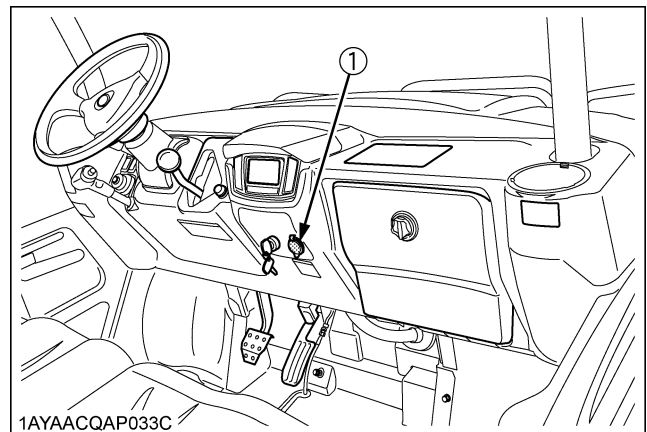

(1) 12V electric outlet

■ Utility Box

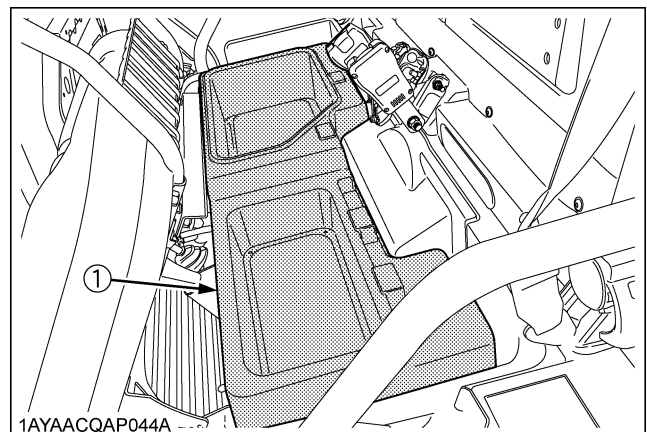

(1) Utility Box

■Glove Box (Std.) and Glove Box Cover (if equipped)

Insert the key into the knob slot and turn it counterclockwise to lock.

Insert the key into the knob slot and turn it clockwise to unlock.

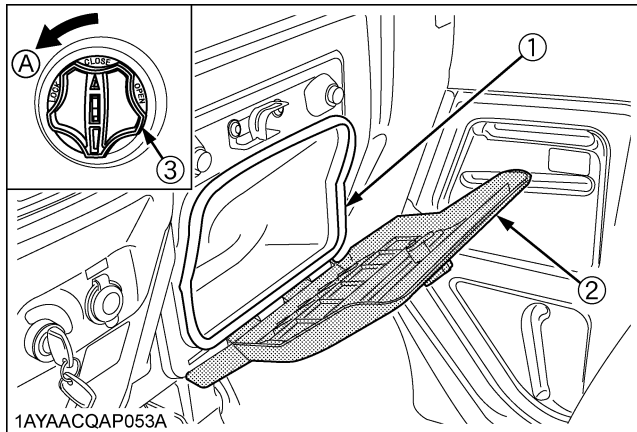

- (1) Glove box
 (2) Glove box cover (if equipped)
 (3) Knob (if equipped)

(A) "LOCK"

OPERATING TECHNIQUES

■Differential Lock



WARNING

To avoid serious injury due to loss of steering control:

- Do not operate the vehicle at high speed with differential lock engaged.
- Do not attempt to turn with the differential lock engaged.
- Be sure to release the differential lock before making a turn in field conditions.

If one of the rear wheels should slip, step on the differential lock pedal. Both wheels will then turn together, reducing slippage.

Differential lock is maintained while the pedal is depressed or may be held by using differential lock holder.

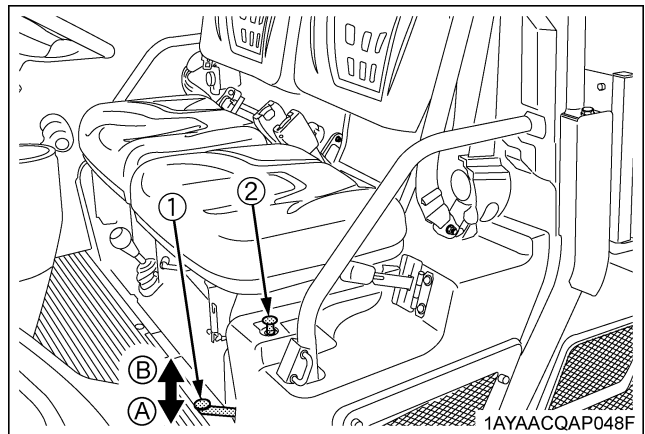

- (1) Differential lock pedal
 (2) Differential lock holder

- (A) Depress to "ENGAGE"
 (B) Release to "DISENGAGE"

◆ Handling the retaining device for differential lock

1. Pull the differential lock holder up while the differential lock pedal is depressed.
2. Release the pedal before your hand leaves the differential lock holder.
The differential lock is then maintained even if your foot leaves the pedal.
3. The lock is released when the foot pedal is depressed again.

IMPORTANT :

- When using the differential lock, always slow the vehicle and engine down.
- To prevent damage to power train, do not engage differential lock when one wheel is spinning and the other is completely stopped.

■ Directions for Use of Power Steering

1. Power steering is activated only while the engine is running. While the engine is stopped, the vehicle functions in the same manner as vehicle without power steering.
2. When the steering wheel is turned all the way to the stop, the relief valve is activated. Do not hold the steering wheel in this position for a long period of time.
3. Avoid turning the steering wheel while the vehicle is stopped, otherwise tires may wear out sooner.
4. The power steering mechanism makes the steering easier. Be careful when driving at high speeds.
5. Do not operate the hydraulic lift cylinder lever (or hydraulic outlet lever) when driving. Otherwise loss of control or failure of the power steering could occur.

■ Unfamiliar Terrain



WARNING

To avoid serious injury:

- Be sure to check for hidden obstacles or hazards before driving in a new area.
- Keep your speed down until you know the area well.
- Use existing trails and stay away from hazardous areas such as steep, rocky slopes or swamps.
- Be cautious when visibility is limited, as you may not be able to see obstacles in your path.

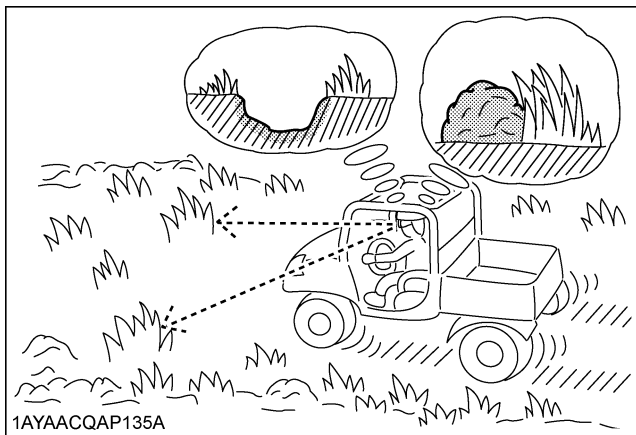

■ Driving in Reverse



WARNING

To avoid serious injury:

- Turn around, look down and behind you before backing up to be sure there are no obstacles or people in your way.
- Depress speed control pedal gradually and back cautiously.
- To stop while driving in reverse take your foot off the speed control pedal and gradually apply the brake.
- Do not suddenly engage the brake.

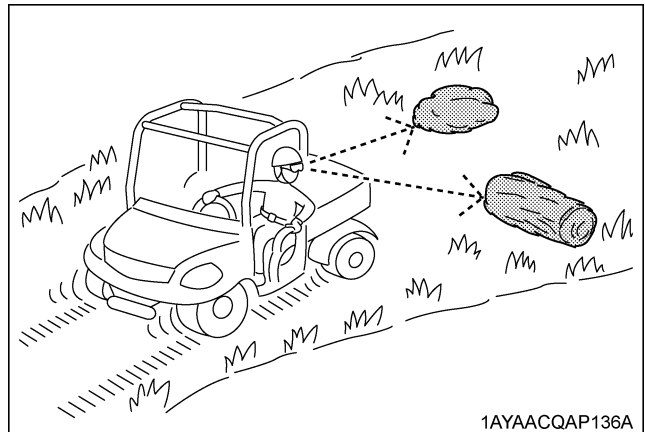

■ Driving in "4WD"

! WARNING

To avoid serious injury:

- Do not drive in "4WD" on paved surfaces.

For the maximum traction, shift the range gear shift lever into low range and use "4WD" on steep slopes or when stuck in the mud, with differential locked if necessary.

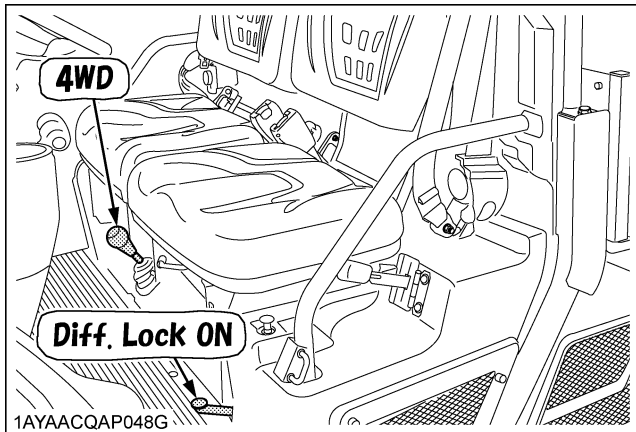
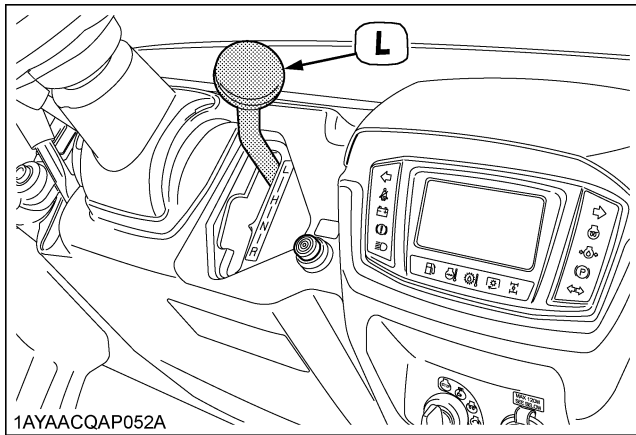
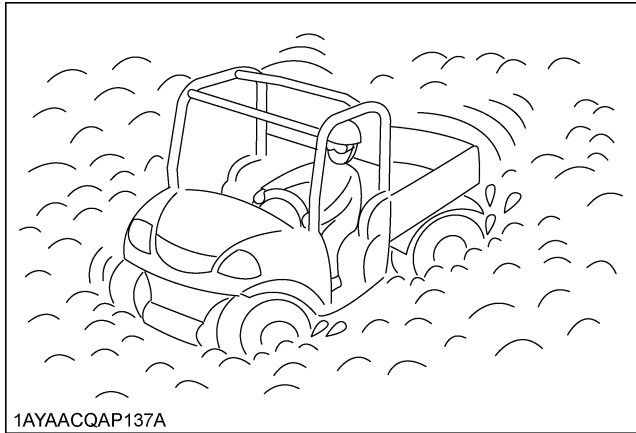

■ Turning the Vehicle

! WARNING

To avoid serious injury:

- Reduce vehicle speed before entering the turn and maintain an even speed through the turn.
- Do not make sharp turns in order to avoid loss of control or tipping.

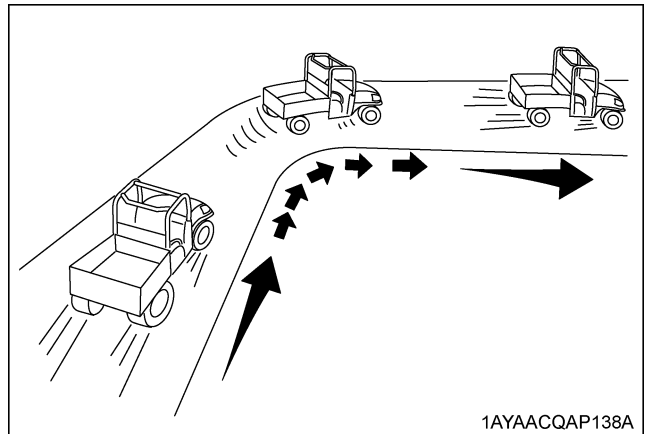

■ Hills



WARNING

To avoid serious injury:

- Do not turn sideways on a hill, or the vehicle may roll over.
- Always go straight up or down the hill.
- Slow down until you can get a clean view of the other side at the crest of a hill.
- If the engine stalls on a steep slope, roll slowly straight down, using the brake.
- Stop and look for obstacles before descending a hill.

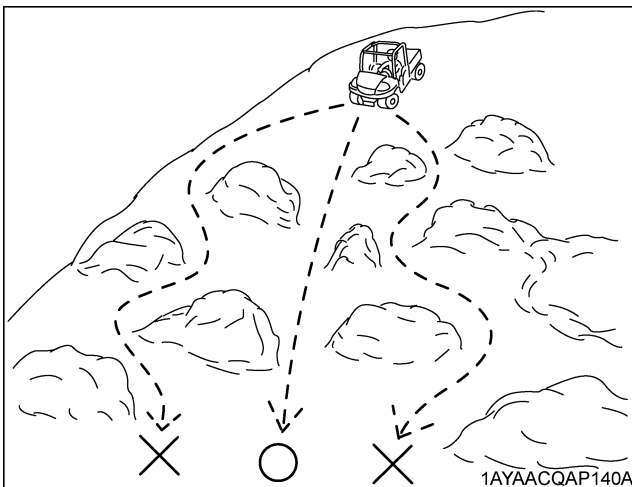
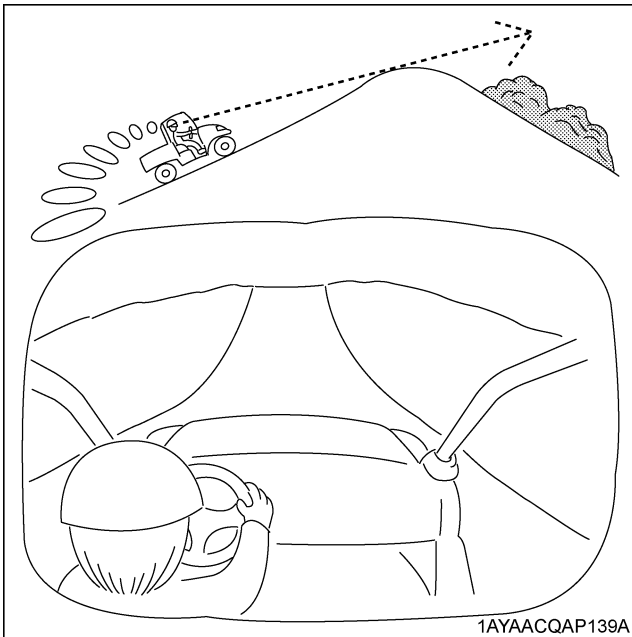

■ Traversing Hillsides



WARNING

To avoid serious injury:

- Reduce vehicles speed to prevent tipping or loss of control.
- Do not traverse hillsides that are slippery or covered with rocks or obstacles which may cause you to tip over.

■ Sliding and Skidding



WARNING

To avoid serious injury:

- Drive slowly and carefully when you are unsure or unprepared for the surface.
- Do not apply heavy braking force or accelerate when skidding to prevent loss of control.
- Use 4WD and maintain low speeds on areas covered with clay, mud, ice or snow to prevent uncontrolled skidding.

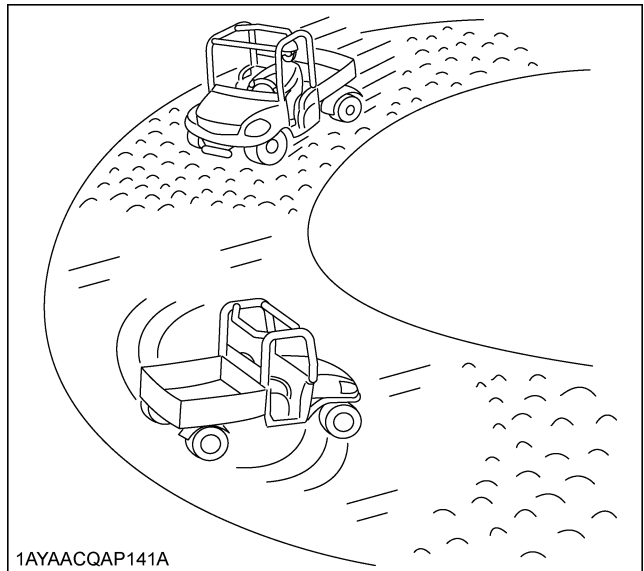

■ Driving through Water



WARNING

To avoid serious injury:

- Do not drive through water whenever it is possible.
- Drive slowly across shallow water and choose a location to enter and exit the water where the banks are not too steep or slippery.
- Before entering water, check for rocks, holes or other obstacles that may cause overturn, stuck or submerged.
- Never operate the vehicle in the fast flowing water or in water deeper than the bottom edge of the axle caps.

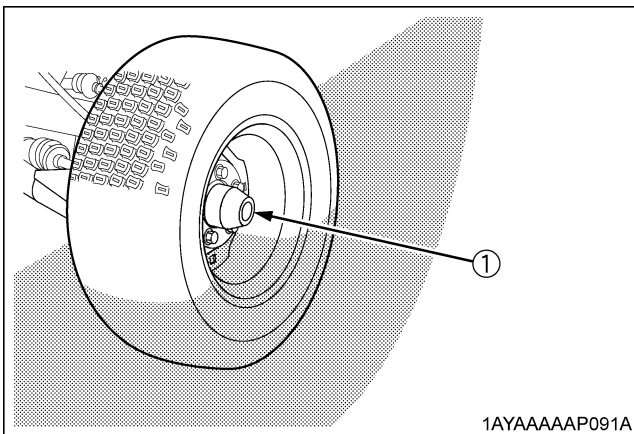
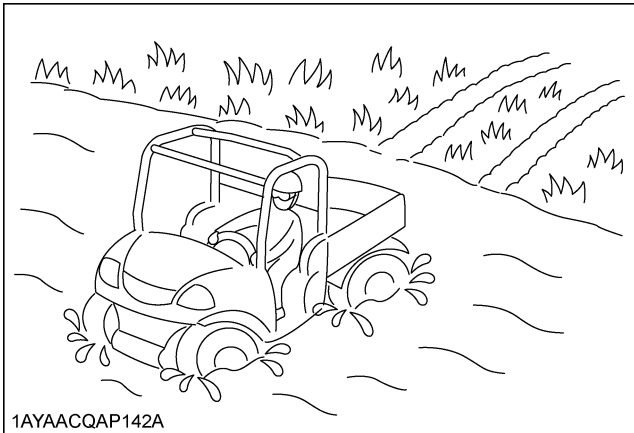

(1) Axle cap

OPERATING HAND THROTTLE

[if equipped]

- Pull the hand throttle while pushing the button, and the engine speed increases.
- Push the hand throttle while pushing the button, and the engine speed decreases.
- Fine-tune engine speed by turning the hand throttle.

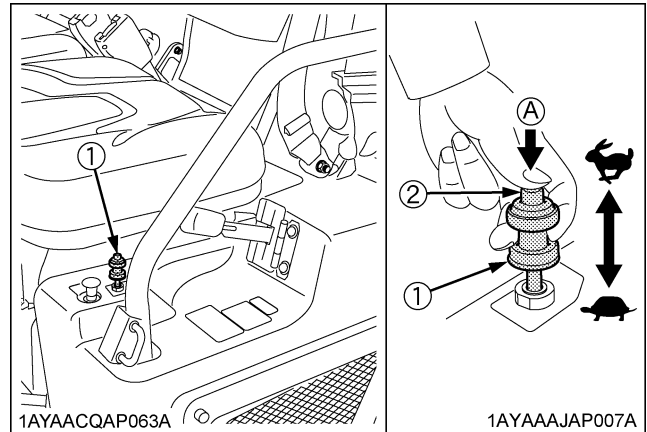

- (1) Hand throttle (if equipped)
(2) Button

- (A) "PUSH"
"HIGH"
"LOW"

IMPORTANT :

- Do not use the hand throttle while driving the vehicle, always push the hand throttle back to the "LOW" position.
Before driving the vehicle, confirm the hand throttle to be positioned to the "LOW" position.

STATIONARY HYDRAULIC OUTLET

[if equipped]

To use the hydraulic outlet system, start the hydraulic outlet system in the following steps.

1. Apply the parking brake and place chocks at the tires.
2. Make sure the shift levers are in "NEUTRAL", and start the engine.
3. Operate the hydraulic outlet lever.
(See "HYDRAULIC OUTLET" in "HYDRAULIC OUTLET" section.)
4. Set the engine speed to provide recommended fluid rate. (Refer to the implement operator's manual.)

IMPORTANT :

- Do not use a hydraulic implement which has a hydraulic motor except those approved by Kubota.

CARGO BED

CARGO BED

■ General Caution



WARNING

To avoid serious injury:

- Never carry passengers in the cargo bed. They can be tossed about or even thrown off causing serious injury or death.
- Never raise the cargo bed when it is loaded. (There is an exception. Only the vehicle equipped with hydraulic dump may do this operation at operator's seat after appropriate confirmation of safety.)
- Driving with the cargo bed tilted may be hazardous.
Always lower the bed and lock the hydraulic lift cylinder lever (if hydraulic dump is equipped) or latch the bed (if hydraulic dump is not equipped) before driving.
- Be careful not to put any part of your body, such as hands or arms, between the bed and vehicle.
- Drive slowly when it is loaded.

■ Max. Cargo Load

Never carry loads exceeding cargo bed capacity and the Permissible Cargo Load (PCL).

PCL = PC - (operator + passenger + opt. + acc. + cabin) weight

CBC (Cargo bed capacity): 500 kg (1100 lbs.)

PC: Payload Capacity

OP: Operator

PA: Passenger

opt.: option









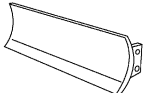

acc.: accessory

cabin: 125 kg (275 lbs.)

[Payload Capacity (PC)]

Model	RTV-X900		RTV-X1120D
	General Purpose model	Worksite model	Worksite model
Payload capacity	755 kg (1664 lbs.)	725 kg (1598 lbs.)	685 kg (1510 lbs.)

[Quick Reference Table for Cargo Load]

Model	Occupant *1	opt. + acc. (W)	Cargo bed capacity	Permissible cargo load
RTV-X900	 OP 95 kg (209 lbs.)	 Blade weight	500 kg (1100 lbs.)	[ROPS type] 660 kg (1460 lbs.) - W [Cabin type] 535 kg (1180 lbs.) - W
	 +  = 190 kg (418 lbs.) 95 kg (209 lbs.) 95 kg (209 lbs.)			[ROPS type] 565 kg (1250 lbs.) - W [Cabin type] 440 kg (970 lbs.) - W
	 OP 95 kg (209 lbs.)	+		[ROPS type] 630 kg (1390 lbs.) - W [Cabin type] 505 kg (1110 lbs.) - W
	 +  = 190 kg (418 lbs.) 95 kg (209 lbs.) 95 kg (209 lbs.)	 Winch weight		[ROPS type] 535 kg (1180 lbs.) - W [Cabin type] 410 kg (904 lbs.) - W
RTV-X1120D	 OP 95 kg (209 lbs.)	+	other opt. and acc. weight	[ROPS type] 590 kg (1300 lbs.) - W [Cabin type] 465 kg (1030 lbs.) - W
	 +  = 190 kg (418 lbs.) 95 kg (209 lbs.) 95 kg (209 lbs.)			[ROPS type] 495 kg (1090 lbs.) - W [Cabin type] 370 kg (816 lbs.) - W

*1: The calculation was made provided that the operator and the passenger weigh 95 kg each.

IMPORTANT :

- Cargo load should not exceed Cargo bed capacity and Permissible cargo load.

■ Cargo Bed Tailgate



WARNING

To avoid serious injury:

- Do not apply a load to the tailgate while the tailgate is open, as the wire loop may break, resulting in injury or loss of load.
- Do not place fingers or hands between the tailgate and the arm (latch) when closing, or fingers or hands may be pinched.

For loading and unloading, the tailgate of the cargo bed can be opened.

The tailgate is held level to the cargo bed floor with wire loops.

Do not move the vehicle with the tailgate fully lowered.

1. Raise the arms (latch) at each end of the tailgate and open the tailgate.
2. Close the tailgate by lifting it and pushing it firmly closed. Push the arms (latch) down to make sure the latches stay securely closed.

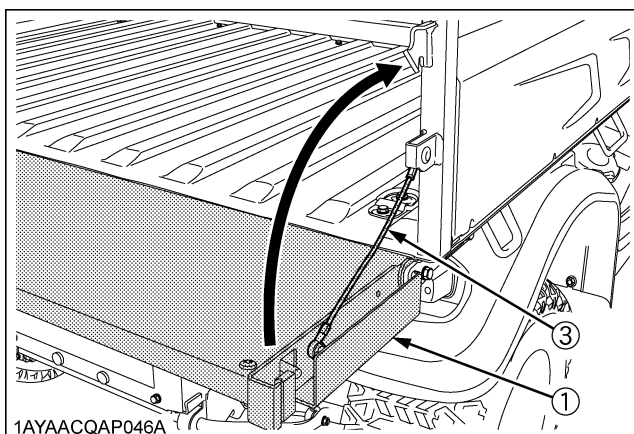
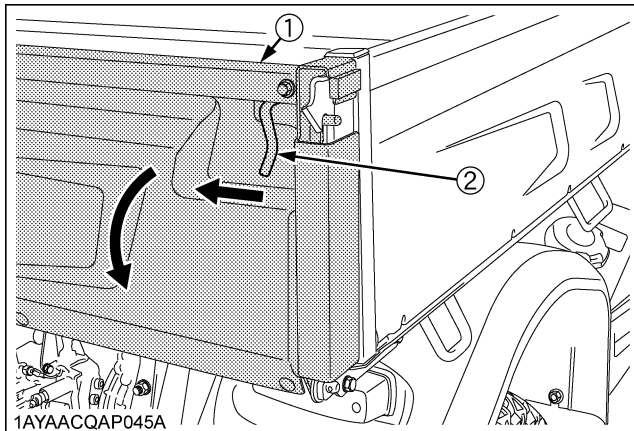

(1) Tailgate (2) Arm (latch) (3) Wire loop

IMPORTANT :

- TO AVOID TAILGATE DAMAGE:
Remove the rear trailer hitch when wire loop is removed and cargo bed is raised.

■ Raising and Lowering the Cargo Bed

[if hydraulic dump is equipped]



WARNING

To avoid serious injury:

- Make sure the vehicle is on a firm, level surface and the parking brake is applied before raising the cargo bed.
- If the vehicle is facing uphill with cargo bed raised, the weight of the cargo bed may cause the vehicle tip.
- When servicing under raised bed with lift cylinder, make sure safety support is properly mounted.
- Do not operate the hydraulic lift cylinder lever (or hydraulic outlet lever) when driving. Otherwise loss of control or failure of the power steering could occur.

◆ To raise the cargo bed

1. Start engine.
2. Release the restricting plate.
3. Pull up the hydraulic lift cylinder lever to raise the cargo bed.
4. Return the hydraulic lift cylinder lever to the "NEUTRAL" position immediately after raising the cargo bed.
5. Mount the safety support.

◆ To mount the safety support

1. Push the safety support and take off it from the hook.
2. Turn the safety support to set.

◆ To lower the cargo bed

1. Remove the safety support.
2. Shift the hydraulic lift cylinder lever to the "DOWN" position and then lower the cargo bed.
3. After making sure that the bed has been lowered to the lowest position, return the lever to the "NEUTRAL" position and then lock the lever with the restricting plate.

IMPORTANT :

- Do not hold the lever in the "UP" or "DOWN" position once the remote cylinder has reached the end of its stroke, as this will cause oil to flow through the relief valve. Forcing oil through the relief valve for extended periods will overheat the oil.
- Continuing to use the lever may cause oil temperature to rise excessively. The use of oil at a high temperature causes the seals to become damaged and fail.

◆ Using the "FLOAT" position

1. If the cargo bed cannot be raised or lowered due to trouble with the engine or hydraulic system, shift the lever to the "FLOAT" position. The cargo bed can be raised or lowered manually.

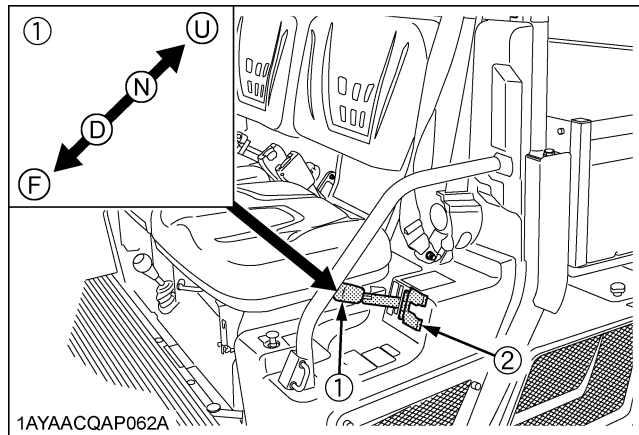

- | | |
|--|-------------------------|
| (1) Hydraulic lift cylinder lever
(if equipped) | (U) "UP" |
| (2) Restricting plate (if equipped) | (N) "NEUTRAL" |
| | (D) "DOWN" |
| | (F) "FLOAT with Detent" |

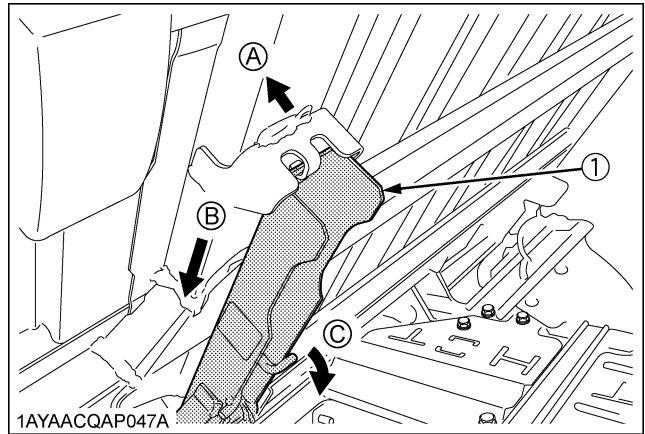

- | | |
|--------------------|--------------|
| (1) Safety support | (A) "UNLOCK" |
| | (B) "MOVE" |
| | (C) "TURN" |

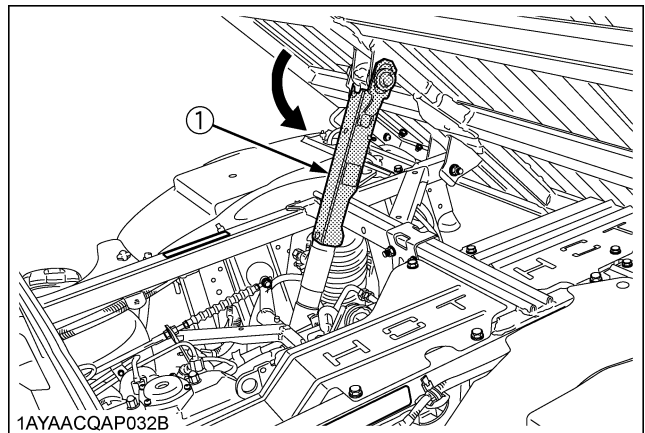

- (1) Safety support

■ Raising and Lowering the Cargo Bed [without hydraulic dump]



WARNING

To avoid serious injury:

- Always lower and latch the bed before driving.
- Be careful not to catch any part of your body, such as hands or arms, between the bed and vehicle frame when lifting and lowering the bed. To prevent injury, use only the handgrips provided.

The cargo bed may be tilted by releasing the latches on each side, and then lifting the bed with the handgrips. Support the bed in the raised position with the safety support.

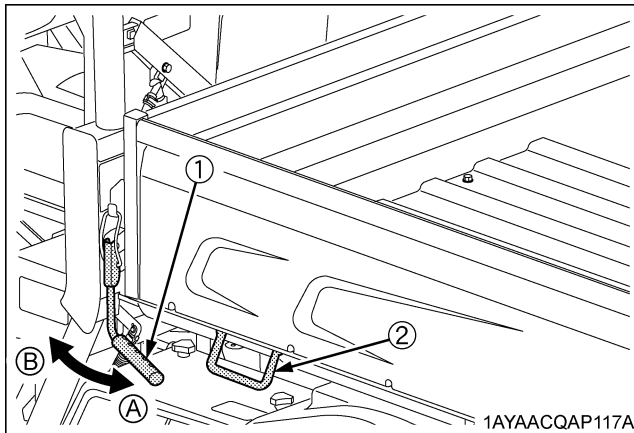

(1) Latch
(2) Handgrip

(A) "LOCK"
(B) "RELEASE"

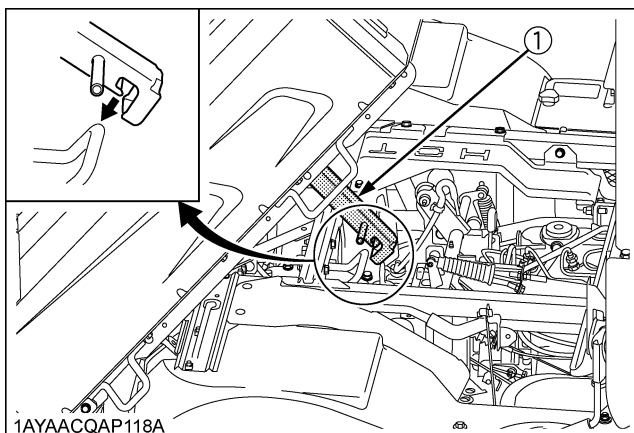

(1) Safety support

HYDRAULIC OUTLET

HYDRAULIC OUTLET

[if equipped]

Hydraulic Outlet Lever



WARNING

To avoid serious injury:

- Leaving the vehicle while the engine runs requires shifting the range gear shift lever to the "NEUTRAL" position, and locking the parking brake lever firmly.

Steps for operation

1. Remove the hydraulic hoses for hydraulic dump, and clamp the hoses so that they are not caught in rotary object.
2. Check the outlet and return directions of the hydraulic coupler and then connect the hydraulic hose.
3. Make sure that the hydraulic lever at the side of the working vehicle is in the "NEUTRAL" position.
4. Shift the hydraulic outlet lever to the "A" position or "B" position according to the implement of use.
5. Lock the hydraulic outlet lever at the "NEUTRAL" position with the restricting plate after use.

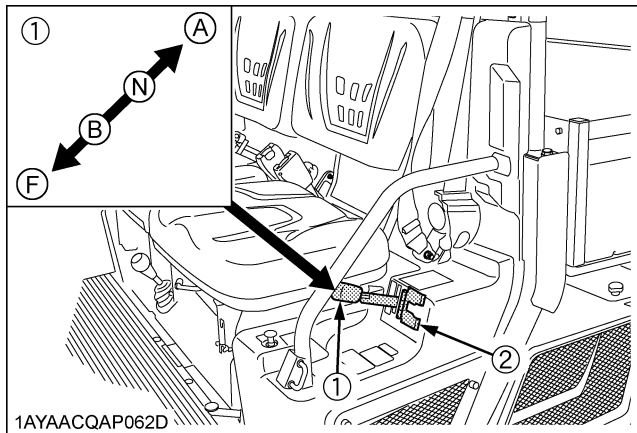

(1) Hydraulic outlet lever (if equipped) (A) "ON"
 (N) "OFF"
 (B) "ON"
 (F) "FLOAT with Detent"
 (2) Restricting plate (if equipped)

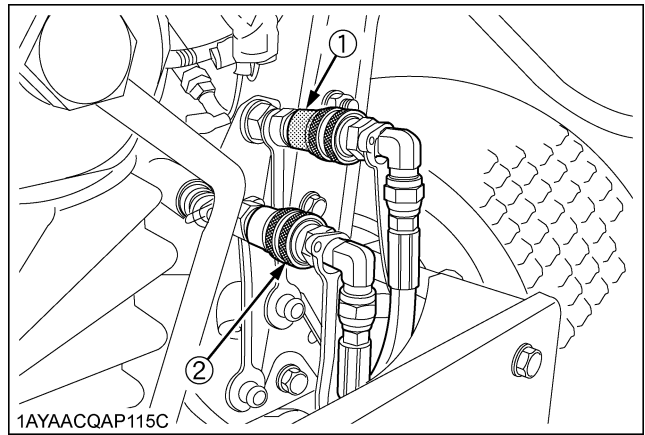

(1) Hydraulic outlet (if equipped) [yellow]
 (2) Hydraulic outlet (if equipped) [white]

Outlet →
 Return ←

Lever		Pull (A)		Push (B)	
Port	[yellow]	OUT	→	IN	←
	[white]	IN	←	OUT	→

IMPORTANT :

- Do not hold the lever in the "PULL" or "PUSH" position once the remote cylinder has reached the end of its stroke, as this will cause oil to flow through the relief valve. Forcing oil through the relief valve for extended periods will overheat the oil.
- Continuing to use the lever may cause oil temperature to rise excessively. The use of oil at a high temperature causes the seals to become damaged and fail.
- Shift the hydraulic outlet lever to the "NEUTRAL" position and then stop the engine.
- Because of the safety devices, the engine will not start except when the hydraulic outlet lever is placed in the "OFF" position and range gear shift lever is placed in the "NEUTRAL" position.
- Do not operate the hydraulic outlet lever when driving. Otherwise loss of control or failure of the power steering could occur.
- Do not use a hydraulic implement which has a hydraulic motor except those approved by Kubota.

Hydraulic Outlet Valve Coupler Connecting and Disconnecting



WARNING

To avoid serious injury:

- Stop the engine and relieve pressure before connecting or disconnecting lines.
- Do not use your hand to check for leaks.
- Make sure couplers are locked securely after connecting them.
- Always wear protective gloves when handling hydraulic tools, hoses and couplers.

Connecting

1. Remove dust plugs.
2. Clean both couplers.
3. Insert the implement coupler to the vehicle hydraulic coupler.
4. Pull the implement coupler slightly to make sure couplers are firmly connected.

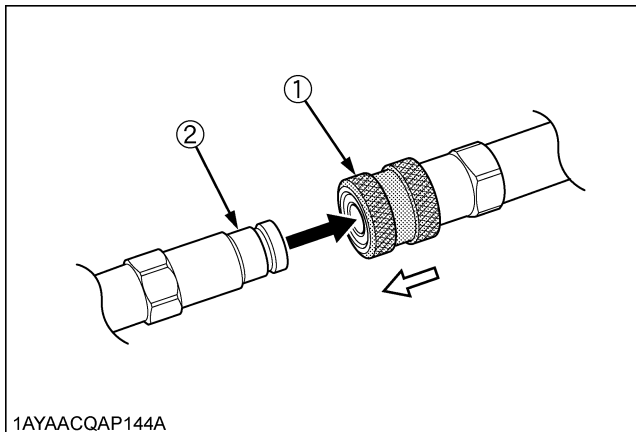

1A YA ACQAP144A
 (1) Ring of female coupler
 (2) Male coupler

Disconnecting

1. Lower the implement first to the ground to relieve hydraulic pressure in the hoses.
2. Clean the couplers.
3. Relieve pressure by moving hydraulic control levers with engine shut off.
4. Pull the hose straight from the hydraulic coupler while pulling the ring to release it.
5. Clean oil and dust from the coupler, then replace the dust plugs.

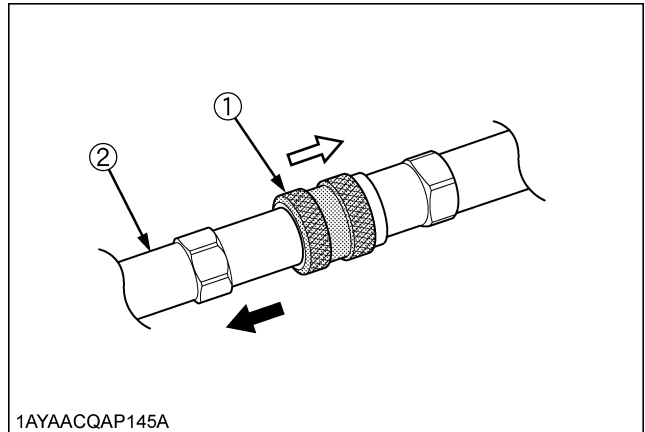

1A YA ACQAP145A
 (1) Ring of female coupler
 (2) Male coupler

NOTE :

- Your local KUBOTA Dealer can supply parts to adapt couplers to hydraulic hoses.

TIRES AND WHEELS

TIRES



WARNING

To avoid serious injury:

- Do not attempt to mount a tire on a rim. This should be done by a qualified person with the proper equipment.
- Always maintain the correct tire pressure. Do not inflate tires above the recommended pressure shown in the operator's manual.

IMPORTANT :

- Do not use tires other than those approved by KUBOTA.

■ Inflation Pressure

Though the tire pressure is factory-set to the prescribed level, it naturally drops slowly in the course of time. Thus, check it everyday and inflate as necessary.

Tire sizes	Inflation Pressure
25 x 10 - 12 HDWS, Front & Rear	140 kPa (1.4 kgf/cm ² , 20 psi)
25 x 12 - 12 Turf, Front & Rear	
25 x 10 - 12 ATV, Front & Rear	

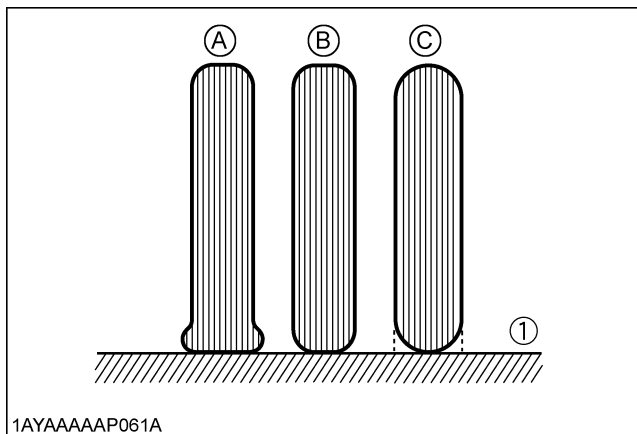

1AYAAAAAP061A

(1) Ground

- (A) "INSUFFICIENT"
- (B) "NORMAL"
- (C) "EXCESSIVE"

■ Tire Type and Use

◆ Heavy duty work site tire

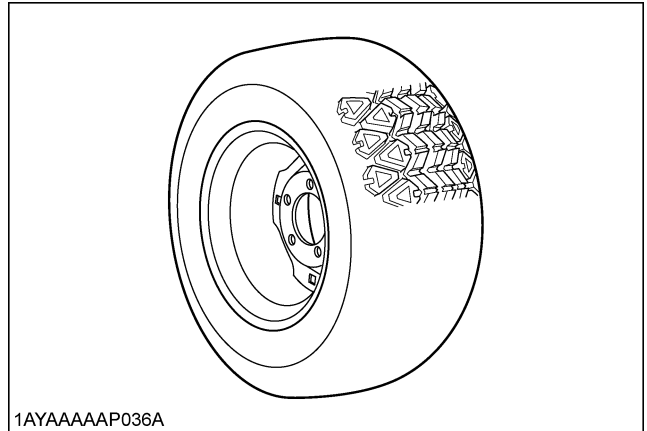

1AYAAAAAP036A

◆ Turf tire

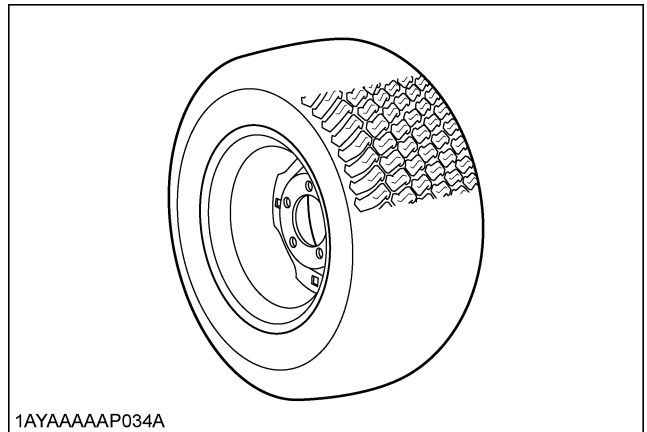

1AYAAAAAP034A

◆ All terrain vehicle tire

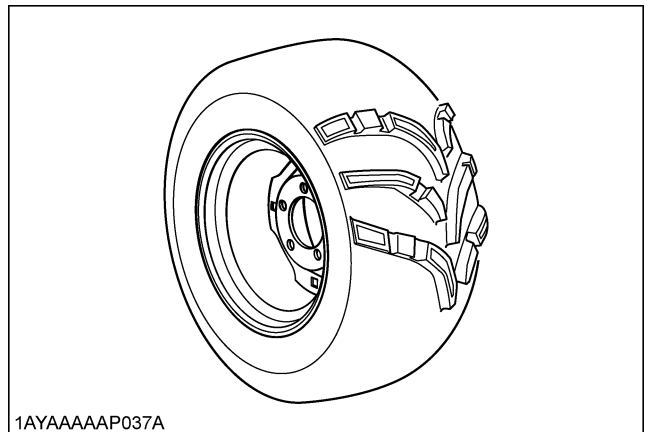

1AYAAAAAP037A

WHEELS



WARNING

To avoid serious injury:

- Support vehicle securely on stands before removing a wheel.
- Never operate vehicle with loose wheel bolts and nuts.

IMPORTANT :

- When re-fitting a wheel, tighten the bolts and nuts to the following torques then recheck after driving the vehicle 200 m (220 yards) and thereafter according to service interval.

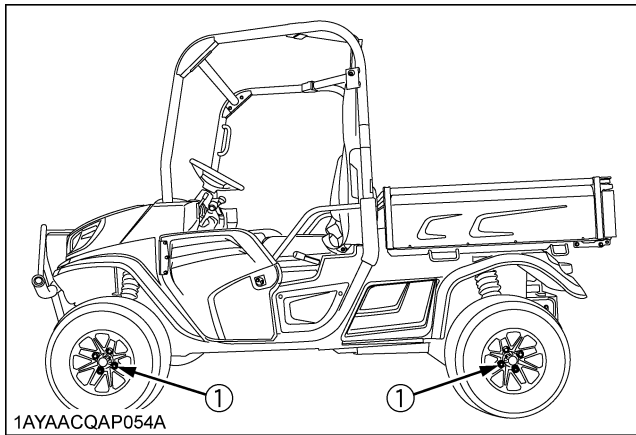

(1) Tightening torque (bolts and nuts)

- Aluminum wheel: 90 to 110 N-m
(9.2 to 11.2 kgf-m) (66.4 to 81.1 lbf-ft)
- Steel wheel: 108 to 130 N-m
(11.1 to 13.2 kgf-m) (79.7 to 95.8 lbf-ft)

SHOCK ABSORBERS

Shock Absorber Spring Adjustment



WARNING

To avoid serious injury:

- For shock absorber spring adjustment, make sure to consult your local KUBOTA dealer.

The front and rear shock absorber springs can be adjusted for different riding and loading condition.

[Shock absorber position]

Position	Spring	Load
1	Stronger	Heavy
2	↑	↑
3 (default)		
4	↓	↓
5	Weaker	Light

TOWING AND TRANSPORTING

TOWING AND TRANSPORTING

■ Rear Trailer Hitch

[if equipped]



WARNING

To avoid serious injury:

- Always tow a load slowly enough to maintain control and avoid tipping.
- To provide adequate braking ability and traction, do not tow a load unless vehicle cargo bed is loaded or attachment is installed.
- Attach a trailer to the trailer hitch only.

The rear trailer hitch load is referred to "VEHICLE LIMITATIONS" section. When towing other equipment, use a safety chain.

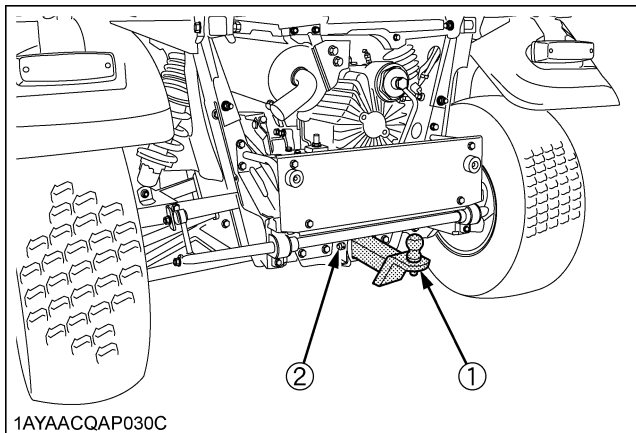

1AYAACQAP030C

- (1) Rear trailer hitch (if equipped)
 (2) Hitch pin (if equipped)

■ Front Trailer Hitch

[if equipped]



WARNING

To avoid serious injury:

- Do not tow this vehicle unless all the functions of the vehicle are properly working, since the malfunction of steering operation or braking may cause an accident.

Use the front trailer hitch for greater maneuverability in confined areas such as a barn.

The front trailer hitch load is referred to "VEHICLE LIMITATIONS" section.

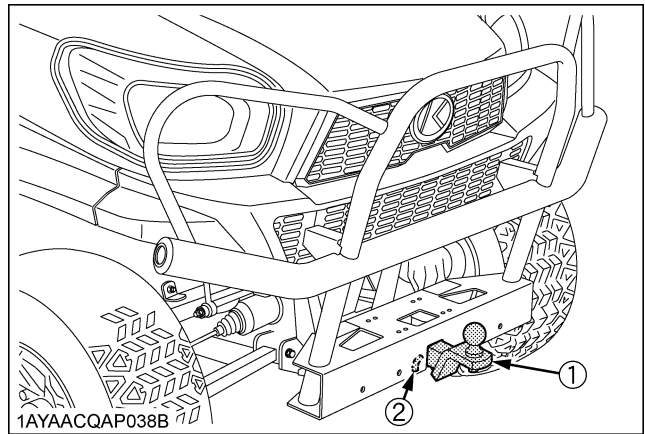

1AYAACQAP038B

- (1) Front trailer hitch (if equipped)
 (2) Hitch pin (if equipped)

■ Winch Mount Bracket

Mounting the optional winch always requires reading the instruction manual attached to the winch thoroughly before using it.

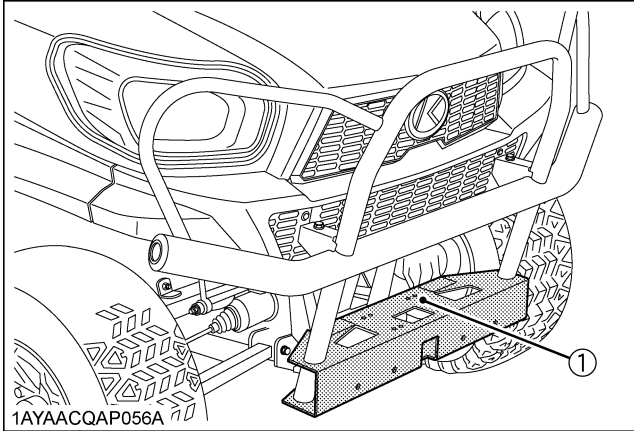

(1) Winch mount bracket

■ Transport the Vehicle Safely

Pay attention to the points below when transporting the vehicle.

1. Apply the parking brake and place chocks against the front and rear tires.
2. Secure the portions of the vehicle, which are shown in the figure below, by using adequate straps or chains.
3. When transporting vehicle on truck or trailer, always comply with Federal and/or Local regulations for securement.

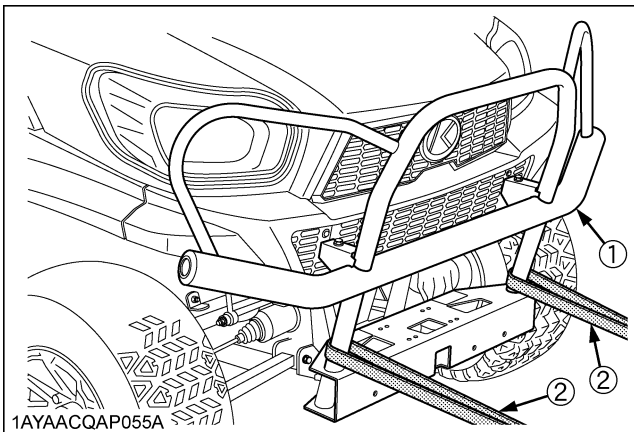

(1) Front guard
(2) Heavy-duty strap

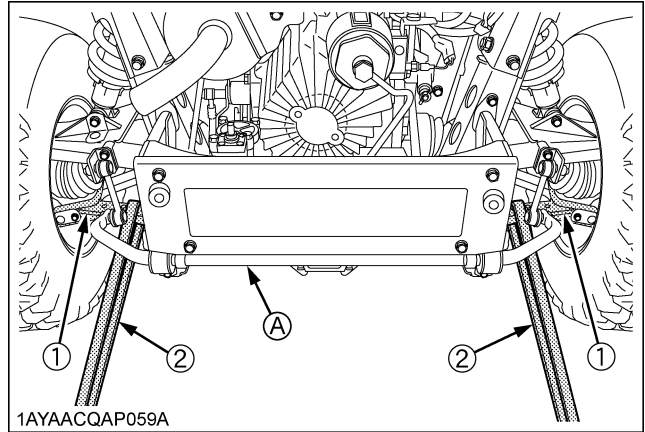

(1) Lower arm (A) Rear stabilizer
(2) Heavy-duty strap

IMPORTANT :

- Do not apply the straps and chains to the rear stabilizer.

Follow below when towing the vehicle: Otherwise, the vehicle's powertrain may get damaged.

- Set the all shift levers to "NEUTRAL" position.
- If possible, start engine and select 2WD, if creep speed is fitted ensure that it is disengaged.
- Tow the vehicle using its front hitch or drawbar.
- Never tow faster than "10 km/h (6.2 mph)".

No.	Items	Indication of Hour Meter														After 700 hrs	Ref. Page			
		50	100	150	200	250	300	350	400	450	500	550	600	650	700					
12	Fuel line	Check		○		○		○		○		○		○		○	every 100 hrs	63		
		Replace																every 2 years	82	*3
13	Air cleaner element	Clean		○		○		○		○		○		○		○	every 100 hrs	62	*1	
		Replace																every 1 year	80	*2
14	Engine oil filter	Replace	◎			○				○					○		every 200 hrs	69		
15	Transmission oil filter (VHT) (Yellow color)	Replace	◎			○				○					○		every 200 hrs	70		
16	Transmission oil filter (Suction) (Black color)	Replace	◎			○				○					○		every 200 hrs	71		
17	Brake pedal	Check	◎			○				○					○		every 200 hrs	72	*4	
18	Parking brake	Adjust	◎			○				○					○		every 200 hrs	68		
19	Brake light switch	Check	◎			○				○					○		every 200 hrs	74		
20	Front brake case	Check	◎			○				○					○		every 200 hrs	73		
21	Hydraulic tank oil	Change				○				○					○		every 200 hrs	71		
22	Radiator hose, pipe and clamp	Check				○				○					○		every 200 hrs	74		
		Replace															every 2 years	82		
23	Hydraulic oil line	Check				○				○					○		every 200 hrs	76		
		Replace															every 2 years	82	*4	
24	Intake air line	Check				○				○					○		every 200 hrs	75		
		Replace															every 2 years	82	*3	@
25	Engine breather hose	Replace															every 2 years	82	*4	
26	Brake hose & pipe	Check	◎			○				○					○		every 200 hrs	73		
		Replace															every 4 years	83	*4	
27	Tire wear	Check	◎						○						○		every 300 hrs	77		
28	Transmission fluid	Change								○							every 400 hrs	78		
29	Front axle case oil	Change								○							every 400 hrs	79		
30	Knuckle case oil	Change								○							every 400 hrs	78		

44 MAINTENANCE

No.	Items		Indication of Hour Meter													After 700 hrs	Ref. Page				
			50	100	150	200	250	300	350	400	450	500	550	600	650					700	
31	Engine valve clearance	Adjust															every 800 hrs	80	*4		
32	Fuel injection nozzle Injection pressure	Check															every 1500 hrs	80	*4	@	
33	Injection pump	Check															every 3000 hrs	80	*4	@	
34	Brake master cylinder [inner parts]	Replace															every 2 years	82	*4		
35	Brake fluid	Change															every 2 years	80	*4		
36	Rear brake cylinder seal	Replace															every 2 years	82	*4		
37	Front brake seal	Replace															every 2 years	82	*4		
38	Cooling system	Flush															every 2 years	80			
39	Coolant	Change															every 2 years	80			
40	Fuel system	Bleed															Service as required	83			
41	Fuse	Replace														83					
42	Light bulb	Replace														85					
43	Hydraulic tank	Check														85					

LUBRICANTS, FUEL AND COOLANT

No.	Locations		Capacity		Lubricants, fuel and coolant
			RTV-X900	RTV-X1120D	
1	Fuel		30 L (7.9 U.S.gals.)		No. 2-D diesel fuel No. 1-D diesel fuel if temperature is below -10 °C (14 °F)
2	Coolant (with reserve tank)		6.1 L (6.4 U.S.qts.)		Fresh clean water with anti-freeze
3	Engine crankcase	Filter exchanged	3.1 L (3.3 U.S.qts.)	4.1 L (4.3 U.S.qts.)	• Engine oil: API Service Classification CF or higher Above 25 °C (77 °F) SAE30, SAE10W-30 or 15W-40 0 to 25 °C (32 to 77 °F) SAE20, SAE10W-30 or 15W-40 Below 0 °C (32 °F) SAE10W, SAE10W-30
		Filter non-exchanged	2.7 L (2.9 U.S.qts.)	3.8 L (4.0 U.S.qts.)	
4	Transmission case		7.0 L (1.8 U.S.gals.)		For U.S.A. market: KUBOTA SUPER UDT2 fluid* For Canada market: Premium UDT fluid* For other than the above: KUBOTA UDT or SUPER UDT fluid*
5	Front axle case		0.6 L (0.6 U.S.qts.)		
6	Front knuckle case		Ref. 0.25 L (0.26 U.S.qts.)		
7	Hydraulic tank oil		18.0 L (19.0 U.S.qts.)		
8	Brake fluid (reservoir and lines)		0.4 L (0.4 U.S.qts.)		KUBOTA DOT3 GENUINE BRAKE FLUID

Greasing	No. of greasing points	Capacity	Type of grease
Parking brake lever	2	moderate amount	Multipurpose EP2 Grease (NLGI Grade No. 2)
Battery terminal	2		
Cargo lift cylinder pivot	1	Until grease overflows	
Cargo bed pivot	2	moderate amount	
VHT link	2	Until grease overflows	
	1	moderate amount	
Valve lever link	1		
4WD lever link	1		
Range gear shift link	1		
Unload link	1		
Differential lock pedal	2	Until grease overflows	
Front A-ARM	6		
Rear A-ARM	8		
Parking brake link	1	moderate amount	
Hand throttle cable [if equipped]	---		Antirust silicone grease

NOTE :

* The product name of KUBOTA genuine UDT fluid may be different from that in the Operator's Manual depending on countries or territories. Consult your local KUBOTA Dealer for further detail.

For North American market

NOTE :◆ **Engine Oil:**

- Oil used in the engine should have an American Petroleum Institute (API) service classification and Proper SAE Engine Oil according to the ambient temperatures as shown above:
- Refer to the following table for the suitable API classification engine oil according to the engine type (with internal EGR, external EGR or non-EGR) and the fuel.

Fuel used	Engine oil classification (API classification)	
	Oil class of engines except external EGR	Oil class of engines with external EGR
Ultra Low Sulfur Fuel [<0.0015% (15 ppm)]	CF, CF-4, CG-4, CH-4 or CI-4	CF or CI-4 (Class CF-4, CG-4 and CH-4 engine oils cannot be used on EGR type engines)

EGR: Exhaust Gas Re-circulation

- The CJ-4 engine oil is intended for DPF (Diesel Particulate Filter) type engines, and cannot be used on this vehicle.

	except external EGR	with external EGR
Models	RTV-X900, RTV-X1120D	---

◆ **Fuel:**

- Cetane number of 45 is minimum. Cetane number greater than 50 is preferred, especially for temperatures below -20 °C (-4 °F) or elevations above 1500 m (5000 ft).
- Diesel fuels specified to EN 590 or ASTM D975 are recommended.
- No.2-D is a distillate fuel of lower volatility for engines in industrial and heavy mobile service. (SAE J313 JUN87)

◆ **Transmission Oil:**

To complete lubrication of the transmission, it is important that a multi-grade transmission fluid is used in this system. We recommend the use of **KUBOTA genuine fluid** for optimum protection and performance.

(See the first table of "LUBRICANTS, FUEL AND COOLANT" in "MAINTENANCE" section. Consult your local KUBOTA Dealer for further detail.)

Do not mix different brands together.

◆ **Hydraulic tank oil:**

To insure proper operation of the hydraulic and VHT system, it is important that a multi-grade transmission fluid is used in this system. We recommend the use of **KUBOTA genuine fluid** for optimum protection and performance.

(See the first table of "LUBRICANTS, FUEL AND COOLANT" in "MAINTENANCE" section. Consult your local KUBOTA Dealer for further detail.)

Do not mix different brands together.

◆ **Brake fluid:**

Always use KUBOTA **DOT3 GENUINE BRAKE FLUID** from a sealed container. If it is not available, you should use only DOT3 fluid as a temporary replacement from a sealed container.

However, the use of any non-KUBOTA brake fluid can cause corrosion and decrease the life of the system.

Have the brake system flushed and refilled with KUBOTA **DOT3 GENUINE BRAKE FLUID** as soon as possible.

- Indicated capacities of water and oil are manufacturer's estimate.

For other than North American market

NOTE :

◆ **Engine Oil:**

- Oil used in the engine should have an American Petroleum Institute (API) service classification and Proper SAE Engine Oil according to the ambient temperatures as shown above:
- With the emission control now in effect, the CF-4 and CG-4 lubricating oils have been developed for use of a low-sulfur fuel on on-road vehicle engines. When an off-road vehicle engine runs on a high-sulfur fuel, it is advisable to employ the "CF or better" lubricating oil with a high Total Base Number (TBN of 10 minimum).
- Refer to the following table for the suitable API classification engine oil according to the engine type (with internal EGR, external EGR or non-EGR) and the fuel (low-sulfur or high-sulfur fuel).

Fuel used	Engine oil classification (API classification)	
	Oil class of engines except external EGR	Oil class of engines with external EGR
High Sulfur Fuel [≥ 0.05% (500 ppm)]	CF (If the "CF-4, CG-4, CH-4 or CI-4" lubricating oil is used with a high-sulfur fuel, change the lubricating oil at shorter intervals. (approximately half))	---
Low Sulfur Fuel [<0.05% (500 ppm)] or Ultra Low Sulfur Fuel [<0.0015% (15 ppm)]	CF, CF-4, CG-4, CH-4 or CI-4	CF or CI-4 (Class CF-4, CG-4 and CH-4 engine oils cannot be used on EGR type engines)

EGR: Exhaust Gas Re-circulation

- The CJ-4 engine oil is intended for DPF (Diesel Particulate Filter) type engines, and cannot be used on this vehicle.

	except external EGR	with external EGR
Models	RTV-X900, RTV-X1120D	---

◆ **Fuel:**

- Cetane number of 45 minimum. Cetane number greater than 50 is preferred, especially for temperatures below -20°C or elevations above 1500 m.
- If diesel fuel with sulfur content greater than 0.5% (5000 ppm) sulfur content is used, reduce the service interval for engine oil and filter by 50%.
- NEVER use diesel fuel with sulfur content greater than 0.05% (500 ppm) for EXTERNAL EGR type engine.
- DO NOT use diesel fuel with sulfur content greater than 1.0% (10000 ppm).
- Diesel fuels specified to EN 590 or ASTM D975 are recommended.
- No.2-D is a distillate fuel of lower volatility for engines in industrial and heavy mobile service. (SAE J313 JUN87)

◆ **Transmission Oil:**

To complete lubrication of the transmission, it is important that a multi-grade transmission fluid is used in this system. We recommend the use of **KUBOTA genuine fluid** for optimum protection and performance.

(See the first table of "LUBRICANTS, FUEL AND COOLANT" in "MAINTENANCE" section. Consult your local KUBOTA Dealer for further detail.)

Do not mix different brands together.

◆ **Hydraulic tank oil:**

To insure proper operation of the hydraulic and VHT system, it is important that a multi-grade transmission fluid is used in this system. We recommend the use of **KUBOTA genuine fluid** for optimum protection and performance.

(See the first table of "LUBRICANTS, FUEL AND COOLANT" in "MAINTENANCE" section. Consult your local KUBOTA Dealer for further detail.)

Do not mix different brands together.

◆ **Brake fluid:**

Always use KUBOTA **DOT3** GENUINE BRAKE FLUID from a sealed container. If it is not available, you should use only DOT3 fluid as a temporary replacement from a sealed container.

However, the use of any non-KUBOTA brake fluid can cause corrosion and decrease the life of the system.

Have the brake system flushed and refilled with KUBOTA **DOT3** GENUINE BRAKE FLUID as soon as possible.

- Indicated capacities of water and oil are manufacturer's estimate.

PERIODIC SERVICE



WARNING

To avoid serious injury:

- Do not work under any hydraulically supported devices. They can settle, suddenly leak down, or be accidentally lowered. If necessary to work under vehicle or any vehicle elements for servicing or adjustment, securely support them with stands or suitable blocking beforehand.

HOW TO OPEN THE HOOD AND TILT THE SEAT



WARNING

To avoid serious injury from contact with moving parts;

- Never open the cover under the seat while the engine is running unless servicing requires such access.

■ Hood

To open the hood, pull the latch lever toward left side of machine to release the latch and open the hood.

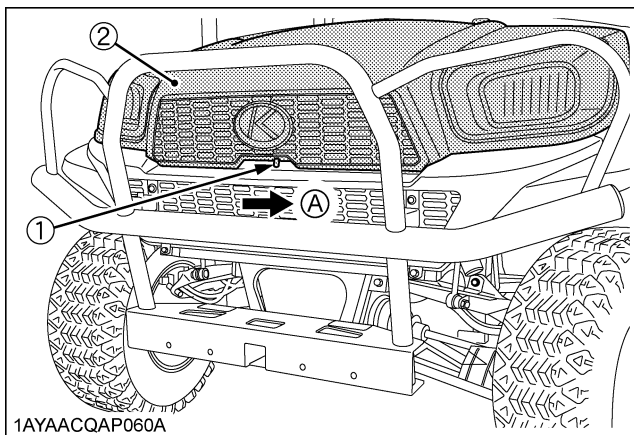

1AYAACQAP060A

- (1) Latch lever
- (2) Hood

(A) "RELEASE"

NOTE :

- To close the hood, press-fit the hood into position with both hands.

■ Seat

To open the seats, raise the seats to the forward position. Then remove the utility box and maintenance cover.

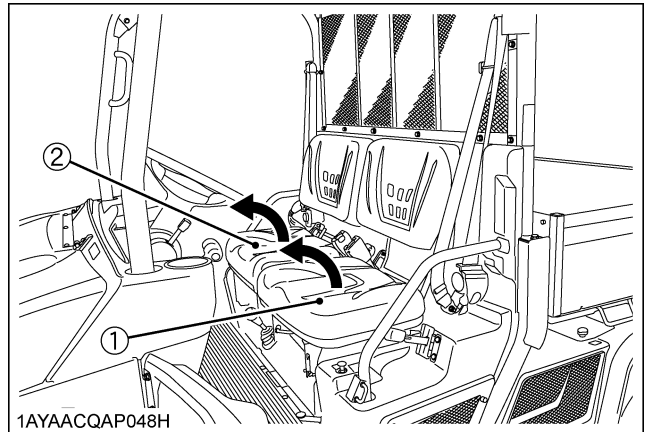

1AYAACQAP048H

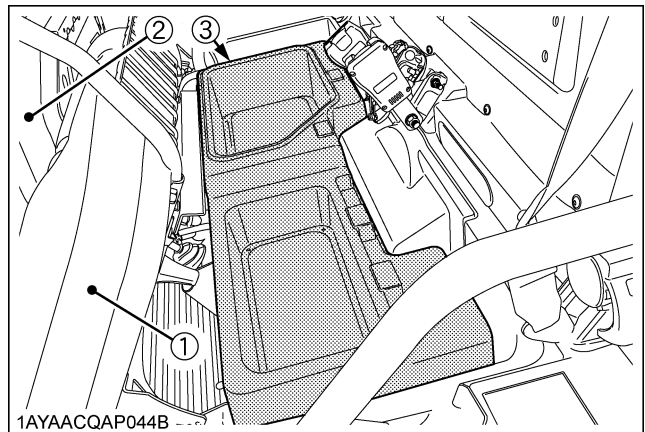

1AYAACQAP044B

- (1) Operator's seat
- (2) Passenger seat
- (3) Utility box

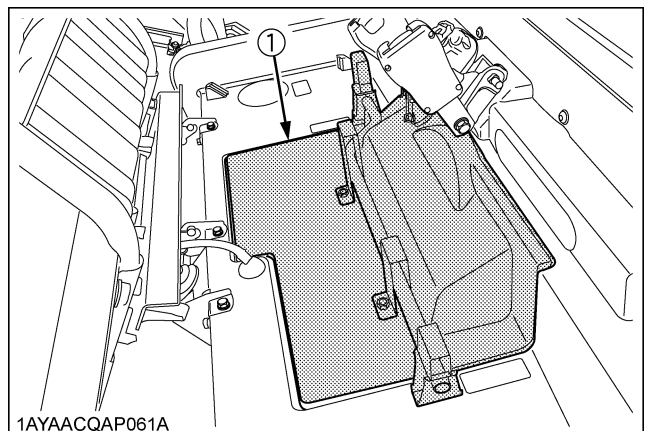

1AYAACQAP061A

- (1) Maintenance cover

HOW TO RAISE THE CARGO BED



WARNING

To avoid serious injury:

- When servicing under raised bed, make sure safety support is properly mounted.
- Do not touch muffler or exhaust pipes while they are hot; Severe burns could result.

■ Raising and Lowering the Cargo Bed [if equipped with hydraulic dump]

See "Raising and Lowering the Cargo Bed [if equipped with hydraulic dump]" in "CARGO BED" section.

■ Raising and Lowering the Cargo Bed [without hydraulic dump]

See "Raising and Lowering the Cargo Bed [without hydraulic dump]" in "CARGO BED" section.

JACK-UP POINT



WARNING

To avoid serious injury, death or vehicle damage:

- Do not work under the vehicle unless it is secured by safe stands or suitable blocking.

■ Front End

Jack up at the plate under the front axle case only.

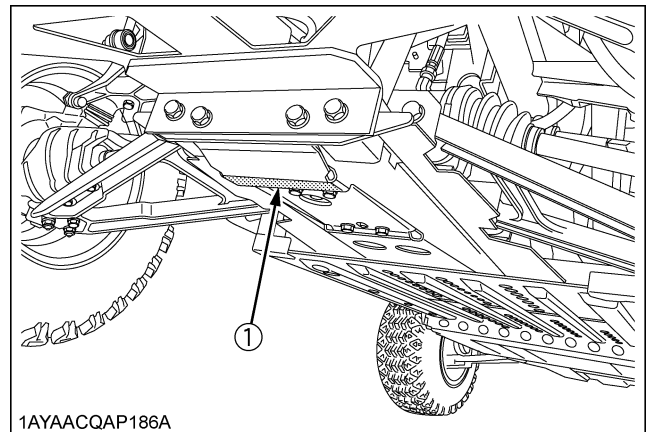
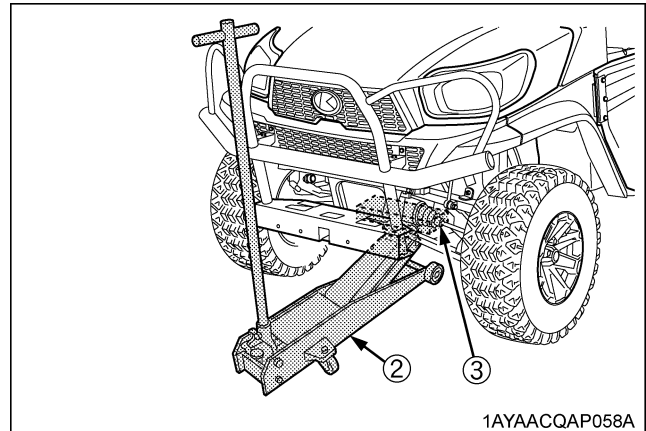

- (1) Plate under the front axle case
 (2) Jack
 (3) Wooden block

■Rear End

Jack up the rear end after placing a wooden block under the bottom plate of the transmission frame.

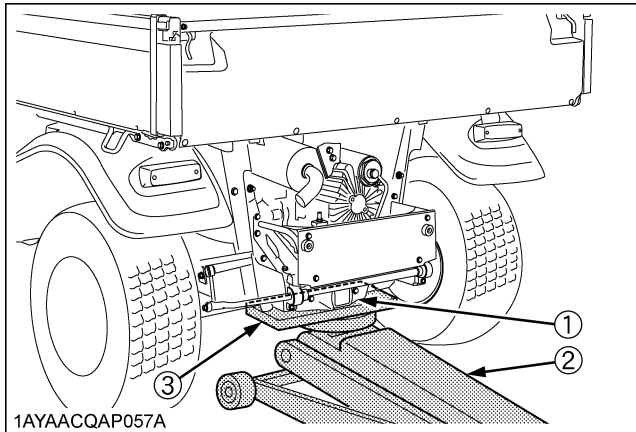

- (1) Bottom plate of the transmission frame
- (2) Jack
- (3) Wooden block

IMPORTANT :

- To avoid damage to frame, do not pick up on the rear upper cross member when hoisting the vehicle.

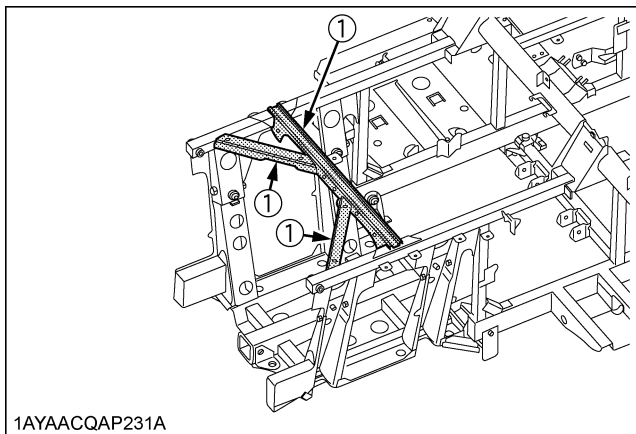

- (1) Rear upper cross member

DAILY CHECK

For your own safety and maximum service life of the vehicle, make a thorough daily inspection before operating the vehicle to start the engine.



WARNING

To avoid serious injury:

- Be sure to check and service the vehicle on a flat surface with the engine shut off and the parking brake "ON".

■Walk Around Inspection

Look around and under the vehicle for such items as loose bolts, trash build-up, oil or coolant leaks, broken or worn parts.

■Checking around Engine

1. Park the vehicle on a level surface.
2. Stop the engine.
3. Raise the cargo bed.
4. Mount the safety support.
5. Check around the engine for mud or foreign materials.
6. Remove all foreign materials if they are found.

■ Checking and Refueling

! WARNING

To avoid serious injury:

- Do not smoke while refueling.
- Be sure to stop the engine before refueling.

1. Turn the key switch to "ON", check the amount of fuel by fuel gauge.
2. Fill fuel tank when fuel gauge shows 1/4 or less fuel in tank.
3. Use grade No.2-Diesel fuel at temperatures above -10 °C (14 °F).
Use grade No.1-Diesel fuel at temperatures below -10 °C (14 °F).

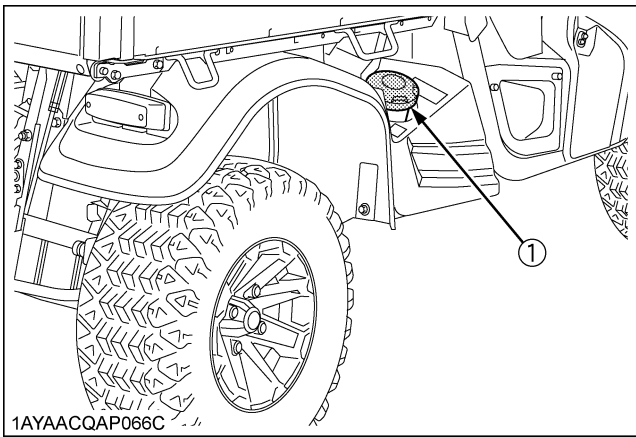

(1) Fuel tank cap

Fuel tank capacity	30 L (7.9 U.S.gals.)
--------------------	----------------------

IMPORTANT :

- Do not permit dirt or trash to get into the fuel system.
- Be careful not to let the fuel tank become empty, otherwise air will enter the fuel system, necessitating bleeding before next engine start.
- Be careful not to spill during refueling. If should spill, wipe it off at once, or it may cause a fire.
- To prevent water condensation from accumulating in the fuel tank, fill the tank before parking overnight.

■ Checking Engine Oil Level

! WARNING

To avoid serious injury:

- Be sure to stop the engine before checking the oil level.

1. Park the vehicle on a level surface.
2. Raise the cargo bed and mount the safety support.
3. Stop the engine.
4. Check engine oil before starting the engine or 5 minutes or more after the engine has stopped.
5. To check the oil level, draw out the dipstick, wipe it clean, replace it, and draw it out again. Check to see that the oil level lies between the 2 debossed lines. If the level is too low, add new prescribed oil to the prescribed level at the oil inlet.
(See the first table of "LUBRICANTS, FUEL AND COOLANT" in "MAINTENANCE" section.)

[RTV-X900]

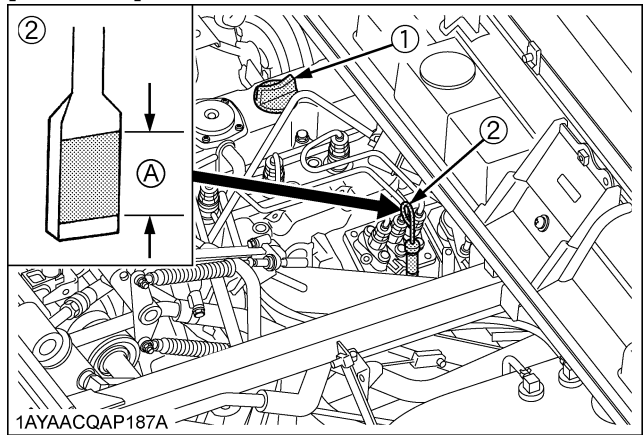

(1) Oil inlet (A) Oil level is acceptable within this range.
(2) Dipstick

[RTV-X1120D]

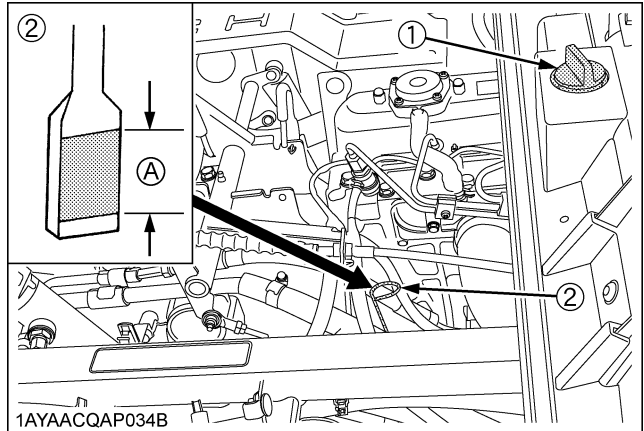

(1) Oil inlet (A) Oil level is acceptable within this range.
(2) Dipstick

IMPORTANT :

- When using an oil of different maker or viscosity from the previous one, remove all of the old oil. Never mix 2 different types of oil.
- If oil level is low, do not run engine.

■Checking Transmission Fluid Level

1. Park the vehicle on a level surface.
2. Raise the cargo bed and mount the safety support.
3. Stop the engine.
4. To check the oil level, draw out the dipstick, wipe it clean, replace it, and draw it out again. Check to see that the oil level lies within the cross hatched area. If the level is too low, add new prescribed oil to the prescribed level at the oil inlet.
(See the first table of "LUBRICANTS, FUEL AND COOLANT" in "MAINTENANCE" section.)

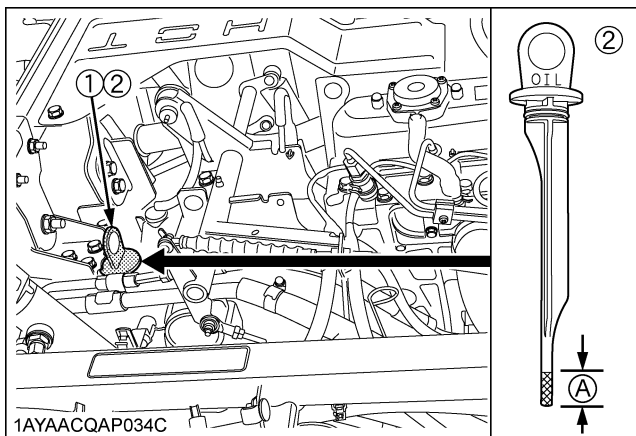

(1) Oil inlet (A) Oil level is acceptable within this range.
(2) Dipstick

■Checking Hydraulic Oil Tank Level

1. Park the vehicle on a level surface.
2. Stop the engine.
3. Open the seat and remove the utility box.
4. Remove the rubber cap.
5. To check the oil level, remove the dipstick, wipe it clean, screw it into filling hole and remove dipstick again.
If the level is too low, add new prescribed oil to the prescribed level at the oil inlet.
(See the first table of "LUBRICANTS, FUEL AND COOLANT" in "MAINTENANCE" section.)

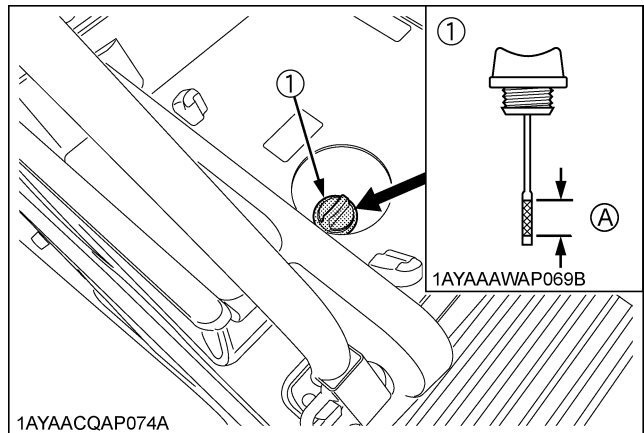

(1) Filling plug with dipstick (A) Oil level is acceptable within this range

IMPORTANT :

- If oil level is low, do not run engine.

IMPORTANT :

- If oil level is low, do not run engine.

■ Checking Coolant Level



WARNING

To avoid serious injury:

- Do not remove radiator cap while coolant is hot. When cool, slowly rotate cap to the first stop and allow sufficient time for excess pressure to escape before removing the cap completely.

1. Park the vehicle on a level surface.
2. Stop the engine.
3. Open the hood.
4. Check to see that the coolant level is between the "FULL" and "LOW" marks of recovery tank.
5. When the coolant level drops due to evaporation, add water only up to the full level.
In case of leakage, add anti-freeze and water in the specified mixing ratio up to the full level.
(See "Flush Cooling System and Changing Coolant" in "EVERY 2 YEARS" in "PERIODIC SERVICE" section.)

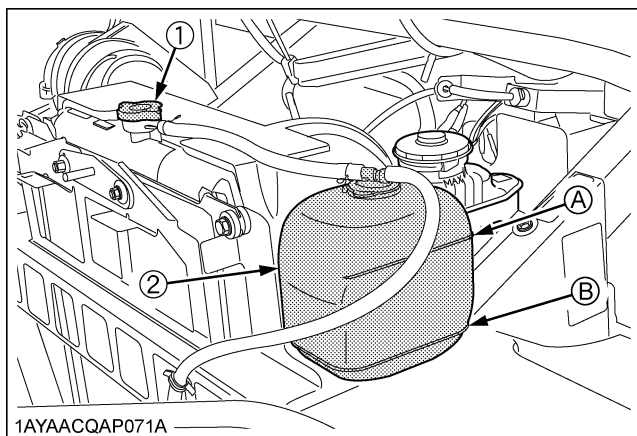

1AYAACQAP071A

- | | |
|-------------------|------------|
| (1) Radiator cap | (A) "FULL" |
| (2) Recovery tank | (B) "LOW" |

IMPORTANT :

- If the radiator cap has to be removed, follow the caution above and securely retighten the cap.
- Use clean, fresh water and anti-freeze to fill the recovery tank.
- If water should leak, consult your local KUBOTA Dealer.

■ Cleaning Radiator Screen



WARNING

To avoid serious injury:

- Be sure to stop the engine before removing the screen.

1. Park the vehicle on a flat surface.
2. Stop the engine.
3. Open the hood.
4. Detach the screen and remove all foreign materials.

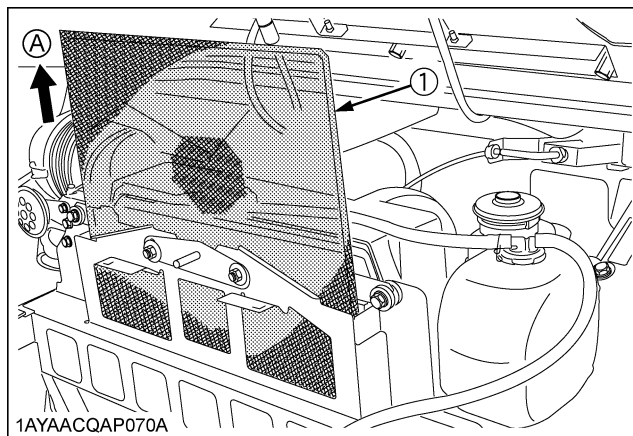

1AYAACQAP070A

- | | |
|---------------------|--------------|
| (1) Radiator screen | (A) "DETACH" |
|---------------------|--------------|

IMPORTANT :

- Radiator screen must be clean from debris to prevent engine from overheating.

■Cleaning Oil Cooler Net

WARNING

To avoid serious injury:

- Allow oil cooler or oil line parts to cool down sufficiently, they can be hot and can cause injury.

1. Park the vehicle on a flat surface.
2. Stop the engine.
3. Open the seats and remove the utility box and maintenance cover.
4. Detach the oil cooler net and remove all trash.

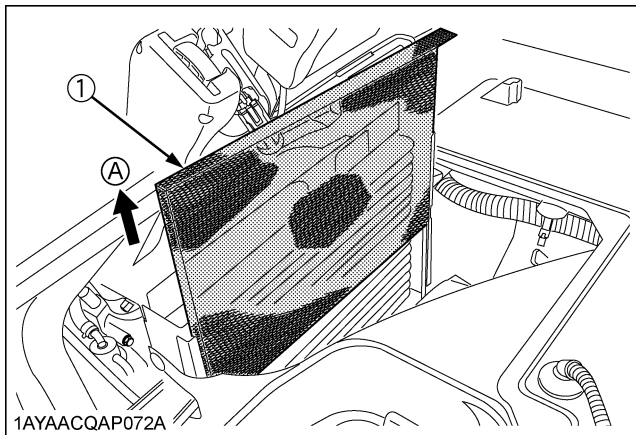

(1) Oil cooler net

(A) "DETACH"

■Checking Brake Fluid Level

WARNING

To avoid serious injury:

- Never operate the vehicle, if the brake fluid is below the "MIN" mark.
- Use only KUBOTA DOT3 GENUINE BRAKE FLUID from a sealed container. Using other type of oil ruins synthetic resin or rubber installed in brake system components, and may cause brake failure.
- Avoid contamination of the brake fluid. Thoroughly clean area around the filler cap before removing. Do not open the brake fluid reservoir cap unless absolutely necessary.
- Use extreme care when filling the reservoir. If brake fluid is spilled on the power steering hose, wash off with water immediately. Brake fluid quickly ruins synthetic resin or rubber hoses.

1. Park the vehicle on a level surface.
2. Open the hood.
3. Check to see that the brake fluid level is between the "MAX" and "MIN" marks.
4. If it is below the "MIN" mark, add brake fluid to the "MAX" mark.

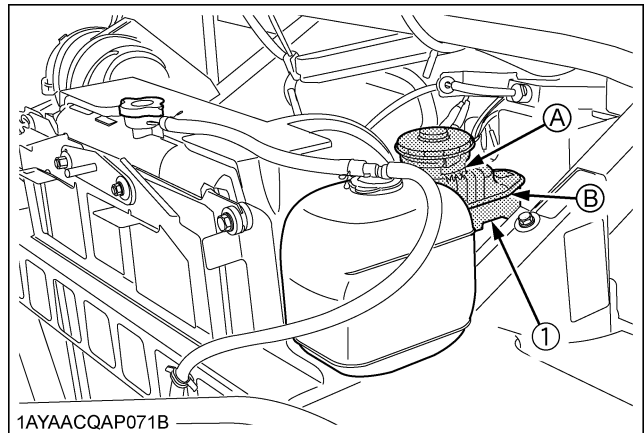

(1) Oil tank

(A) "MAX"

(B) "MIN"

■ Checking Brake Pedal



WARNING

To avoid serious injury:

- Stop the engine and chock the wheels before checking brake pedal.

1. Inspect the brake pedals for free travel, and smooth operation.
2. Adjust if incorrect measurement is found: (See "Checking Brake Pedal" in "EVERY 200 HOURS" in "PERIODIC SERVICE" section.)

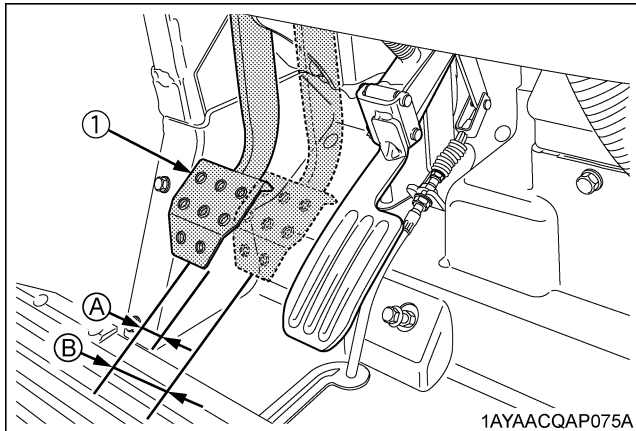

(1) Brake pedal

(A) "FREE TRAVEL"
(B) "PEDAL STROKE"

■ Checking Parking Brake

Pull the parking brake lever to apply the brakes. With the key switch at "ON" position, the parking brake indicator on the instrument panel lights up. To release the brakes, push in the button at the side of the parking brake lever and tilt the lever forward.

NOTE :

- Make sure the parking brake warning lamp (Ⓢ) on the Easy Checker(TM) goes off when parking brake lever is forward.

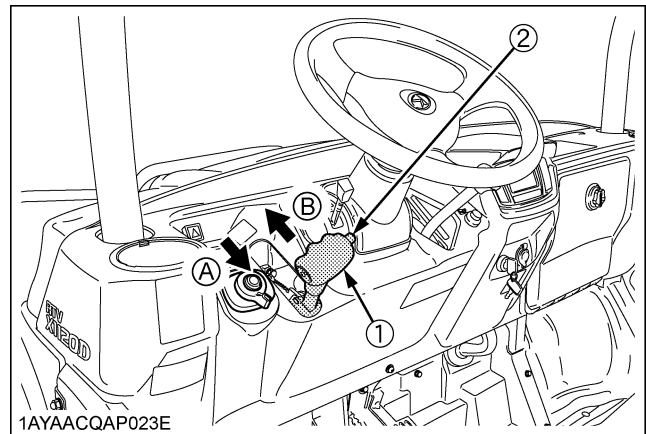

(1) Parking brake lever
(2) Release button

(A) "PULL"
(B) "RELEASE"

■ Checking Easy Checker(TM)

1. Inspect the instrument panel for broken Easy Checker(TM) lamps.
2. Consult your local KUBOTA Dealer if broken.

■ Checking Head Light, Turn Signal Light (if equipped) etc.

1. Inspect the lights for broken bulbs and lenses.
2. Replace if broken.

■ Checking Seat Belt and ROPS

1. Always check condition of the seat belts before operating the vehicle.
2. Replace if damaged.

■ Checking Joint Boot

1. Check to see if the joint boots are not damaged.
2. If the boots are cuts, cracked or shows signs of deterioration, consult your local KUBOTA Dealer.

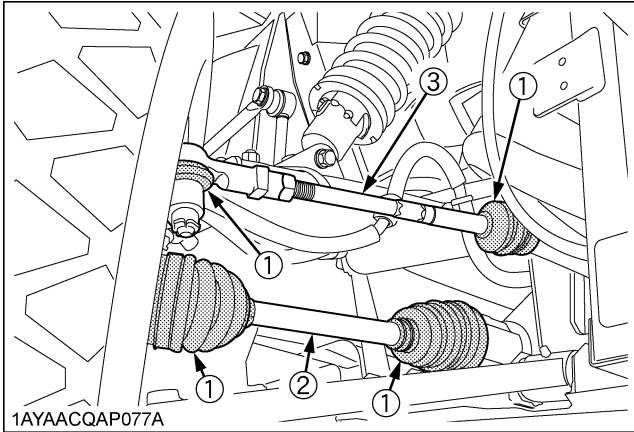

- (1) Joint boot
- (2) Front drive shaft
- (3) Tie rod

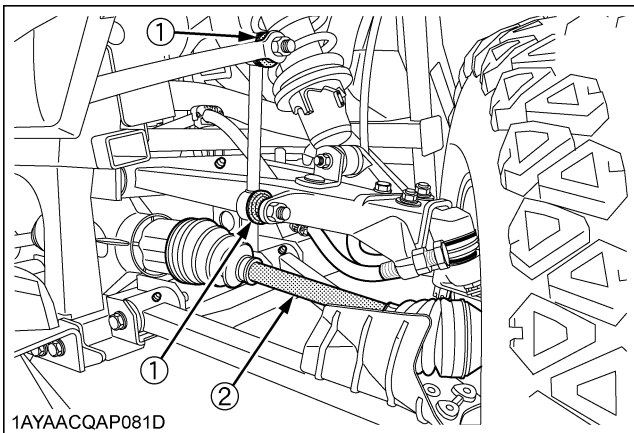

- (1) Joint boot
- (2) Front drive shaft

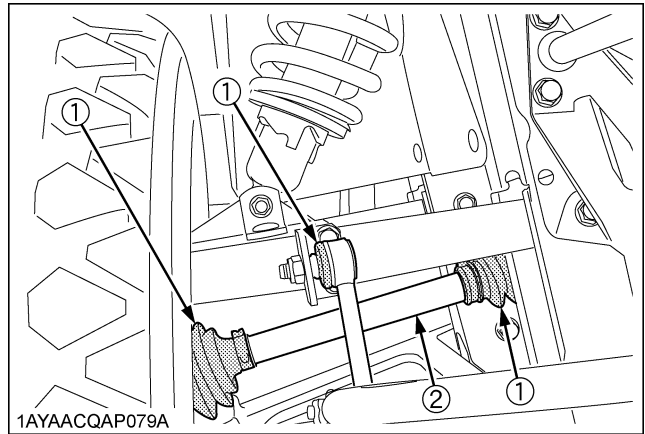

- (1) Joint boot
- (2) Rear drive shaft

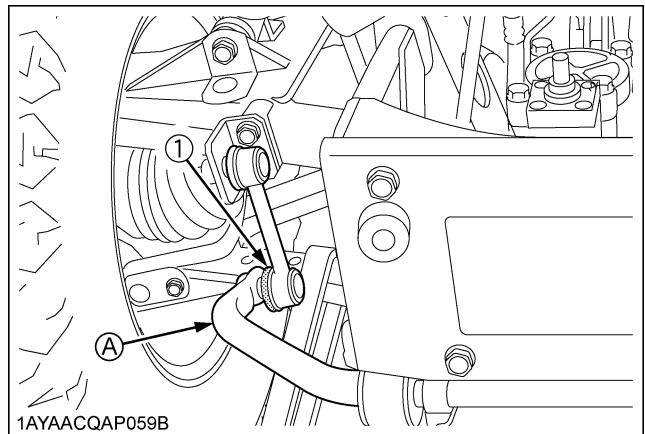

- (1) Joint boot
- (A) Rear stabilizer

[Front]

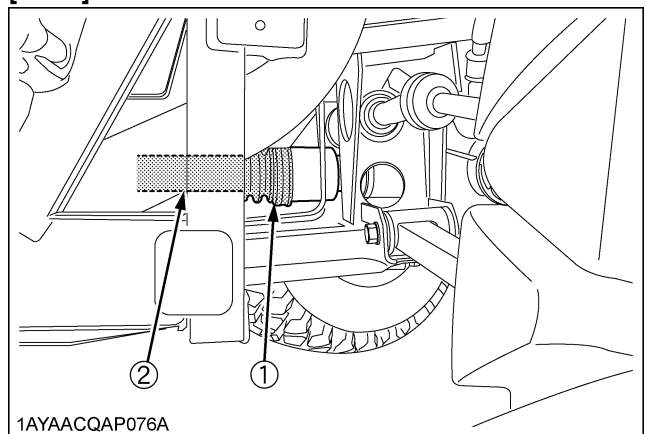

- (1) Joint boot
- (2) Drive shaft

[Rear]

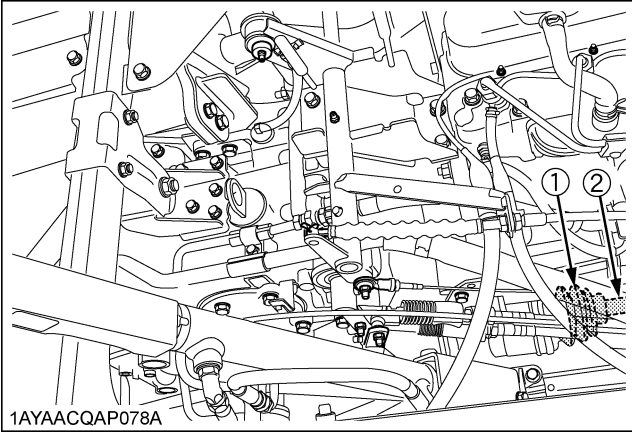

(1) Joint boot
(2) Drive shaft

■ Checking Tire Inflation Pressure

Though the tire pressure is factory-set to the prescribed level, it naturally drops slowly in the course of time. Thus, check it everyday and inflate as necessary.

Tire sizes	Inflation Pressure
25 x 10 - 12 HDWS, Front & Rear	140 kPa (1.4 kgf/cm ² , 20 psi)
25 x 12 - 12 Turf, Front & Rear	
25 x 10 - 12 ATV, Front & Rear	

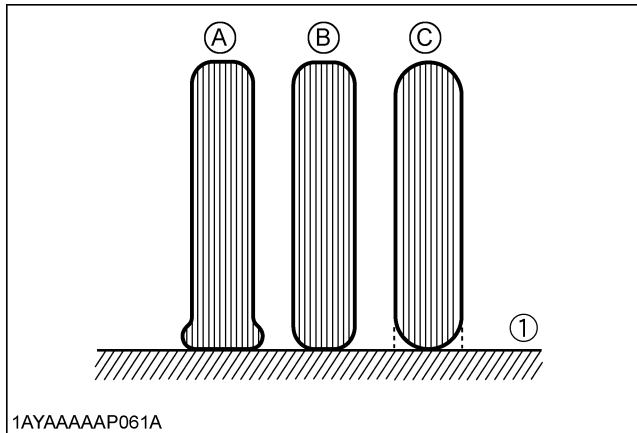

(1) Ground

(A) "INSUFFICIENT"
(B) "NORMAL"
(C) "EXCESSIVE"

■ Checking Backup Beeper

[if equipped]

1. Sit on the operator's seat.
2. Set the parking brake and stop the engine.
3. Shift the range gear shift lever to the "NEUTRAL" position.
4. Turn the key to "ON" position.
5. Shift the range gear shift lever to the "REVERSE" position.
6. If the backup beeper does not beep, consult your local KUBOTA Dealer.

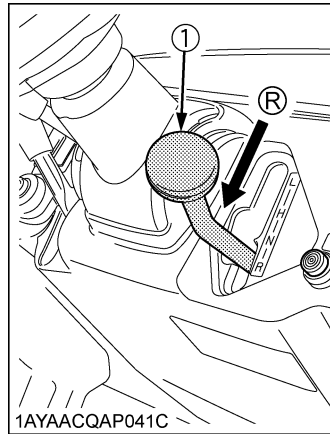

(1) Range gear shift lever
(2) Backup beeper (if equipped)

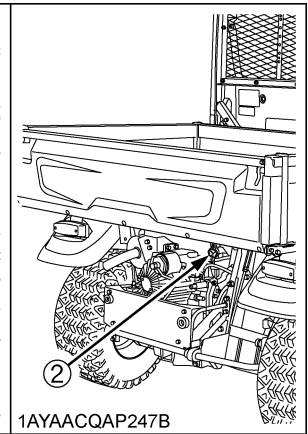

(R) "REVERSE"

EVERY 50 HOURS

■ Greasing

Apply a small amount of multi-purpose grease to the following points every 50 hours: If you operated the vehicle in extremely wet and muddy conditions, lubricate grease fittings more often.

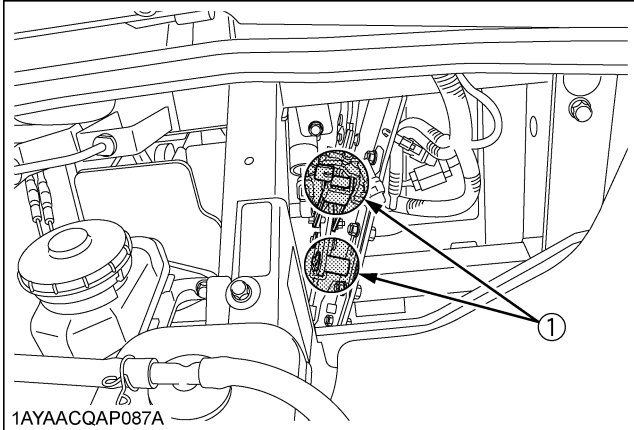

(1) Parking brake lever (spray type grease)

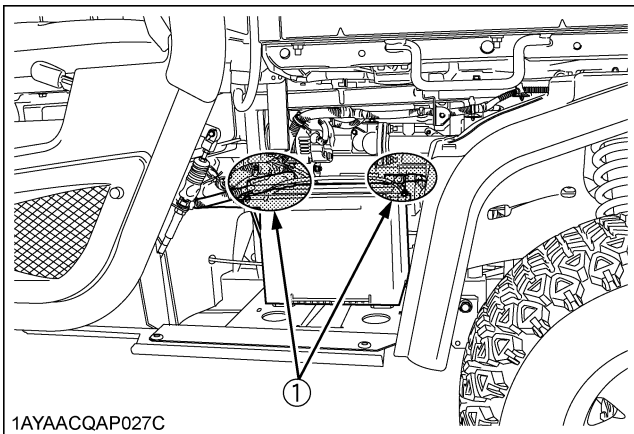

(1) Battery terminals

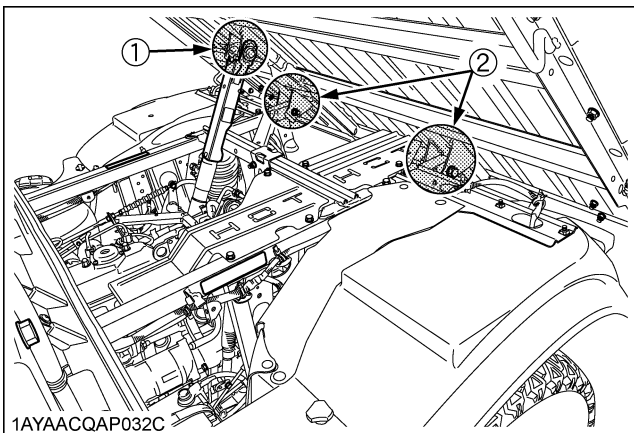

(1) Cargo lift cylinder pivot (Grease fitting)
(2) Cargo bed pivot (spray type grease)

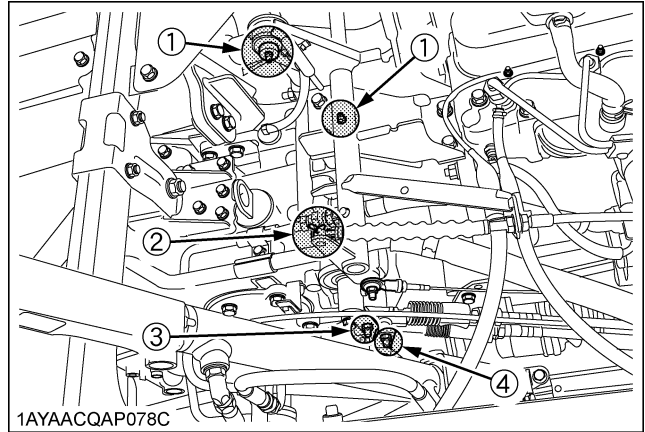

(1) VHT link (Grease fitting)
(2) VHT link (spray type grease)
(3) Valve lever link (spray type grease)
(4) 4WD lever link (spray type grease)

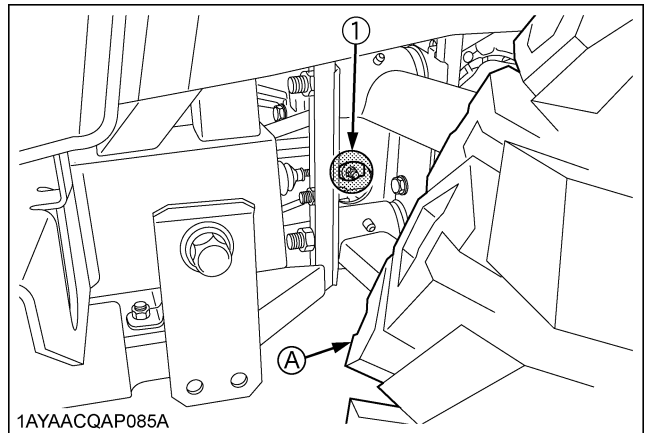

(1) Range gear shift link (spray type grease) (A) Left rear tire

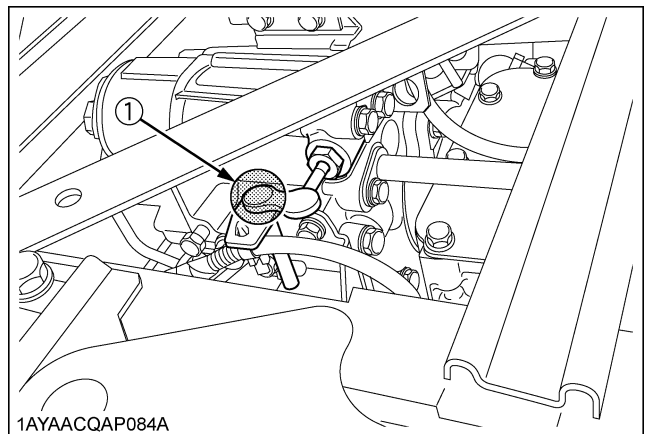

(1) Unload link (spray type grease)

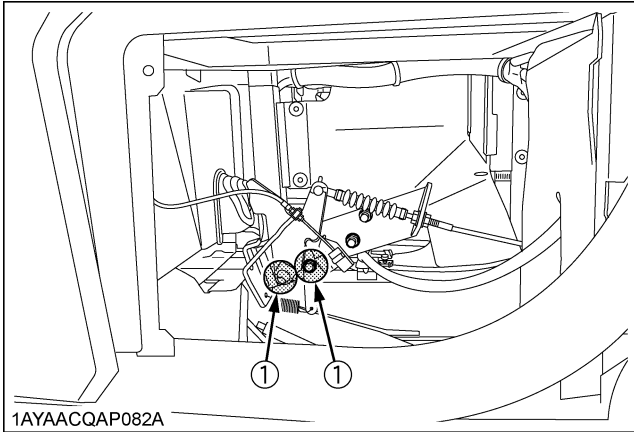

1AYAACQAP082A

(1) Differential lock pedal (spray type grease)

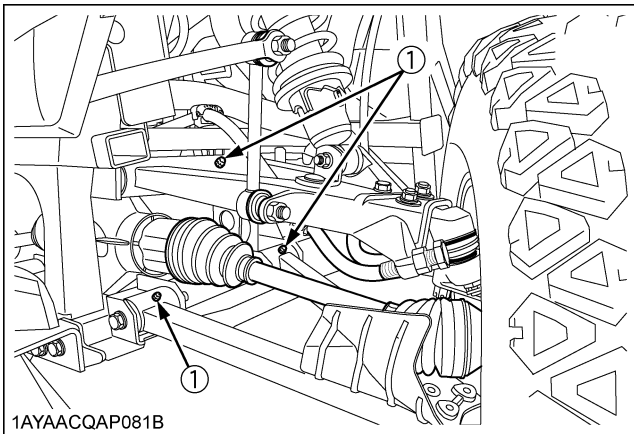

1AYAACQAP081B

(1) Front A-ARM (Grease fitting)

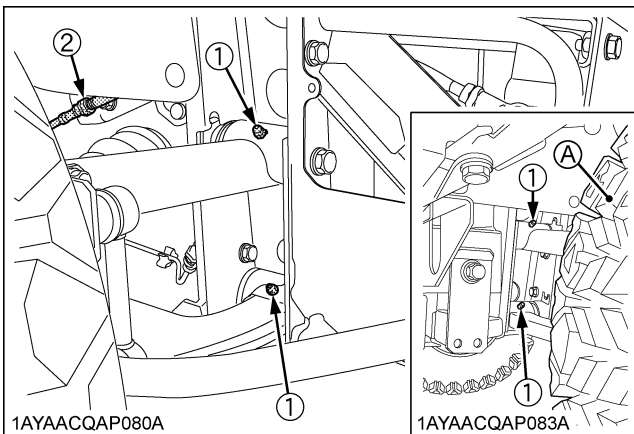

1AYAACQAP080A

(1) Rear A-ARM (Grease fitting)
(2) Parking brake link (spray type grease)

1AYAACQAP083A

(A) Left rear tire

■ Checking Engine Start System

⚠ WARNING

To avoid serious injury:

- Do not allow anyone near the vehicle while testing.
- If the vehicle does not pass the test do not operate the vehicle.

◆ Preparation before testing.

1. Place all control levers in the "NEUTRAL" position.
2. Set the parking brake and stop the engine.

◆ Test: Range gear shift lever safety switch

1. Sit on the operator's seat.
2. Shift the range gear shift lever to H position.
3. Return the Speed control pedal to the "NEUTRAL" position.
4. Shift the hydraulic lift cylinder lever to the "NEUTRAL" position.
5. Turn the key to "START" position.
6. The engine must not crank.
7. Repeat the step 2 to 6 with the range gear shift lever at "L" and "R" each position.
8. If it cranks, consult your local KUBOTA Dealer for service.

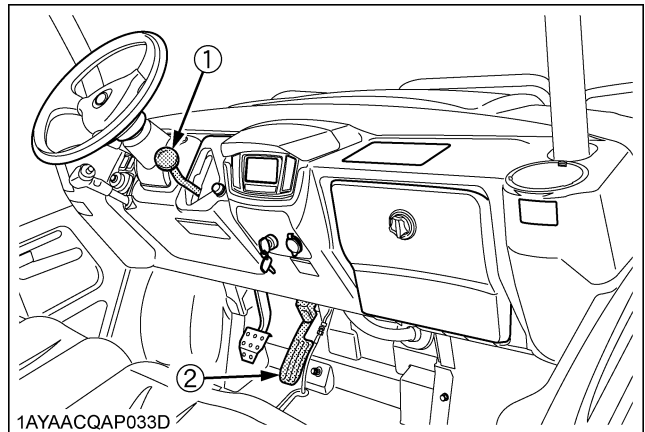

1AYAACQAP033D

(1) Range gear shift lever
(2) Speed control pedal

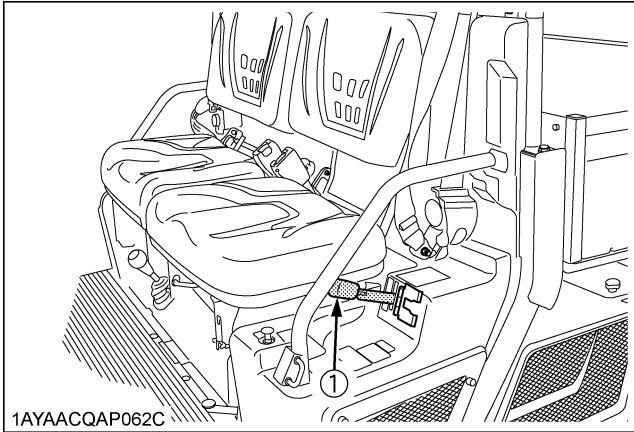

1AYAACQAP062C

(1) Hydraulic lift cylinder lever

EVERY 100 HOURS

■ Checking VHT Neutral Spring

1. Park the vehicle on a flat place.
2. Set the parking brake.
3. Shift the range gear shift lever to the "NEUTRAL" position.
4. Lock the hydraulic lift cylinder lever to the "NEUTRAL" position with restricting plate.
5. Start the engine.
6. Make sure that the rotation speed of the engine returns to the idling rotation immediately when taking the foot off the pedal, after depressing the speed control pedal several times. If the above does not occur immediately, consult your local KUBOTA dealer for this service.

■ Checking VHT Pressure Release



WARNING

To avoid serious injury:

- Do not touch muffler or exhaust pipes while they are hot; severe burns could result.

1. Park the vehicle on a level surface and set the parking brake.
2. Start the engine and shut it off quickly.
3. Check the points as shown in the figures below.
4. If the result corresponds to either of the following (a) or (b), consult your local KUBOTA Dealer.
 - (a) No clearance between rod and link.
 - (b) The length of the rod is appeared 21.5 mm and over.

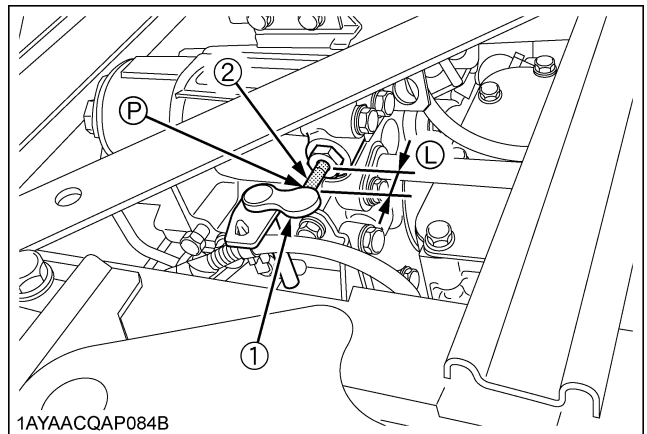

1AYAACQAP084B

(1) Unload link

(2) Unload valve rod

(L) 21.5 mm and over

(P) The link is contact with the rod.

■ Checking Wheel Fastener Torque



WARNING

To avoid serious injury:

- Never operate vehicle with a loose wheel bolts.
- Any time bolts are loosened, retighten to the specified torque.
- Check all bolts frequently and keep them tight.

Check wheel bolts regularly especially when new. If they are loose, tighten them as follows.

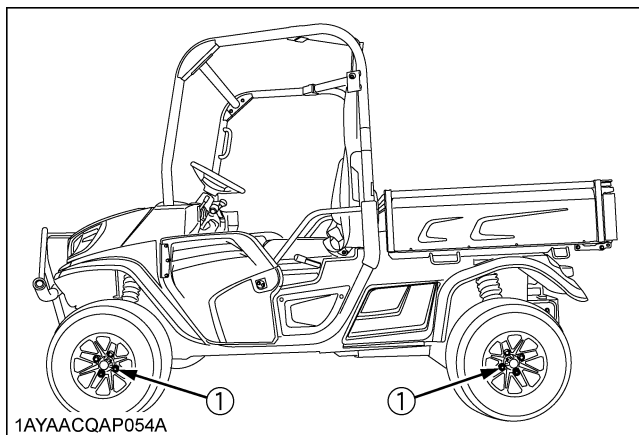

(1) Tightening torque (bolts and nuts)

Aluminum wheel: 90 to 110 N-m

(9.2 to 11.2 kgf-m) (66.4 to 81.1 lbf-ft)

Steel wheel: 108 to 130 N-m

(11.1 to 13.2 kgf-m) (79.7 to 95.8 lbf-ft)

■ Cleaning Air Cleaner Primary Element

1. Remove the air cleaner cover and primary element.
2. Clean the primary element:
 - (1) When dry dust adheres to the element, blow compressed air from the inside, turning the element. Pressure of compressed air must be under 205 kPa (2.1 kgf/cm², 30 psi).
 - (2) When carbon or oil adheres to the element, replace the element with new one even if it has not been used for 1 year.
Do not blow material onto yourself. Wear appropriate protective gear when cleaning element.
3. Replace the primary element:

Once yearly or after every sixth cleaning, whichever comes first.

NOTE :

- Check to see if the evacuator valve is blocked with dust.
- Check the rubber seal. Replace if damaged.

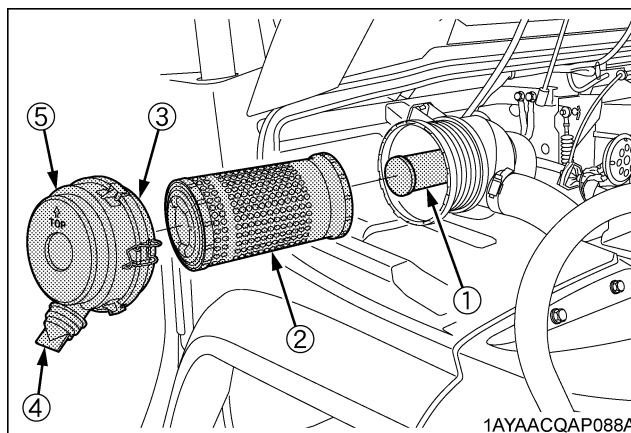

(1) Secondary (safety) element

(2) Primary element

(3) Rubber seal

(4) Evacuator valve

(5) Cover

IMPORTANT :

- The air cleaner uses a dry element, never apply oil.
- Do not run the engine with filter element removed.
- Be sure to refit the cover with the arrow (on the rear of cover) upright. If the cover is improperly fitted, evacuator valve will not function and dust will adhere to the element.
- Do not touch the secondary element except in cases where replacing is required.

◆ Evacuator Valve

Open the evacuator valve once a week under ordinary conditions - or daily when used in a dusty place - to get rid of large particles of dust and dirt.

■ Adjusting Alternator Belt Tension

WARNING

To avoid serious injury:

- Be sure to stop the engine before checking belt tension.

Proper alternator belt tension	A deflection of between 7 to 9 mm (0.28 to 0.34 in.) when the belt is pressed in the middle of the span.
--------------------------------	--

1. Park the vehicle on a flat surface, open the seat, remove utility box and maintenance cover.
2. Stop the engine.
3. Apply moderate thumb pressure to belt between pulleys.
4. If tension is incorrect, loosen the alternator mounting bolts and, using a lever placed between the alternator and the engine block, pull the alternator out until the deflection of the belt falls within acceptable limits.
5. Replace alternator belt if it is damaged.

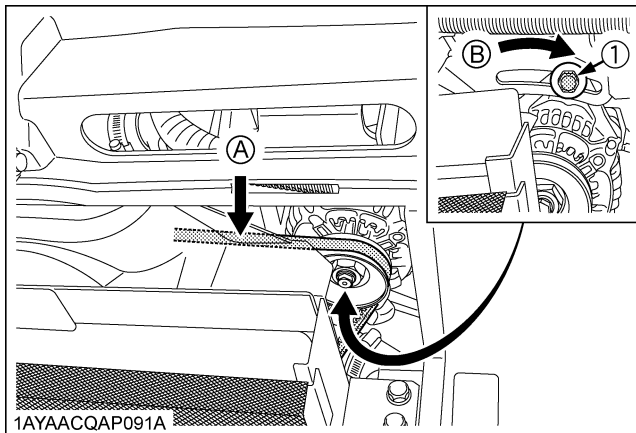

(1) Bolt

(A) Check the belt tension
(B) To tighten

■ Checking Fuel Line and Fuel Filter

WARNING

To avoid serious injury:

- Be sure to stop the engine and remove the key when attempting to make the following checks and changes.
- Never fail to check the fuel lines periodically. The fuel lines are subject to wear and aging. Fuel may leak out onto the running engine, causing a fire.

The fuel line connections should be checked annually or every 100 service hours, whichever comes first.

1. Park the vehicle on a flat surface, raise the cargo bed, mount the safety support and shut off the engine.
2. The fuel line is made of rubber and ages regardless of service period.
3. If the fuel line and clamps are found to be damaged or deteriorated, replace them.
4. Check fuel filter, if it is clogged by debris or contaminated with water, replace it.

IMPORTANT :

- When the fuel line is disconnected for maintenance or repair, close both ends of the fuel line with a piece of clean cloth or paper to prevent dust and dirt from entering. In addition, particular care must be taken not to admit dust and dirt into the fuel pump. Entrance of even a small amount of dust or dirt cause premature wear and malfunction of the fuel pump and injector components.

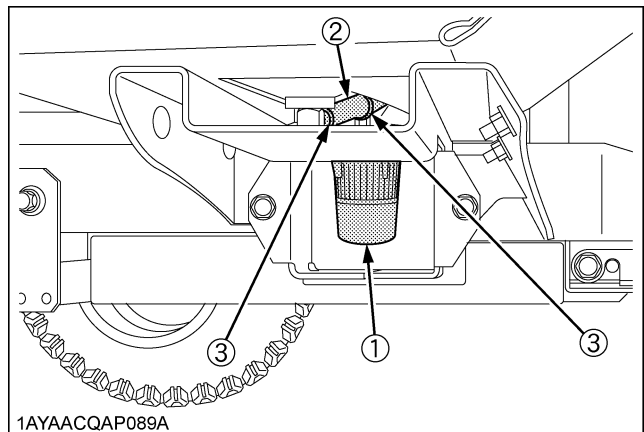

(1) Fuel filter
(2) Fuel line
(3) Pipe clamp

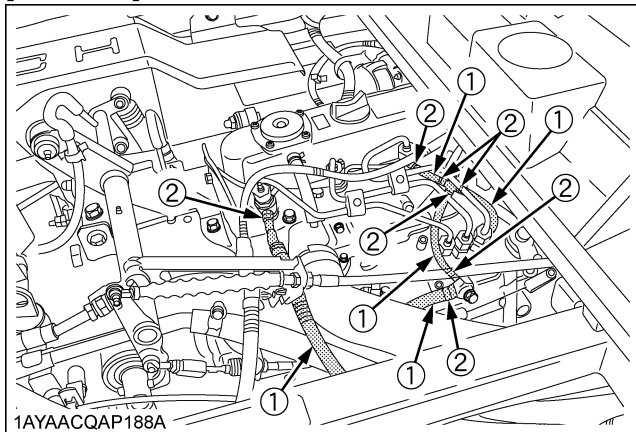
[RTV-X900]

- (1) Fuel line
(2) Pipe clamp

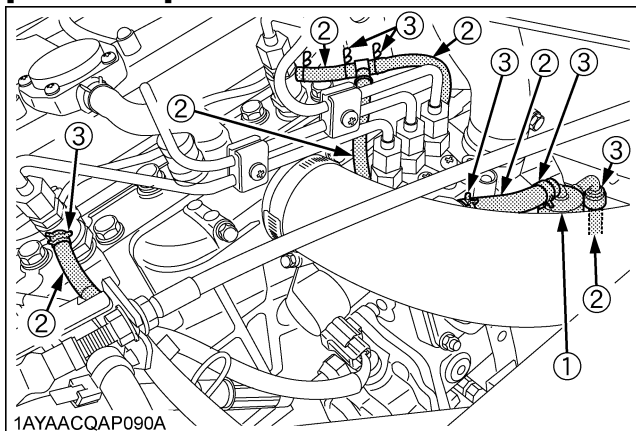
[RTV-X1120D]

- (1) Fuel pump
(2) Fuel line
(3) Pipe clamp

■ Checking Battery Condition**DANGER**

To avoid the possibility of battery explosion:
For the refillable type battery, follow the instructions below.

- Do not use or charge the refillable type battery if the fluid level is below the LOWER (lower limit level) mark. Otherwise, the battery component parts may prematurely deteriorate, which may shorten the battery's service life or cause an explosion. Check the fluid level regularly and add distilled water as required so that the fluid level is between the UPPER and LOWER levels.

**DANGER**

To avoid serious injury or death:

- When the battery is being activated, hydrogen and oxygen gases in the battery are extremely explosive. Keep open sparks and flames away from the battery at all times, especially when charging the battery.

**WARNING**

To avoid serious injury:

- Batteries, battery posts, terminals and related accessories contain lead and lead compounds, and other chemicals known to the State of California to cause cancer and birth defects or other reproductive harm. **WASH HANDS AFTER HANDLING.**
- Never remove the battery cap while the engine is running.
- Keep electrolyte away from eyes, hands and clothes. If you are splattered with it, wash it away completely with water immediately and get medical attention.
- Keep open sparks and flames away from the battery at all times. Hydrogen gas mixed with oxygen becomes very explosive.
- Wear eye protection and rubber gloves when working around battery.

The factory-installed battery is non-refillable type.
If the battery is weak, charge the battery or replace it with new one.

IMPORTANT :

- Mishandling the battery shortens the service life and adds to maintenance costs.
The original battery is maintenance free, but needs some servicing.
If the battery is weak, the engine will be difficult to start and the lights will be dim. It is important to check the battery periodically.
- When exchanging an old battery for new one, use battery of equal specification in table below.

Model	Battery Type	Volts (V)	Reserve Capacity (min)	Cold Cranking Amps	Capacity at 20 hrs (A. H.)	Normal Charging Rate (A)
RTV-X900	26R-560	12	-	560	86	8.6
RTV-X1120D	24R-670	12	140	670	115	11.5

(For non-accessible maintenance-free type batteries.)
Maintenance-free, non-accessible batteries are designed to eliminate the need to add water. Yet the volume of electrolyte above plates may eventually become depleted due to abnormal conditions such as high heat or improper regulator setting. Use a voltmeter to check the state of charge. (See reference chart below to determine if charging is necessary.)

Battery voltage	Reference state of charge
12.6	100%(Full charge)
12.4	75%
12.2	50%
12.0	25%
11.8	0%

◆ **Battery Charging**



DANGER

To avoid serious injury or death:

- When the battery is being activated, hydrogen and oxygen gases in the battery are extremely explosive. Keep open sparks and flames away from the battery at all times, especially when charging the battery.



WARNING

To avoid serious injury:

- When disconnecting the cable from the battery, start with the negative terminal first. When connecting the cable to the battery, start with the positive terminal first.
- Never check battery charge by placing a metal object across the posts.
Use a voltmeter or hydrometer.

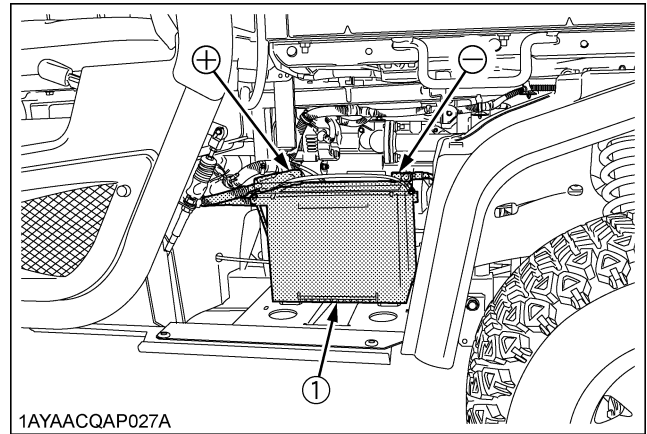

(1) Battery

1. Park the vehicle on a flat surface.
2. Stop the engine.
3. Remove the battery cover.
4. To slow charge the battery, connect the battery positive terminal to the charger positive terminal and the negative to the negative, then recharge in the standard fashion.
5. A boost charge is only for emergencies. It will partially charge the battery at a high rate and in a short time. When using a boost-charged battery, it is necessary to recharge the battery as early as possible. Failure to do this will shorten the battery's service life.
6. When exchanging an old battery for a new one, use battery of equal specification shown in table 1.

◆ **Direction for Storage**

1. When storing the vehicle for a long period, remove the battery from vehicle, adjust the electrolyte to the proper level (refillable type only) and store in a dry place out of direct sunlight.
2. The battery self-discharges while it is stored. Recharge it once every 3 months in hot seasons and once every 6 months in cold seasons.

■ Adjusting Toe-in

Proper toe-in	5 to 15 mm (0.2 to 0.59 in.)
---------------	------------------------------

1. Park vehicle on a flat place.
2. Turn steering wheel so front wheels are in the straight ahead position.
3. Lock the park brake and stop the engine.
4. Measure distance between tire beads at front of tire, at hub height.
5. Measure distance between tire beads at rear of tire, at hub height.
6. Front distance should be shorter than rear distance. If not, adjust tie rod length.

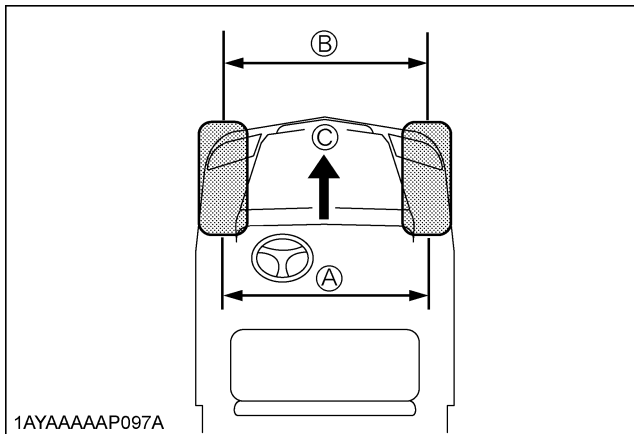

- (A) Wheel - to - wheel distance at rear
 (B) Wheel - to - wheel distance at front
 (C) "FRONT"

◆ Adjusting procedures

1. Loosen the lock nut and turn the tie rod to adjust the rod length until the proper toe-in measurement is obtained.
2. Retighten the lock nut.

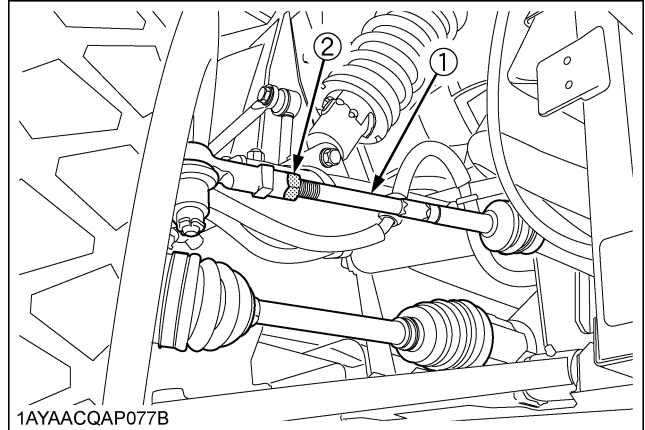

- (1) Lock nuts
 (2) Tie-rod

IMPORTANT :

- Keep the length of the left and right tie-rod equal.

NOTE :

- Tightening torque (LOCK NUT):
 74 to 84 N-m
 (7.6 to 8.5 kgf-m)
 (55 to 61 lbf-ft)

■ Cleaning Muffler

[For Swirl Type Spark Arrester]



WARNING

To avoid serious injury:

- Before touching any part of an exhaust system, be absolutely sure that it has sufficient time to cool !
- Always wear safety goggles and a (face) mask.
- The particulate matter contained in the muffler contains chemicals that are harmful to people, animals and marine life.
- If you are unable to do this work, have it done by your KUBOTA Dealer.

◆ Cleaning spark arrester of muffler

This swirl type spark arrester was examined, tested, and qualified in accordance with the USDA Forest Service Standard 5100-1c, "Spark Arresters for Internal Combustion Engines".

Maintenance & cleanout procedure:

The swirl type spark arrester should be cleaned and inspected after every 100 hours of use.

1. Set vehicle in an open area away from combustible materials and on flat surface.
2. Apply the parking brake and shift range gear shift lever into the "NEUTRAL" position.
3. Remove the drain plug located on the bottom of the muffler body.
4. Start engine and raise and lower engine revolution while tapping on the muffler with a rubber mallet until the carbon particles are purged from the muffler.
5. Stop the engine.
6. Reinstall the drain plug.

IMPORTANT :

- Visually check the muffler for cracks or holes in the body, weldment or pipes at regular intervals.
- Replace the entire muffler if it is damaged.
- Do not operate the vehicle with a damaged muffler.

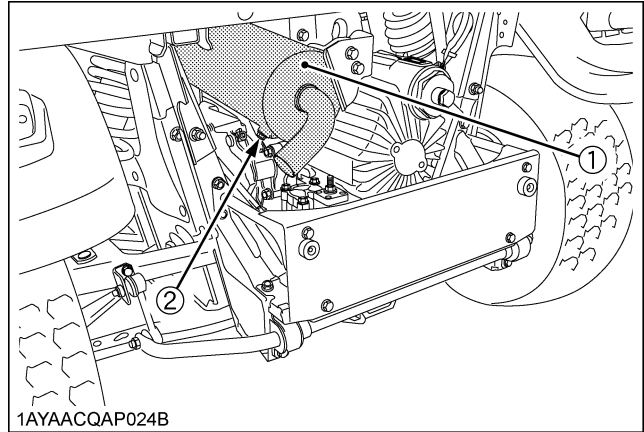

- (1) Muffler
(2) Drain plug

EVERY 200 HOURS

■ Adjusting Parking Brake

Proper parking brake lever free play range	1 notch
--	---------

◆ Adjusting procedure

1. Park the vehicle on a flat surface.
2. Stop the engine.
3. Jack up the rear wheels.
4. Remove the left rear tire.
5. Remove the mud guard of rubber.
6. Release the parking brake.
7. Loosen the lock nuts.
8. Adjust the cable wire length.
9. Tighten the lock nuts securely.
10. Install the mud guard.
11. Install the left rear tire.

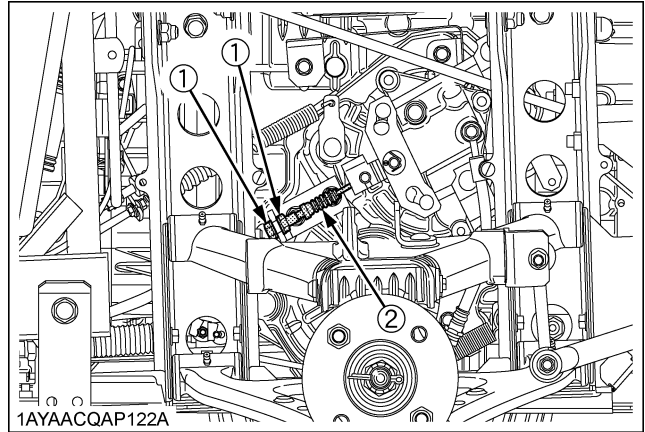

(1) Lock nut
(2) Cable wire

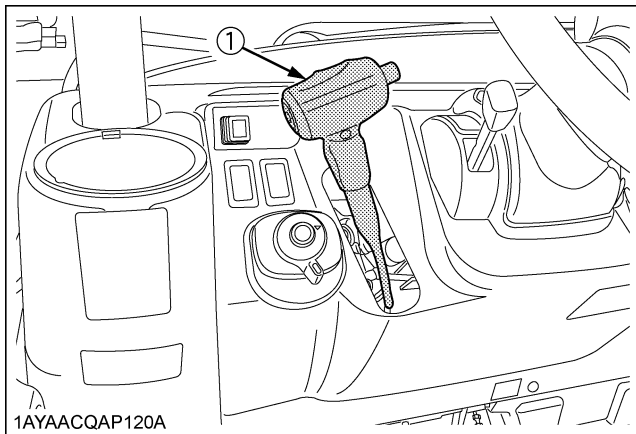

(1) Parking brake lever

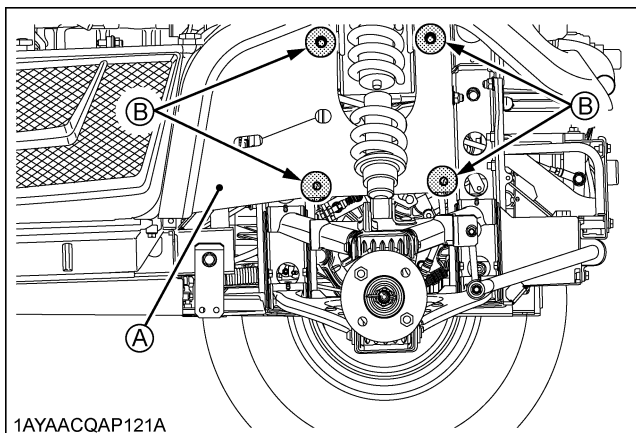

(A) Mud guard
(B) Push rivet

■ Replacing Engine Oil Filter

WARNING

To avoid serious injury:

- Be sure to stop the engine before changing the oil filter.
- Allow engine to cool down sufficiently, oil can be hot and can burn.

1. Park the vehicle on a flat surface.
2. Stop the engine.
3. Remove the rear skid plate.
4. Remove the oil filter.
5. Put a film of clean engine oil on the rubber seal of the new filter.
6. Tighten the filter quickly until it contacts the mounting surface.
Tighten the filter by hand an additional 1/2 turn only.
7. After the new filter has been replaced, the engine oil normally decreases a little. Make sure that the engine oil does not leak through the seal and be sure to check the oil level on the dipstick. Then, replenish the engine oil up to the prescribed level.
8. Properly dispose of used filter.

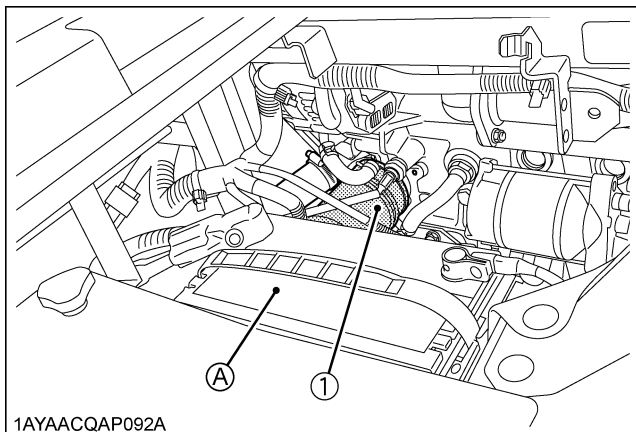

1AYAACQAP092A

(1) Engine oil filter

(A) Battery

IMPORTANT :

- To prevent serious damage to the engine, use only a KUBOTA genuine filter.

■ Changing Engine Oil

WARNING

To avoid serious injury:

- Be sure to stop the engine before changing the oil.
- Allow engine to cool down sufficiently, oil can be hot and can burn.

1. Park the vehicle on a level surface.
2. Raise the cargo bed and mount the safety support.
3. Stop the engine.
4. Remove the rear skid plate.
5. To drain the used oil, remove the drain plug at the bottom of the engine and completely drain the oil into an oil pan.
All the used oil can be drained out easily when the engine is still warm.
6. After draining, reinstall the drain plug.
7. Fill with the new prescribed oil up to the upper line on the dipstick.
(See the first table of "LUBRICANTS, FUEL AND COOLANT" in "MAINTENANCE" section.)
8. Properly dispose of used filter.

Oil capacity	RTV-X900	[Filter exchanged] 3.1 L (3.3 U.S.qts.) [Filter non-exchanged] 2.7 L (2.9 U.S.qts.)
	RTV-X1120D	[Filter exchanged] 4.1 L (4.3 U.S.qts.) [Filter non-exchanged] 3.8 L (4.0 U.S.qts.)

[RTV-X900]

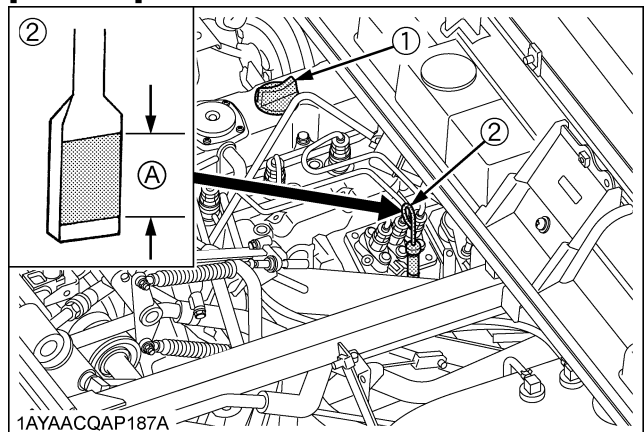

1AYAACQAP187A

(1) Oil inlet

(2) Dipstick

(A) Oil level is acceptable within this range.

[RTV-X1120D]

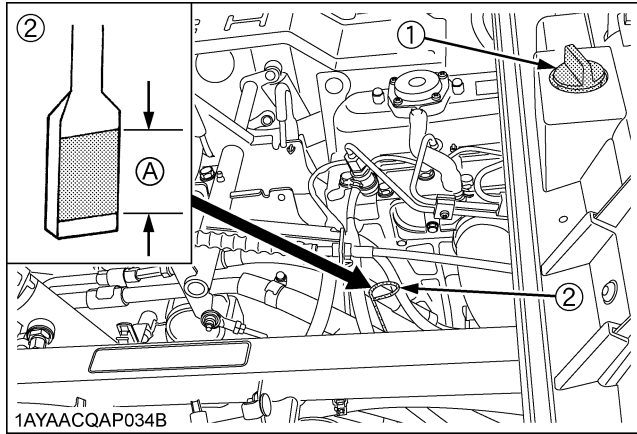

(1) Oil inlet (A) Oil level is acceptable within this range.
(2) Dipstick

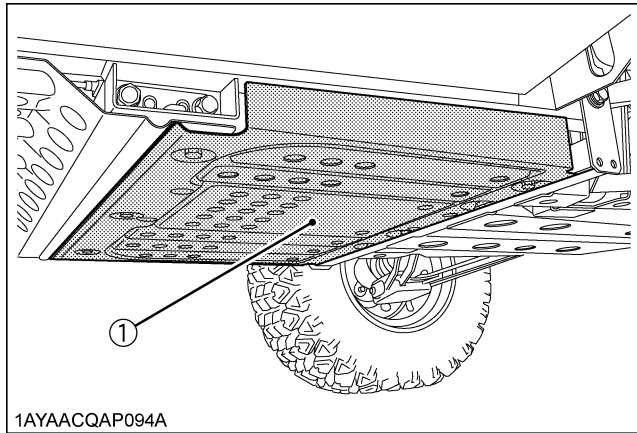

(1) Rear skid plate

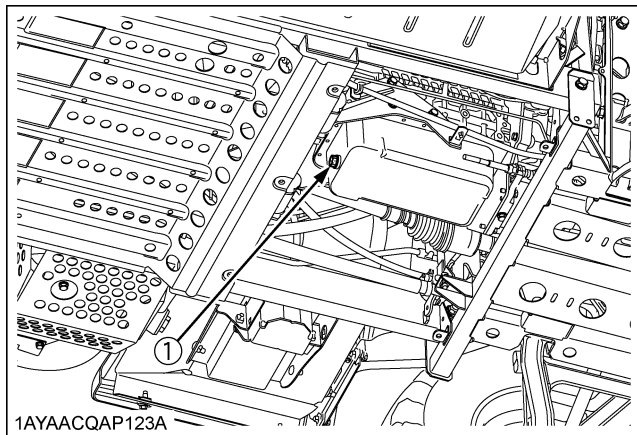

(1) Drain plug

■ Replacing Transmission Oil Filter [VHT]

WARNING

To avoid serious injury:

- Be sure to stop the engine before changing the oil filter.
- Allow engine to cool down sufficiently, oil can be hot and can burn.

1. Park the vehicle on a flat surface.
2. Remove the rear guard.
3. Remove the oil filter.
4. Put a film of clean transmission oil on the rubber seal of the new filter.
5. Quickly tighten the filter by hand until it contacts the mounting surface, then, with a filter wrench, tighten it an additional 1/2 turn only.
6. After the new filter has been replaced, fill the transmission oil up to the upper notch on the dipstick.
7. After running the engine for a few minutes, stop the engine and check the oil level again, add oil to the prescribed level.
8. Make sure that the transmission fluid doesn't leak past the seal on the filters.

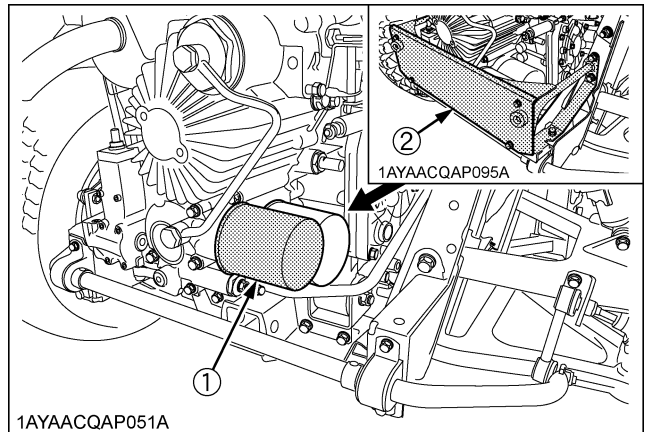

(1) Transmission oil filter (VHT) (Yellow color)
(2) Rear guard

IMPORTANT :

- To prevent serious damage to the transmission, use only a KUBOTA genuine filter.

■ Replacing Transmission Oil Filter [SUCTION]



WARNING

To avoid serious injury:

- Be sure to stop the engine before changing the oil filter.
- Allow engine to cool down sufficiently, oil can be hot and can burn.

1. Park the vehicle on a flat surface.
2. Remove the rear guard.
3. Remove the oil filter and old seal.
4. Put a film of clean transmission oil on the rubber seal of the new filter.
5. Quickly tighten the filter by hand until it contacts the mounting surface, then, with a filter wrench, tighten it an additional 1/2 turn only.
6. After the new filter has been replaced, fill the transmission oil up to the upper notch on the dipstick.
7. After running the engine for a few minutes, stop the engine and check the oil level again, add oil to the prescribed level.
8. Make sure that the transmission fluid doesn't leak past the seal on the filters.
9. Install the rear guard, and the hose guard.

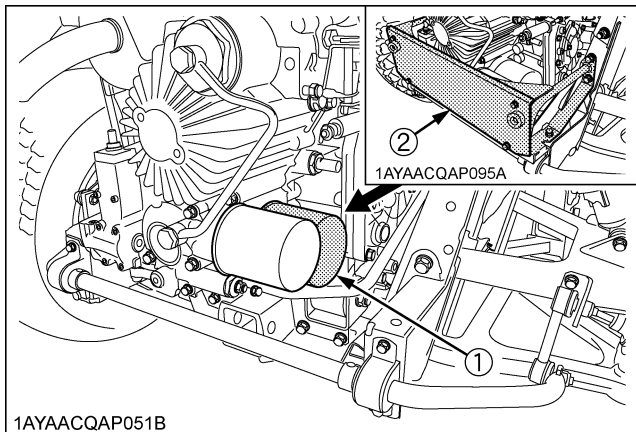

- (1) Transmission oil filter (Suction) (Black color)
(2) Rear guard

IMPORTANT :

- To prevent serious damage to the transmission, use only a KUBOTA genuine filter.

■ Changing Hydraulic Tank Oil



WARNING

To avoid serious injury:

- Be sure to stop the engine before changing the oil.
- Allow engine to cool down sufficiently, oil can be hot and can burn.

1. Park the vehicle on a level surface.
2. Open the seat and remove the utility box.
3. Remove the rubber cap.
4. To drain the used oil, remove the drain plug and filling plug and drain the oil completely into the oil pan.
5. After draining, reinstall the drain plug.
6. Fill with new prescribed oil up to the upper line on the dipstick.

(See the first table of "LUBRICANTS, FUEL AND COOLANT" in "MAINTENANCE" section.)

How to check:

Wipe dipstick clean with a rag and screw it into filling hole. Remove dipstick again to see if the oil level is between the upper and lower line.

7. After filling, reinstall the filling plug.
8. Properly dispose of used filter.

Oil Capacity	18.0 L (19.0 U.S.qts.)
--------------	------------------------

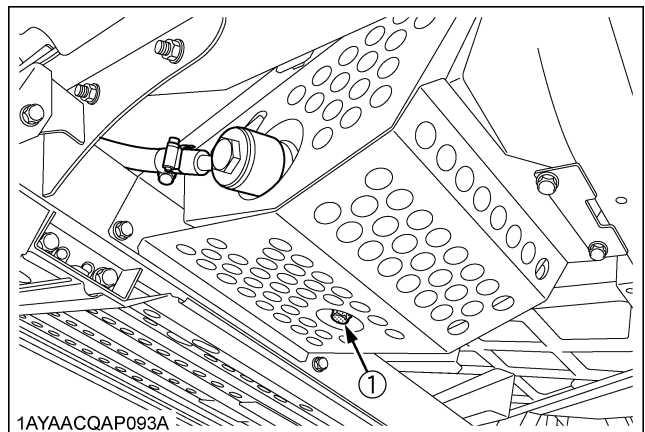

- (1) Drain plug

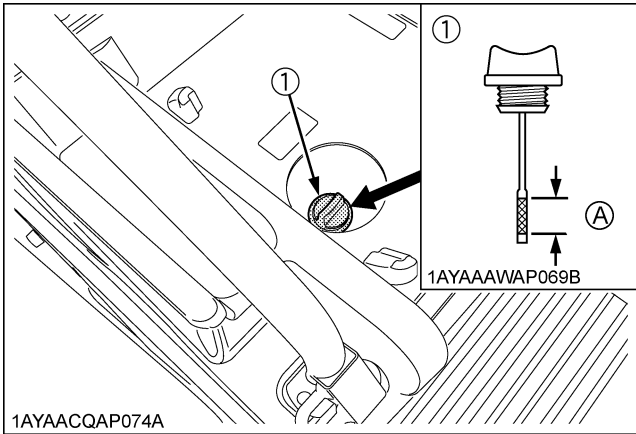

(1) Filling plug with dipstick (A) Oil level is acceptable within this range

■ Checking Brake Pedal



WARNING

To avoid serious injury:

- Stop the engine and chock the wheels before checking brake pedal.
- If movement is outside of the specifications, contact your local KUBOTA Dealer for adjusting the brake.

◆ Checking the brake pedal free travel

Proper brake pedal free travel	8 to 18 mm (0.3 to 0.7 in.) on the pedal
--------------------------------	--

1. Release the parking brake.
2. Slightly depress the brake pedal and measure free travel at the top of the pedal stroke.
3. If brake pedal free travel is outside of the specifications, contact your local KUBOTA Dealer for adjusting the brake.

◆ Checking the brake pedal stroke

Pedal stroke	Less than 150 mm (5.9 in.) on the pedal
--------------	---

1. Release the parking brake.
2. Step on the pedal and measure the pedal stroke.
3. If brake pedal stroke is outside of the specifications, contact your local KUBOTA Dealer for adjusting the brake.

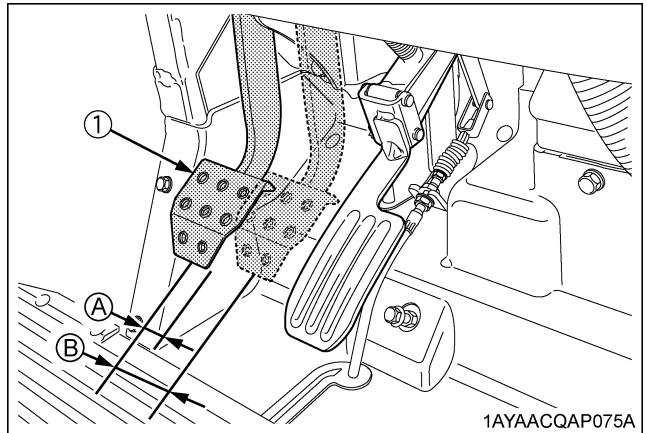

(1) Brake pedal (A) "FREE TRAVEL" (B) "PEDAL STROKE"

■ Checking Brake Hose and Pipe

1. Check to see that brake hose and pipe are not swollen, hardened or cracked.
2. Check the brake hose and pipe joints for oil leaks.
3. If there is any abnormality, consult your local KUBOTA Dealer for this service.

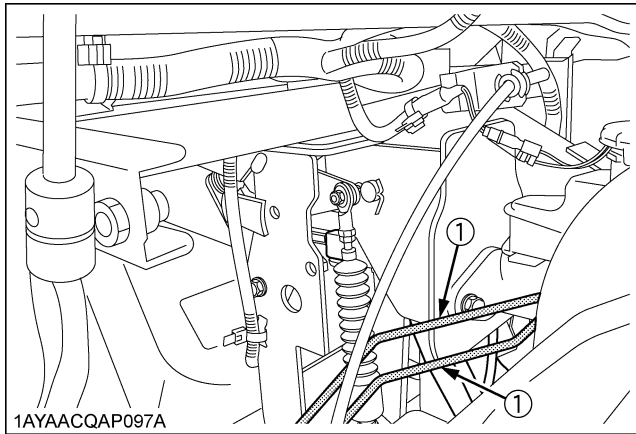

(1) Brake pipe

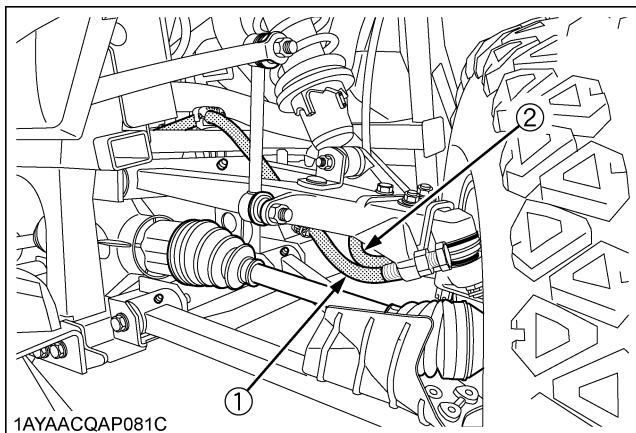

(1) Brake hose
(2) Breather hose

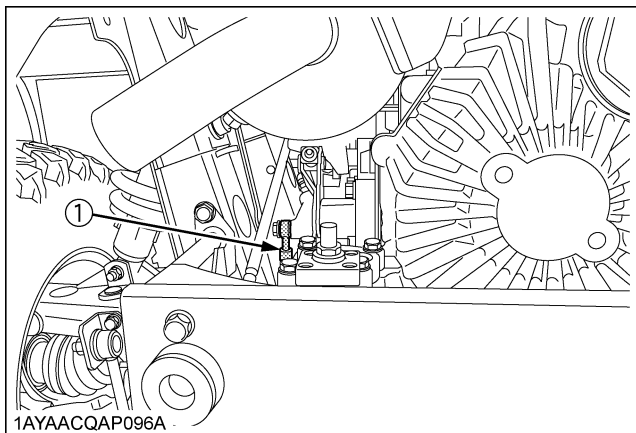

(1) Brake hose

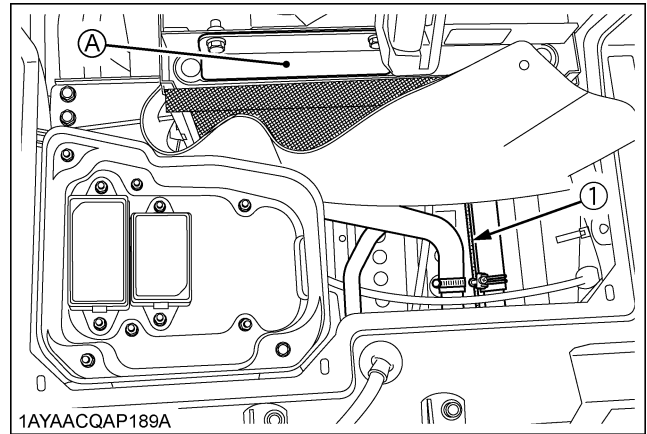

(1) Brake pipe (A) Oil cooler

■ Checking Front Brake Case

1. Remove the drain plugs and the air-bleeding hole plugs.
2. Check the brake case for brake fluid leak.
3. If there is brake fluid leak, consult your local KUBOTA Dealer for this service.

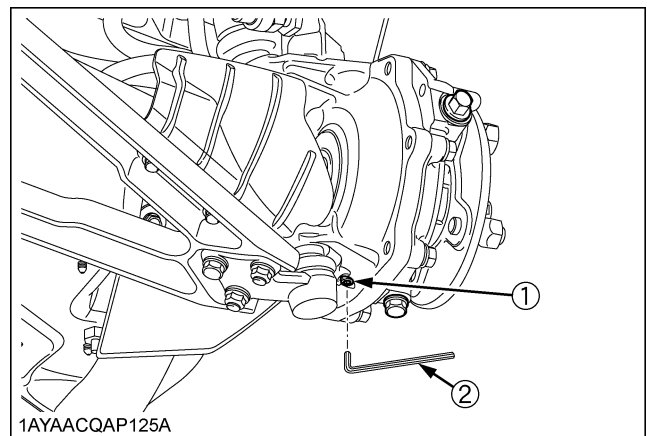
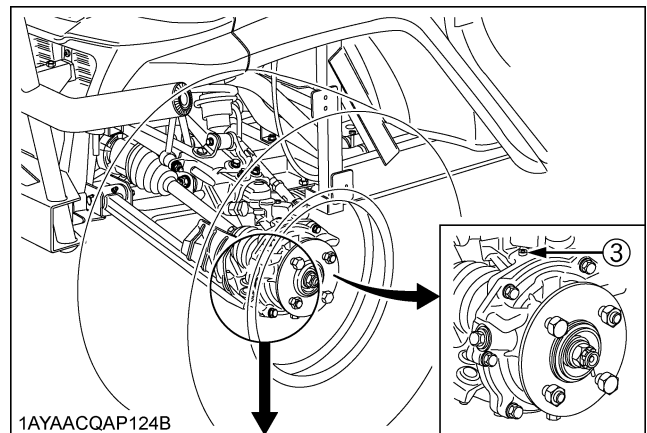

(1) Drain plug
(2) Allen key
(3) Air-bleeding hole plug

■ Checking Brake Light Switch

1. Park the vehicle on a flat surface.
2. Step on the brake pedal to check if the brake light comes on.
3. If it does not, check the bulb or brake light switch.

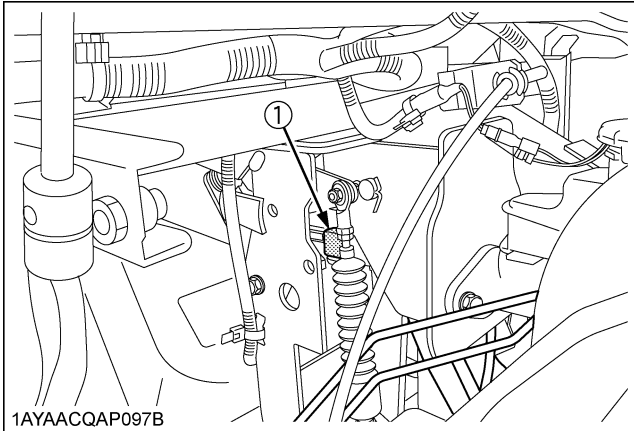

(1) Brake light switch

■ Checking Radiator Hose, Pipe and Clamp

Park the vehicle on a flat surface. Raise the cargo bed and mount the safety support.

Check to see if radiator hoses are properly fixed every 200 hours of operation or 6 months, whichever comes first.

1. If hose clamps are loose or water leaks, tighten bands securely.
2. Replace hoses and tighten hose clamps securely, if radiator hoses are swollen, hardened or cracked.

Replace hoses and hose clamps every 2 years or earlier if checked and found that hoses are swollen, hardened or cracked.

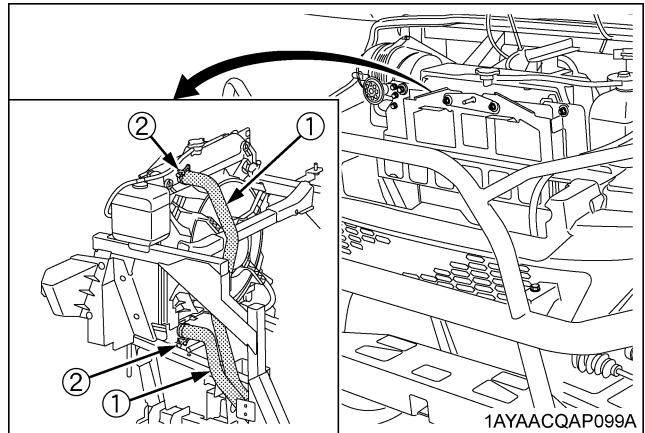

(1) Radiator hose
(2) Clamp band

[RTV-X1120D]

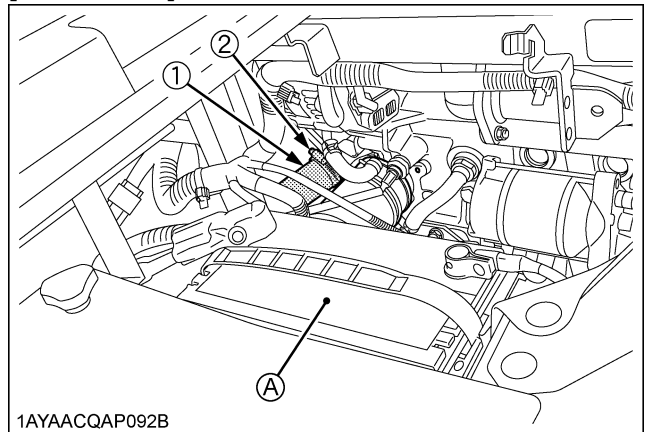

(1) Radiator hose
(2) Clamp band
(A) Battery

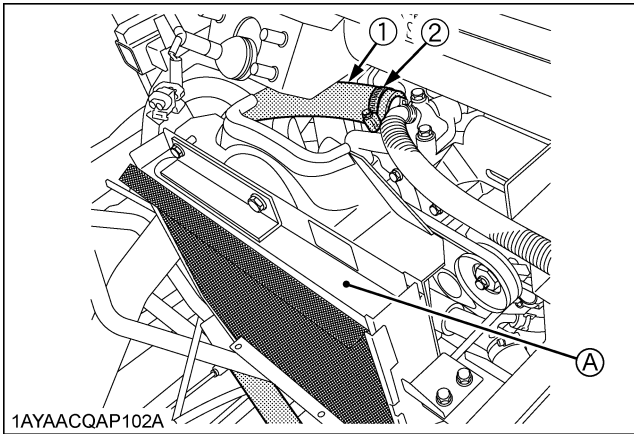

(1) Radiator hose (A) Oil cooler
(2) Clamp band

[RTV-X900]

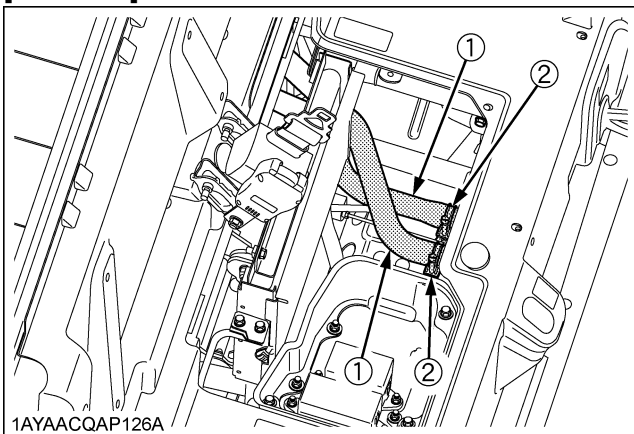

(1) Radiator hose
(2) Clamp band

[RTV-X1120D]

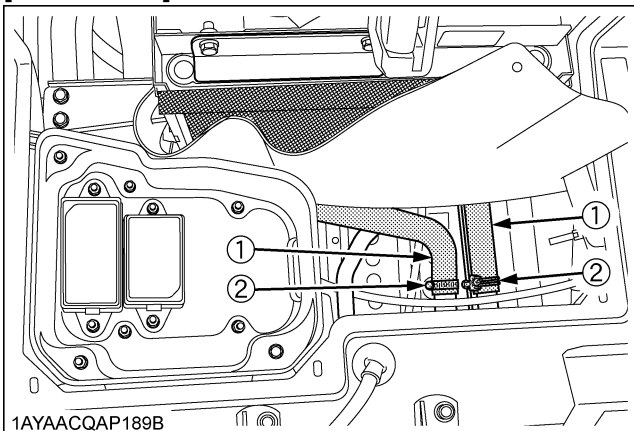

(1) Radiator hose
(2) Clamp band

◆ Precaution at Overheating

Take the following actions in the event the coolant temperature is close to or more than the boiling point, which is called "Overheating".

1. Stop the vehicle operation in a safe place, unload the engine and remain at idle.
2. Don't stop the engine suddenly, but stop it after about 5 minutes of unloaded idling.
3. Keep yourself well away from the vehicle for at least 10 minutes or while the steam is blowing out.
4. Check to confirm that there is no danger from the overheat condition, check the "TROUBLESHOOTING" section to determine the cause of the overheat and fix the cause. After the engine has cooled, re-start the engine.

■ Checking Intake Air Line

1. Check to see if the hoses and hose clamps are tight and not damaged.
2. If hoses and clamps are found to be worn or damaged, replace or repair them at once.

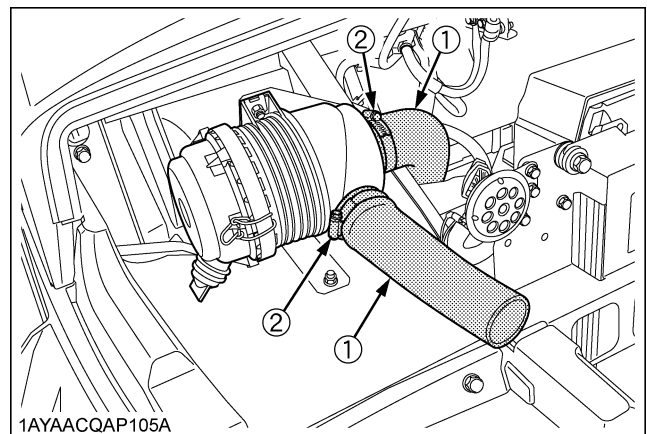

(1) Hose
(2) Hose clamp

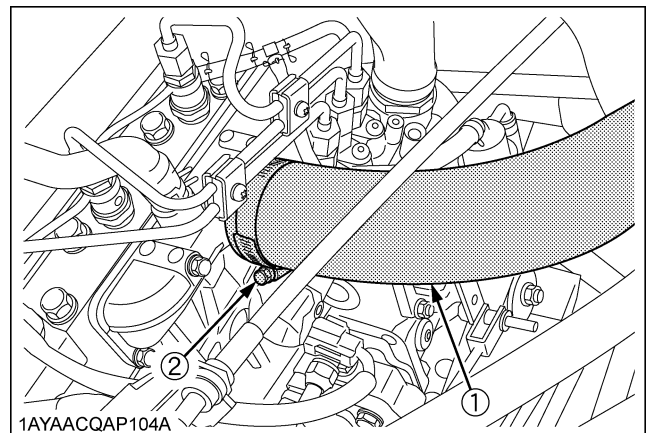

(1) Hose
(2) Hose clamp

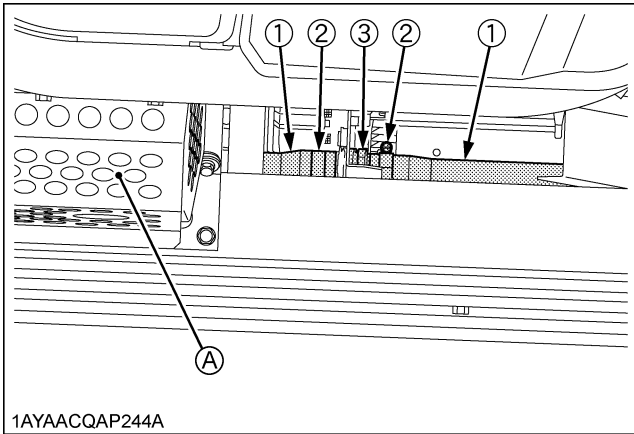

- (1) Hose
- (2) Hose clamp
- (3) Joint
- (A) Hydraulic tank

■ Checking Hydraulic Oil Line

1. Check to see if the hoses and hose clamps are tight and not damaged.
2. If hoses and clamps are found to be worn or damaged, replace or repair them at once.

[Only with hydraulic dump]

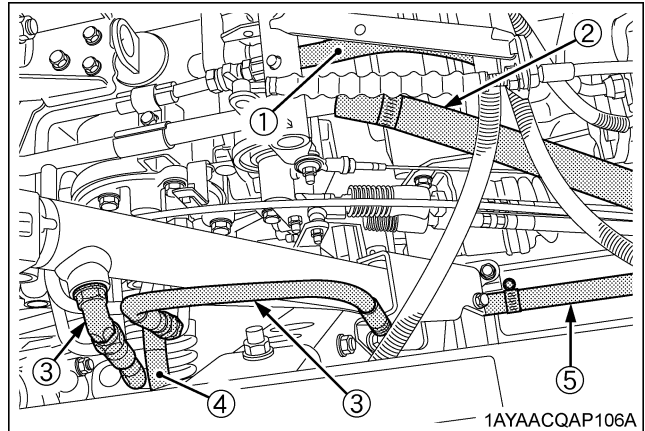

- (1) Hydraulic pump → Control valve
- (2) HST → Oil tank
- (3) Control valve ↔ Lift cylinder
- (4) Control valve → Power steering unit
- (5) Oil tank → HST

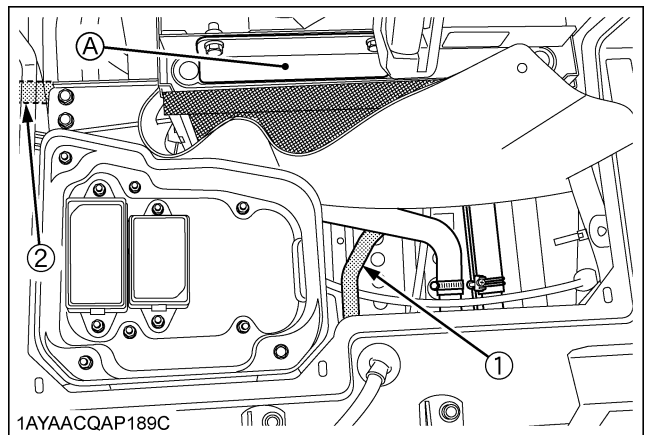

- (1) Power steering unit → Oil cooler
- (2) Oil cooler → Oil tank
- (A) Oil cooler

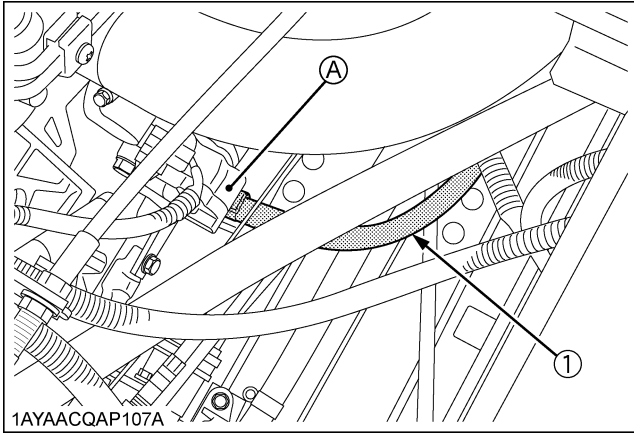

(1) Oil tank → Hydraulic pump (A) Hydraulic pump

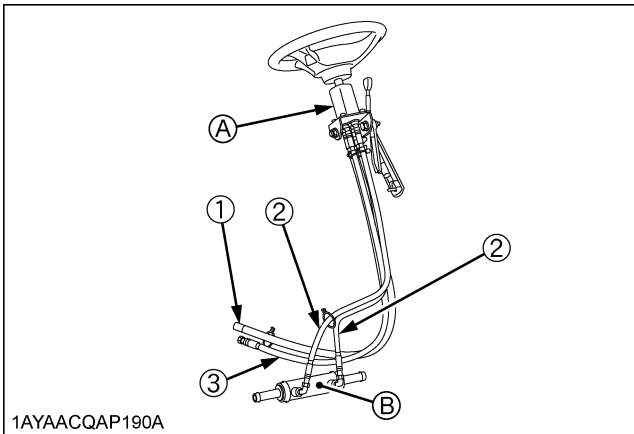

(1) Power steering hose
 (Power steering unit → Oil cooler)
 (2) Power steering hose
 (Power steering unit ↔ Power steering cylinder)
 (3) Power steering hose
 (with hydraulic dump: Power steering unit ← Control valve,
 without hydraulic dump: Power steering unit ← Hydraulic pump)
 (A) Power steering unit
 (B) Power steering cylinder

EVERY 300 HOURS

■ Checking Tire

1. Check to see if tires are not damaged.
2. If the tires are cracked, bulged, or cut, or they are worn out, replace or repair them at once.

◆ Tire Tread Depth

Always replace the tires when the tread depth is worn to minimum allowable.

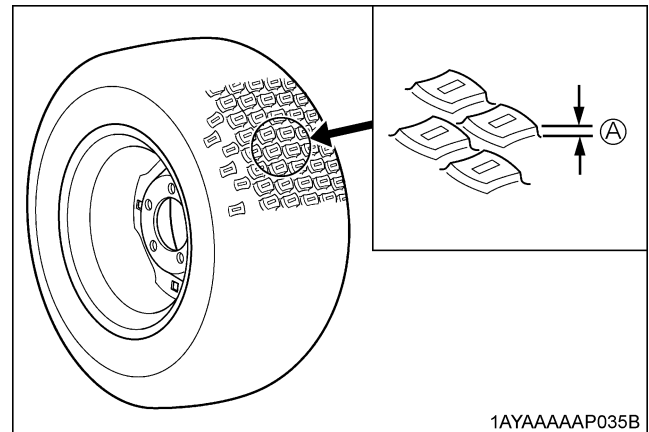

(A) 3 mm (0.12 in.)

EVERY 400 HOURS

■ Changing Front Knuckle Case Oil

1. Park the vehicle on a firm, flat and level surface.
2. Remove the tire.
3. To drain the used oil, remove the drain and filling plugs at the left hand knuckle case and drain the oil completely into the oil pan.
4. After draining, reinstall the drain plug.
5. Fill with the new prescribed oil up to the filling port level.
(See the first table of "LUBRICANTS, FUEL AND COOLANT" in "MAINTENANCE" section.)
6. After filling, reinstall the filling plug.
7. Use the same procedure to change the right hand knuckle case oil.

Oil capacity (one side)	Ref. 0.25 L (0.26 U.S.qts.)
-------------------------	-----------------------------

8. Properly dispose of used oil.

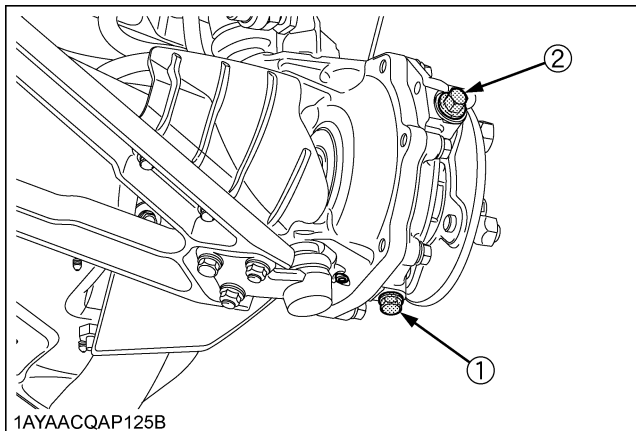
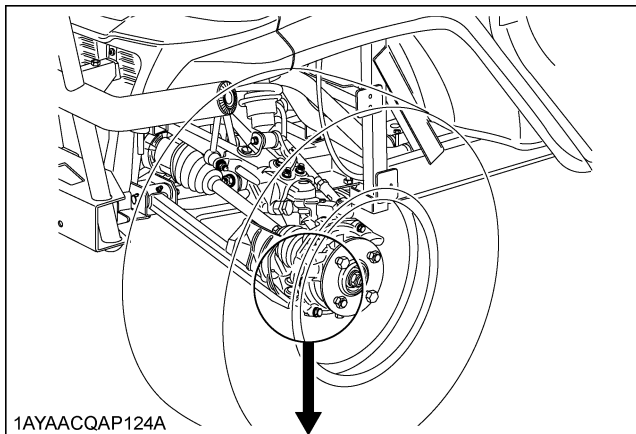

- (1) Drain plug
(2) Filling plug

■ Changing Transmission Fluid



WARNING

To avoid serious injury:

- Be sure to stop the engine before changing the oil.
- Allow engine to cool down sufficiently, oil can be hot and can burn.

1. Park the vehicle on a level surface.
2. Raise the cargo bed and mount the safety support.
3. To drain the used oil, remove the drain plug at the bottom of the transmission case and drain the oil completely into the oil pan.
4. After draining, reinstall the drain plug.
5. Fill with the new prescribed oil up to the upper cross hatched area on the dipstick.
(See the first table of "LUBRICANTS, FUEL AND COOLANT" in "MAINTENANCE" section.)
6. After running the engine for a few minutes, stop the engine and check the oil level again; add oil to prescribed level.

Oil Capacity	7.0 L (1.8 U.S.gals.)
--------------	-----------------------

7. Properly dispose of used oil.

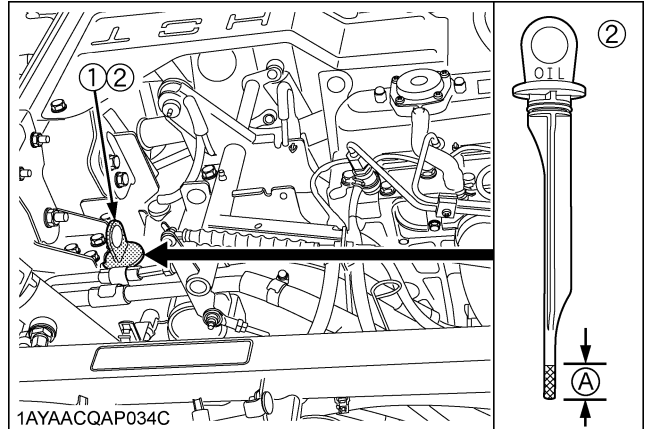

- (1) Oil inlet (A) Oil level is acceptable within this range.
(2) Dipstick

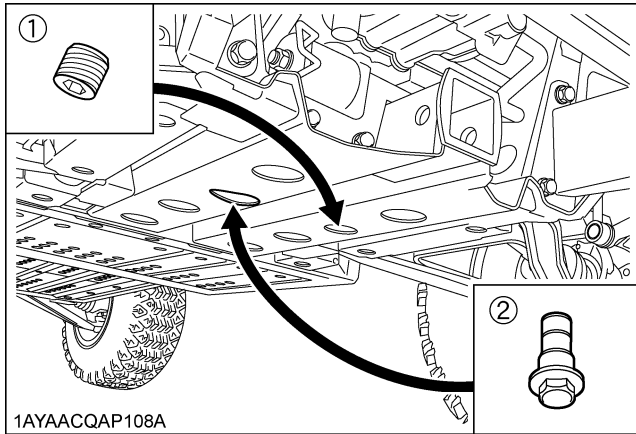

(1) Drain plug
(2) Magnet plug

◆ **Cleaning Magnet Plug**

Remove the magnet plug and clean off metal filings.

IMPORTANT :

- Do not operate the vehicle immediately after changing the transmission fluid.
Run the engine at medium speed for a few minutes to prevent damage to the transmission.

■ **Changing Front Axle Case Oil**

1. Park the vehicle on a level surface.
2. Turn over the rubber sheet.
3. To drain the used oil, remove the drain plug and the filling plug at the front axle case and drain the oil completely into the oil pan.
4. After draining, reinstall the drain plug.
5. Fill with the new prescribed oil up to the upper line on the dipstick.
(See the first table of "LUBRICANTS, FUEL AND COOLANT" in "MAINTENANCE" section.)
6. After filling, reinstall the filling plug.
7. Properly dispose of used oil.

Oil capacity	0.6 L (0.6 U.S.qts.)
--------------	----------------------

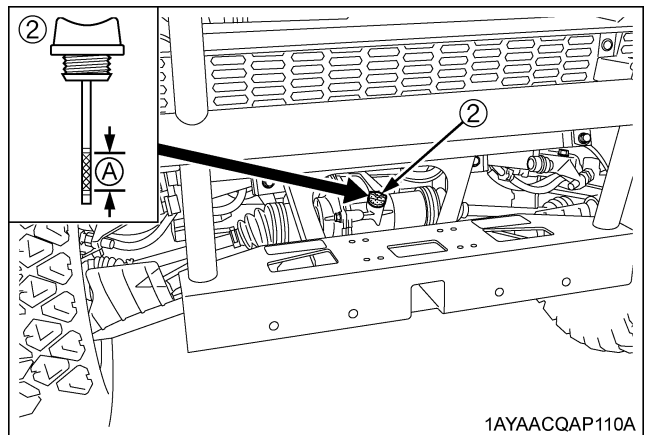
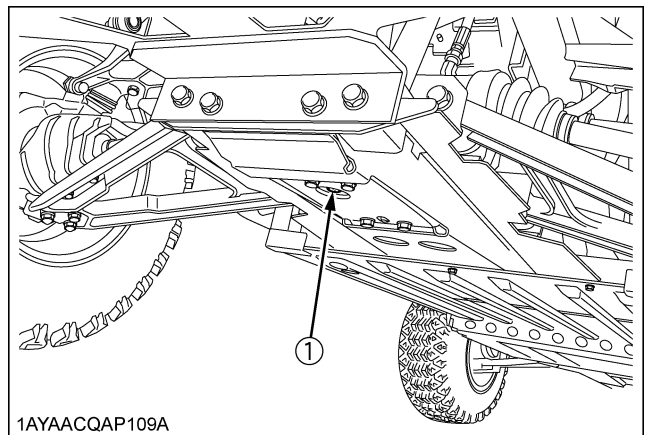

(1) Drain plug
(2) Filling plug with dipstick

(A) Oil level is acceptable within this range

EVERY 500 HOURS**■ Replacing Fuel Filter**

Consult your local KUBOTA Dealer for this service.

EVERY 800 HOURS**■ Adjusting Engine Valve Clearance**

Consult your local KUBOTA Dealer for this service.

EVERY 1500 HOURS**■ Checking Fuel Injection Nozzle Injection Pressure**

Consult your local KUBOTA Dealer for this service.

EVERY 3000 HOURS**■ Checking Injection Pump**

Consult your local KUBOTA Dealer for this service.

EVERY 1 YEAR**■ Replacing Air Cleaner Primary Element and Secondary Element**

(See "Cleaning Air Cleaner Primary Element" in "EVERY 100 HOURS" in "PERIODIC SERVICE" section.)

EVERY 2 YEARS**■ Changing Brake Fluid**

Consult your local KUBOTA Dealer for this service.
(See "Checking Brake Fluid Level" in "DAILY CHECK" in "PERIODIC SERVICE" section.)

■ Flushing Cooling System and Changing Coolant**WARNING**

To avoid serious injury:

- Do not remove the radiator cap while coolant is hot. When cool, slowly rotate cap to the first stop and allow sufficient time for excess pressure to escape before removing the cap completely.

1. Stop the engine and let cool down.
2. Open the hood.
3. To drain the coolant, open the radiator drain plug and remove radiator cap and engine coolant breather. The radiator cap must be removed to completely drain the coolant.
4. After all coolant is drained, close the drain plug.
5. Fill with clean water and cooling system cleaner.
6. Follow directions of the cleaner instruction.
7. After flushing, fill with clean distilled water and anti-freeze until the coolant level is just below the radiator cap.
Install the radiator cap securely.
8. Fill with fresh distilled water up to the "FULL" mark on the recovery tank.
9. Close the engine coolant breather.
10. Start and operate the engine for few minutes.
11. Stop the engine and let cool.
12. Check coolant level of recovery tank and add coolant if necessary.

Coolant capacity	6.1 L (6.4 U.S.qts.)
------------------	----------------------

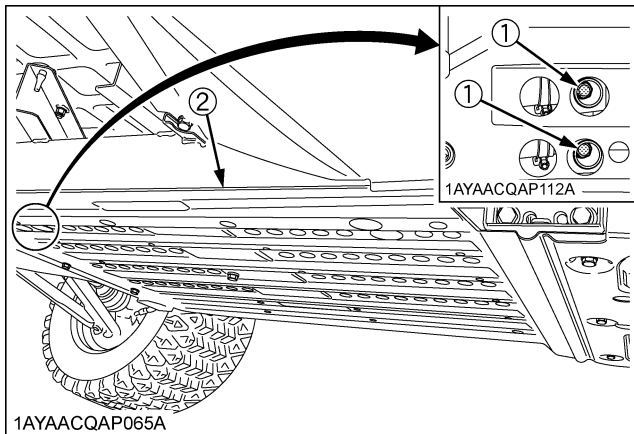

(1) Drain plug
(2) Front skid plate

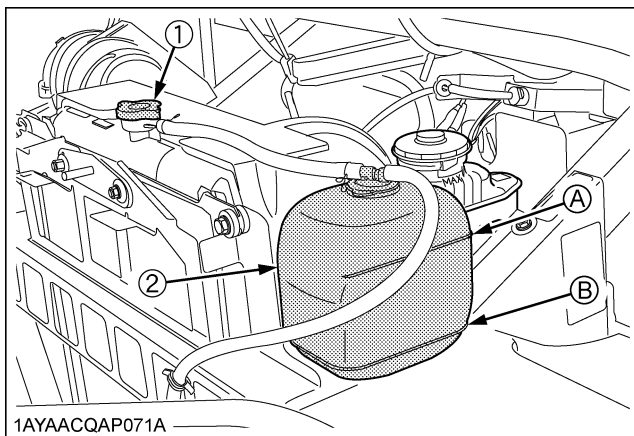

(1) Radiator cap
(2) Recovery tank
(A) "FULL"
(B) "LOW"

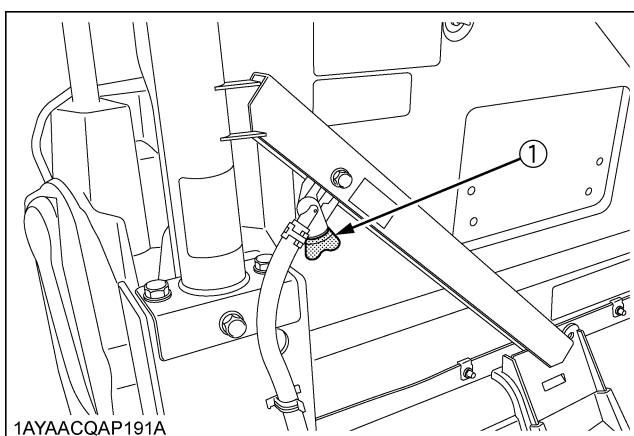

(1) Engine coolant breather

IMPORTANT :

- Do not start engine without coolant.
- Do not remove the cap on the radiator.
- Use clean, fresh distilled water and anti-freeze to fill the radiator and recovery tank.

- When the anti-freeze is mixed with distilled water, the anti-freeze mixing ratio is 50%.
- Securely tighten radiator cap. If the cap is loose or improperly fitted, water may leak out and the engine could overheat.
- Make sure that the engine coolant breather is closed, after filling the coolant.

Anti-Freeze

! WARNING

To avoid serious injury:

- When using anti-freeze, put on some protection such as rubber gloves. (Anti-freeze contains poison.)
- If it is swallowed, seek immediate medical help. Do NOT make a person throw up unless told to do so by poison control or a health care professional. Use standard first aid and CPR for signs of shock or cardiac arrest. Call your local Poison Control Center or your local emergency number for further assistance.
- When anti-freeze comes in contact with the skin or clothing, wash it off immediately.
- Do not mix different types of Anti-freeze. The mixture can produce chemical reaction causing harmful substances.
- Anti-freeze is extremely flammable and explosive under certain conditions. Keep fire and children away from anti-freeze.
- When draining fluids from the engine, place some container underneath the engine body.
- Do not pour waste onto the ground, down a drain, or into any water source.
- Also, observe the relevant environmental protection regulations when disposing of anti-freeze.

Always use a 50/50 mix of long-life coolant and clean soft water in KUBOTA engines.

Consult your local KUBOTA dealer concerning coolant for extreme conditions.

1. Long-life coolant (hereafter LLC) comes in several types. Use ethylene glycol (EG) type for this engine.
2. Before employing LLC-mixed cooling water, fill the radiator with fresh water and empty it again. Repeat this procedure 2 or 3 times to clean up the inside.
3. Mixing the LLC
Premix 50% LLC with 50% clean soft water. When mixing, stir it up well, and then fill into the radiator.
4. The procedure for the mixing of water and anti-freeze differs according to the make of the anti-freeze and the ambient temperature. Refer to SAE J1034 standard, more specifically also to SAE J814c.

IMPORTANT :

- When mixing the anti-freeze with water, the anti-freeze mixing ratio is 50%.

Vol % Anti-freeze	Freezing Point		Boiling Point*	
	°C	°F	°C	°F
50	-37	-34	108	226

* At 1.013 x 10⁵Pa (760 mmHg) pressure (atmospheric).

A higher boiling point is obtained by using a radiator pressure cap which permits the development of pressure within the cooling system.

5. Adding the LLC

- (1) Add only water if the coolant level reduces in the cooling system by evaporation.
- (2) If there is a mixture leak, add the LLC of the same manufacturer and type in the mixing ratio 50%.

* Never add any long-life coolant of different manufacturer. (Different brands may have different additive components, and the engine may fail to perform as specified.)

6. When the LLC is mixed, do not employ any radiator cleaning agent. The LLC contains anti-corrosive agent. If mixed with the cleaning agent, sludge may build up, adversely affecting the engine parts.
7. Kubota's genuine long-life coolant has a service life of 2 years. Be sure to change the coolant every 2 years.

NOTE :

- The above data represent industry standards that necessitate a minimum glycol content in the concentrated anti-freeze.

■ Replacing Radiator Hose (Water pipes)

Replace the hoses and clamps.

(See "Checking Radiator Hose, Pipe and Clamp" in "EVERY 200 HOURS" in "PERIODIC SERVICE" section.)

■ Replacing Hydraulic Oil Line

Consult your local KUBOTA Dealer for this service.

■ Replacing Fuel Hose

Consult your local KUBOTA Dealer for this service.

■ Replacing Engine Breather Hose

Consult your local KUBOTA Dealer for this service.

■ Replacing Brake Master Cylinder (Inner Parts)

Consult your local KUBOTA Dealer for this service.

■ Replacing Front Brake Seal

Consult your local KUBOTA Dealer for this service.

■ Replacing Rear Brake Cylinder Seal

Consult your local KUBOTA Dealer for this service.

■ Replacing Intake Air Line

Consult your local KUBOTA Dealer for this service.

(See "Checking Intake Air Line" in every 200 hours maintenance.)

■ Replacing Air Conditioner Pipe and Hose

Consult your local KUBOTA Dealer for this service.

EVERY 4 YEARS

■ Replacing Brake Hose

Consult your local KUBOTA Dealer for this service.

SERVICE AS REQUIRED

■ Bleeding Fuel System

Air must be removed:

1. When the fuel filter or lines are removed.
2. When tank is completely empty.
3. After the vehicle has not been used for a long period of time.

◆ Bleeding procedure is as follows:

1. Fill the fuel tank with fuel.
2. Pump the fuel pump lever. The fuel pump lever will pump easily at first and with added resistance as air is purged from the system.

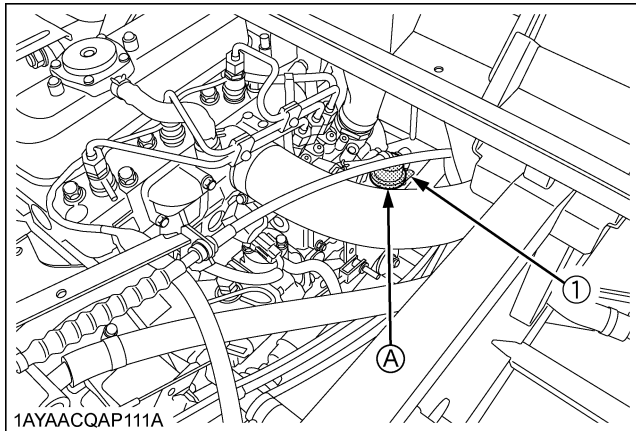

(1) Fuel pump lever (A) Fuel pump

3. Start the engine and run for about 30 seconds, and then stop the engine.

■ Cleaning around Engine

(See "Checking around Engine" in "DAILY CHECK" in "PERIODIC SERVICE" section.)

■ Replacing Fuse

The vehicle electrical system is protected from potential damage by fuses.

A blown fuse indicates that there is an overload or short somewhere in the electrical system.

If any of the fuses should blow, replace with a new one of the same capacity.

IMPORTANT :

- Before replacing a blown fuse, determine why the fuse blew and make any necessary repairs. Failure to follow this procedure may result in serious damage to the vehicle electrical system. Consult your local KUBOTA Dealer for specific information dealing with electrical problems.

◆ Replacement procedure

1. Disconnect the negative cable of the battery.
2. Open the seats and remove the utility box and maintenance cover.
3. Remove the fuse box cover.
4. Pull out the blown fuse using FUSE PULLER in the fuse box.
5. Insert a new fuse into the fuse box.
6. Install the fuse box cover and the maintenance cover.
7. Connect the negative battery cable.

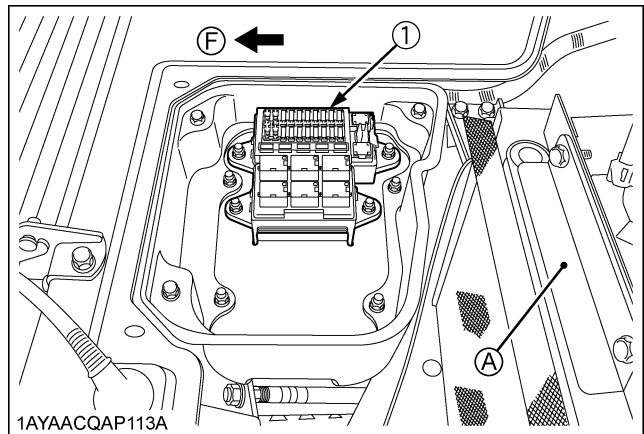

(1) Fuse box (A) Oil cooler (F) Front

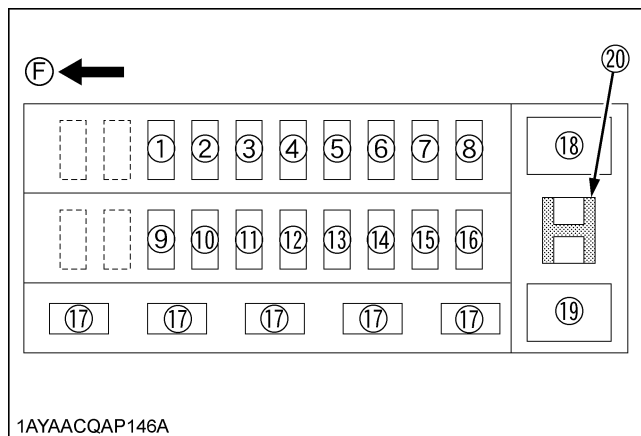

(F) Front

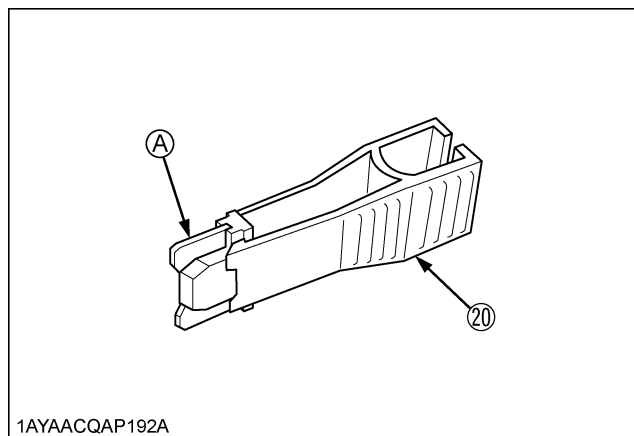

(20) Fuse puller

(A) Fuse

[RTV-X900]

Protected circuit

Fuse No.	Capacity (A)	Protected circuit
1	5	Glow lamp
2	5	Starter relay
3	10	Radiator fan relay
4	10	AUX / B, Buzzer relay (OPT, LAMP)
5	5	Key stop timer
6	5	Meter (IGN)
7	15	Beacon / Fog lamp
8	15	Head light blinker (F)
9	15	Blinker (R) brake lamp
10	30	Radiator fan
11	10	DC output
12	20	---
13	10	Horn
14	15	Work light
15	15	Key stop timer
16	5	Meter (BAT)
17	30, 20, 15, 10, 5	Spare
18	Slow-blow fuse (60)	Key switch
19	Slow-blow fuse (60)	Alternator
20	-	Fuse puller

[RTV-X1120D]

Protected circuit

Fuse No.	Capacity (A)	Protected circuit
1	5	Glow lamp
2	5	Starter relay
3	10	Radiator fan relay
4	10	AUX / B, Buzzer relay (OPT, LAMP)
5	5	Solenoid
6	5	Meter (IGN)
7	15	Beacon / Fog lamp
8	15	Head light blinker (F)
9	15	Blinker (R) brake lamp
10	30	Radiator fan
11	10	DC output
12	20	---
13	10	Horn
14	15	Work light
15	30	Solenoid
16	5	Meter (BAT)
17	30, 20, 15, 10, 5	Spare
18	Slow-blow fuse (60)	Key switch
19	Slow-blow fuse (60)	Alternator
20	-	Fuse puller

■ Replacing Slow-Blow Fuses

The slow-blow fuses are intended to protect the electrical cabling. If any of them have blown out, be sure to pinpoint the cause. Never use any substitute, use only a KUBOTA genuine part.

◆ Replacement procedure

1. Disconnect the negative cable of the battery.
2. Open the seats and remove the utility box and maintenance cover.
3. Remove the fuse box cover.
4. Pull out the slow-blow fuse.
5. Insert a new slow-blow fuse into the slow-blow fuse box.
6. Install the slow-blow fuse box cover and the maintenance cover.
7. Connect the negative battery cable.

■ Replacing Light Bulb

1. Head light and turn signal light (front)
Take the bulb out of the light body and replace it with a new one.
2. Other lights
Detach the lens and replace the bulb.

Light	Capacity
Head light (Clear type)	37.5 W
Tail light	5 W
Brake light	21 W
Turn signal light (front)	21 W (if equipped)
Turn signal light (rear)	21 W (if equipped)
Work light (front)	35 W (if equipped)
Work light (rear)	27 W (if equipped)

■ Checking Hydraulic Tank Suction Strainer

1. Make sure that the hydraulic tank is not damaged and the oil does not leak out of the hydraulic tank.
2. Make sure that the water is not mixed with the oil.
3. When the suction strainer is dirty, wash it with the light oil.

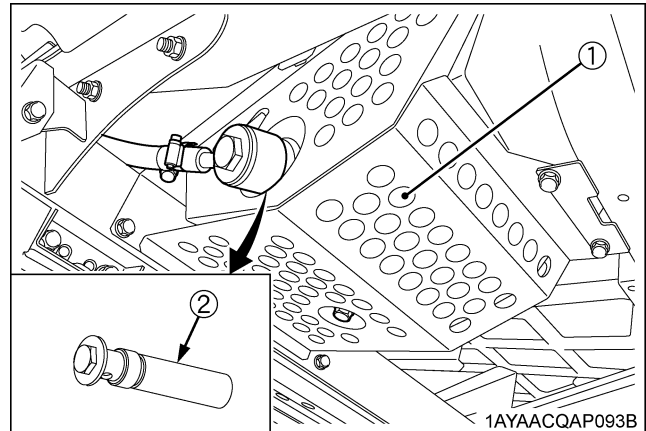

(1) Hydraulic tank
(2) Suction strainer

STORAGE



WARNING

To avoid serious injury:

- Do not clean the vehicle with engine running.
- To avoid the danger of exhaust fume poisoning, do not operate the engine in a closed building without proper ventilation.
- When storing, remove the key from the ignition switch to avoid unauthorized persons from operating the vehicle and getting injured.

VEHICLE STORAGE

If you intend to store your vehicle for an extended period of time, follow the procedures outlined below.

These procedures will insure that the vehicle is ready to operate with minimum preparation when it is removed from storage.

1. Check the bolts and nuts for looseness, and tighten if necessary.
2. Apply grease to vehicle areas where bare metal will rust also to pivot areas.
3. Unload the cargo bed.
4. Inflate the tires to a pressure a little higher than usual.
5. Change the engine oil and run the engine to circulate oil throughout the engine block and internal moving parts for about 5 minutes.
6. With all implements lowered to the ground, coat any exposed hydraulic cylinder piston rods with grease.
7. Remove the battery from the vehicle. Store the battery following the battery storage procedures.
(See "Checking Battery Condition" in "EVERY 100 HOURS" in "PERIODIC SERVICE" section.)
8. Keep the vehicle in a dry place where the vehicle is sheltered from the elements. Cover the vehicle.
9. Store the vehicle indoors in a dry area that is protected from sunlight and excessive heat. If the vehicle must be stored outdoors, cover it with a waterproof tarpaulin.
Put boards under the tires to keep dampness away from tire.
Keep the tires out of direct sunlight and extreme heat.

IMPORTANT :

- When washing the vehicle, be sure to stop the engine. Allow sufficient time for the engine to cool before washing.
- Do not wash with a high-pressure car-washing machine.
- Cover the vehicle after the muffler and the engine have cooled down.

REMOVING THE VEHICLE FROM STORAGE

1. Check the tire air pressure and inflate the tires if they are low.
2. Install the battery. Before installing the battery, be sure it is fully charged.
3. Check the alternator belt tension.
4. Check all fluid levels (engine oil, transmission oil, hydraulic oil, brake fluid, engine coolant and any attached implements).
5. Start the engine. Observe all gauges. If all gauges are functioning properly and reading normal, move the vehicle outside. Once outside, park the vehicle and let the engine idle for at least 5 minutes. Shut the engine off and walk around vehicle and make a visual inspection looking for evidence of oil or water leaks.
6. With the engine fully warmed up, release the parking brake and test the brakes for proper adjustment as you move forward. Adjust the brakes as necessary.

TROUBLESHOOTING

ENGINE TROUBLESHOOTING

If something is wrong with the engine, refer to the table below for the cause and its corrective measure.

Trouble		Cause	Countermeasure
Engine is difficult to start or won't start.		<ul style="list-style-type: none"> No fuel flow. 	<ul style="list-style-type: none"> Check the fuel tank and the fuel filter. Replace filter if necessary.
		<ul style="list-style-type: none"> Air or water is in the fuel system. 	<ul style="list-style-type: none"> Check to see if the fuel line coupler bolt and nut are tight. Bleed the fuel system. (See "Bleeding Fuel System" in "SERVICE AS REQUIRED" in "PERIODIC SERVICE" section.)
		<ul style="list-style-type: none"> In winter, oil viscosity increases, and engine revolution is slow. 	<ul style="list-style-type: none"> Use oils of different viscosities, depending on ambient temperatures.
		<ul style="list-style-type: none"> Battery becomes weak and the engine does not turn over quick enough. 	<ul style="list-style-type: none"> Clean battery cables and terminals. Charge the battery. In cold weather, always remove the battery from the engine, charge and store it indoors. Install it on the vehicle only when the vehicle is going to be used.
Insufficient engine power.		<ul style="list-style-type: none"> Insufficient or dirty fuel. The air cleaner is clogged. 	<ul style="list-style-type: none"> Check the fuel system. Clean or replace the element.
Engine stops suddenly.		<ul style="list-style-type: none"> Insufficient fuel. 	<ul style="list-style-type: none"> Refuel. Bleed the fuel system if necessary.
Exhaust fumes are colored.	Black	<ul style="list-style-type: none"> Fuel quality is poor. Too much oil. The air cleaner is clogged. 	<ul style="list-style-type: none"> Change the fuel and fuel filter. Check the proper amount of oil. Clean or replace the element.
	Blue white	<ul style="list-style-type: none"> The inside of exhaust muffler is dumped with fuel. Injection nozzle trouble. Fuel quality is poor. 	<ul style="list-style-type: none"> Heat the muffler by applying load to the engine. Check the injection nozzle. Change the fuel and fuel filter.
Engine overheats		<ul style="list-style-type: none"> Engine overloaded. 	<ul style="list-style-type: none"> Shift to lower gear or reduce load.
		<ul style="list-style-type: none"> Low coolant level. 	<ul style="list-style-type: none"> Fill cooling system to the correct level; check radiator and hoses for loose connections or leaks.
		<ul style="list-style-type: none"> Dirty radiator core or grille screens. 	<ul style="list-style-type: none"> Remove all trash.
		<ul style="list-style-type: none"> Coolant flow route corroded. 	<ul style="list-style-type: none"> Flush cooling system.

If you have any questions, contact your local KUBOTA Dealer.

BATTERY TROUBLESHOOTING

Trouble	Cause	Countermeasure	Preventive measure
Starter does not function.	● Battery overused until lights are dim.	● Charge battery sufficiently.	● Charge the battery properly.
	● Battery has not been recharged.		
	● Poor terminal connection.	● Clean the terminal and tighten securely.	● Keep the terminal clean and tight. Apply grease and treat with anti-corrosives.
	● Battery life expired.	● Renew battery.	
From beginning starter does not function, and lights soon become dim.	● Insufficient charging.	● Charge battery sufficiently.	● Battery must be serviced properly before initial use.
When viewed from top, the top of plates look whitish. * Refillable type battery only	● Battery was used with an insufficient amount of electrolyte.	● Add distilled water and charge the battery.	● Regularly check the electrolyte level.
	● Battery was used too much without recharging.	● Charge battery sufficiently.	● Charge the battery properly.
Recharging is impossible.	● Battery life expired.	● Replace battery.	
Terminals are severely corroded and heat up.	● Poor terminal connection.	● Clean the terminal and tighten securely.	● Keep the terminal clean and tight. Apply grease and treat with anti-corrosives.
Battery electrolyte level drops rapidly. * Refillable type battery only	● There is a crack or pin holes in the electrolytic cells.	● Replace battery.	
	● Charging system trouble.	● Consult your local KUBOTA Dealer.	

- If you have any questions, consult your local KUBOTA Dealer.
- The factory-installed battery is non-refillable type.

MACHINE TROUBLESHOOTING

Trouble	Cause	Countermeasure
Machine operation is not smooth.	● Hydrostatic transmission fluid is insufficient.	● Replenish oil.
	● Filter is clogged.	● Replace the filter.
Machine does not move while engine is running.	● Parking brake is on.	● Release the parking brake.
	● Transmission fluid level is insufficient.	● Replenish oil.
Brakes not working correctly	● Brake fluid level is low.	● Check fluid level.
	● Air is in brake system.	● Consult your KUBOTA Dealer.
	● Brake pads are worn.	● Consult your KUBOTA Dealer.
Brake noise	---	● Consult your KUBOTA Dealer.
HST oil overheats	● HST overloaded.	● Reduce load.
	● Low oil level.	● Fill oil to the correct level.
	● Dirty oil cooler core or screens.	● Remove all trash.
	● Oil flow route corroded.	● Check oil cooling system.
	● Hydraulic lever is positioned at the end of stroke.	● Set the lever to the "NEUTRAL" ("OFF") position.

If you have any questions, consult your local KUBOTA Dealer.

OPTIONS

Consult your local KUBOTA Dealer for further details.

- Backup Beeper
- Bed Liner
- Fabric Cover
- Front Mud Guard
- Front Trailer Hitch & Pin
- Front Work Light
- Rear Trailer Hitch & Pin
- Rear Work Light
- Front Blade (72")
- Strobe Light (Beacon)
- Tail Lamp Guards
- Turn Signal / Hazard Light Kit
- Winch Kit

INDEX

12V Electric Outlet.....	25	Front End.....	50
4WD Lever.....	21	Front Knuckle Case Oil.....	78
Air Cleaner Primary Element.....	62	Front Trailer Hitch.....	40
Air Cleaner Primary Element and Secondary Element.....	80	Fuel Filter.....	80
Air Conditioner Pipe and Hose.....	82	Fuel Gauge.....	23
Alternator Belt Tension.....	63	Fuel Hose.....	82
Anti-Freeze.....	81	Fuel Injection Nozzle Injection Pressure.....	80
Around Engine.....	51	Fuel Line and Fuel Filter.....	63
Around Engine.....	83	Fuel System.....	83
Backup Beeper.....	58	Fuse.....	83
Battery Condition.....	64	General Caution.....	31
Block Heater.....	13	Glove Box (Std.) and Glove Box Cover (if equipped).....	26
Brake Fluid.....	80	Greasing.....	59
Brake Fluid Level.....	55	Hazard Light Switch.....	18
Brake Hose.....	83	Head Light Switch.....	18
Brake Hose and Pipe.....	73	Head Light, Turn Signal Light (if equipped) etc.....	56
Brake Light Switch.....	74	Hills.....	29
Brake Master Cylinder (Inner Parts).....	82	Hood.....	49
Brake Pedal.....	20	Horn Button.....	19
Brake Pedal.....	56	Hourmeter and Odometer.....	24
Brake Pedal.....	72	Hydraulic Oil Line.....	76
Cargo Bed Tailgate.....	33	Hydraulic Oil Line.....	82
Checking and Refueling.....	52	Hydraulic Oil Tank Level.....	53
Cold Weather Starting.....	13	Hydraulic Outlet Lever.....	36
Coolant Level.....	54	Hydraulic Outlet Valve Coupler Connecting and Disconnecting.....	37
Coolant Temperature Gauge.....	23	Hydraulic Tank Oil.....	71
Differential Lock.....	26	Hydraulic Tank Suction Strainer.....	85
Directions for Use of Power Steering.....	27	Immediately Stop the Engine if:	22
Do not Operate the Vehicle at Full Speed for the First 50 Hours.....	16	Inflation Pressure.....	38
Driving in "4WD".....	28	Injection Pump.....	80
Driving in Reverse.....	27	Intake Air Line.....	75
Driving through Water.....	30	Intake Air Line.....	82
Easy Checker(TM).....	22	Joint Boot.....	57
Easy Checker(TM).....	56	Light Bulb.....	85
Engine Breather Hose.....	82	Locking and Unlocking the Door.....	16
Engine Hand Throttle.....	13	Lubricating Oil for New Vehicles.....	16
Engine Oil.....	69	Max. Cargo Load.....	31
Engine Oil Filter.....	69	Muffler.....	67
Engine Oil Level.....	52	Oil Cooler Net.....	55
Engine Start System.....	60	Parking Brake.....	56
Engine Valve Clearance.....	80	Parking Brake.....	68
Flushing Cooling System and Changing Coolant.....	80	Parking Brake Lever.....	21
Front Axle Case Oil.....	79	Parking Brake Lever.....	25
Front Brake Case.....	73	Radiator Hose (Water pipes).....	82
Front Brake Seal.....	82	Radiator Hose, Pipe and Clamp.....	74

Radiator Screen	54
Raising and Lowering the Cargo Bed.....	33
Raising and Lowering the Cargo Bed [if equipped with hydraulic dump]	50
Raising and Lowering the Cargo Bed [without hydraulic dump].....	35
Raising and Lowering the Cargo Bed [without hydraulic dump].....	50
Range Gear Shift Lever.....	20
Rear Brake Cylinder Seal.....	82
Rear End	51
Rear Trailer Hitch	40
Seat.....	49
Seat Belt.....	17
Seat Belt and ROPS.....	56
Seat Slide Lever	17
Shock Absorber Spring Adjustment	39
Sliding and Skidding.....	29
Slow-Blow Fuses.....	85
Speed Control Pedal	22
Speedometer.....	24
Stopping	22
Tilt Steering Wheel.....	17
Tire	77
Tire Inflation Pressure	58
Tire Type and Use.....	38
Toe-in	66
Transmission Fluid	78
Transmission Fluid Level.....	53
Transmission Oil Filter [SUCTION]	71
Transmission Oil Filter [VHT]	70
Transport the Vehicle Safely	41
Traversing Hillsides	29
Turn Signal Light Switch.....	18
Turning the Vehicle	28
Unfamiliar Terrain.....	27
Utility Box	25
VHT Neutral Spring	61
VHT Pressure Release.....	61
Walk Around Inspection	51
Warm-Up Transmission Oil in the Low Temperature Range	14
Wheel Fastener Torque.....	62
Winch Mount Bracket	41
Work Light (Front)	19
Work Light (Rear).....	19